



**CONTROL DATA®
FLEXIBLE DISK DRIVE
MODEL 9404-B**

**GENERAL DESCRIPTION
OPERATION
INSTALLATION AND CHECKOUT
THEORY OF OPERATION
DIAGRAMS
MAINTENANCE
WIRE LISTS
PARTS DATA**

MAGNETIC PERIPHERALS INC.

 a subsidiary of
CONTROL DATA CORPORATION



PREFACE

This Special Equipment Documentation publication when used with the Control Data Corporation Model 9404B Hardware Maintenance Manual 75897465, will support the following special configurations of the Model 9404 FDD

<u>TOP MECHANICAL</u>	<u>EQUIPMENT NO.</u>	<u>PRINTED WIRING ASSEMBLY NO.</u>
75744064	BR8A5J	77636248
75744064	BR8A5J	77636249
75744064	BR8A5J	77636200
75744082	BR8A5H	77643200

The data contained in this Special Equipment Documentation is unique to the above configurations. Section and paragraph designations are keyed to those of the basic Model 9404B Hardware Maintenance Manual for ease of reference and use.

A configurator sheet is provided on the following page which describes each FDD configuration that this publication will support. Refer to the equipment name-plate located on the right hand side of the unit (as viewed from the front) to determine the appropriate Top Mechanical Assembly (TMA) and Model numbers. Then use the Configurator sheet as a starting point to establish the maintenance level for the device.

FLEXIBLE DISK DRIVE CONFIGURATOR SHEET

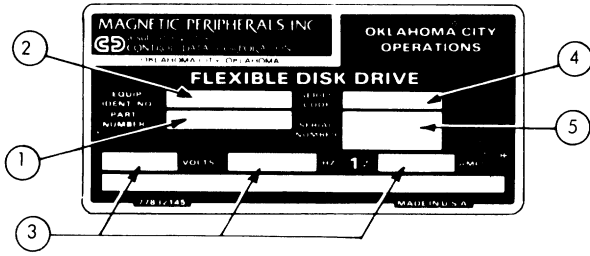

- ① TOP MECHANICAL ASSEMBLY NO. (TMA)
- ② MODEL NO. (BR8XXX)
- ③ AC POWER REQUIRED.
- ④ EQUIPMENT STATUS NUMBER
- ⑤ UNIT SERIAL NO.

P O W E R R E Q U I R E D	V D C	+5 & +24 AT J7									
		+5 & +24 AT J10									
	V A C	120, 1Ø									
WRITE PROTECT											
DAISY-CHAIN INTERFACE											
TMA NO.		TYPE NO.		PWA NO.							
75744064		BR8A5J		77636200		X	X	X			X
75744064		BR8A5J		77636248		X	X	X			X
75744064		BR8A5J		77636249		X	X	X			X
75744082		BR8A5H		77643200		X	X	X		X	X

Z280

TABLE OF CONTENTS

SECTION	PAGE
GENERAL DESCRIPTION	
1.1 INTRODUCTION	1-1
1.2 PURPOSE AND USE OF EQUIPMENT	1-1
1.3 PRODUCT DESCRIPTION	1-1
1.3.1 Physical Description	1-2
1.3.2 Electrical Description	1-2
1.3.3 Performance Characteristics	1-2
OPERATION	
2.1 INTRODUCTION	2-1
2.2 OPERATING INSTRUCTIONS	2-1
2.2.1 Flexible Diskette Loading	2-1
2.2.2 Flexible Diskette Removal	2-1
2.3 ERROR RECOVERY	2-1
2.3.1 Seek Error	2-1
2.3.2 Write Error	2-1
2.3.3 Read Error	2-2
2.4 DISKETTE HANDLING RECOMMENDATIONS	2-2
INSTALLATION AND CHECKOUT	
3.1 INTRODUCTION	3-1
3.2 UNPACKING	3-1
3.3 INSTALLATION	3-1
3.4 CABLING AND CONNECTIONS	3-1
3.4.1 INPUT-OUTPUT CABLE	1**
3.4.2 DC POWER CONNECTION	1**
3.4.3 AC POWER CONNECTION	3-2
3.5 ENVIRONMENT	3-2
3.6 INITIAL CHECKOUT	3-2
THEORY OF OPERATION	
4.1 INTRODUCTION	4-1
4.2 GENERAL DESCRIPTION	4-1
4.3 FUNCTIONAL DESCRIPTION	4-3
4.3.1 Control Logic	4-3
4.3.2 Write Logic	4-5
4.3.3 Read Logic	4-5
4.3.4 Disk Drive	4-6
4.3.5 Read/Write Head	4-6
4.4 CONTROL AND DATA LINE CHARACTERISTICS	4-6
4.4.1 Logic Levels	4-6
4.4.2 Transmitter Characteristics	4-6
4.4.3 Line Receiver Characteristics	4-6
4.4.4 Control and Data Line Functions	4-6

**Page Numbers refer to 75897464, all others refer to 75897465.

SECTION PAGE

DIAGRAMS AND MAINTENANCE AIDS

5.1	DIAGRAMS	5-1
5.2	MAINTENANCE AIDS	5-1
5.2.1	Introduction	5-1
5.2.2	Physical Description (Logic)	5-1
5.2.3	Use of Relative Level Indicators	5-1
5.2.4	Integrated Circuits	5-1

MAINTENANCE

6.1	INTRODUCTION	6-1
6.2	MAINTENANCE TOOLS	6-1
6.3	PREVENTIVE MAINTENANCE	6-1
6.4	HEAD CLEANING	6-1
6.5	TROUBLESHOOTING	6-2
6.5.1	DC Voltage and Signal	6-2
6.6	ADJUSTMENT PROCEDURES	6-4
6.6.1	Carriage-Stop Adjustment	6-4
6.6.2	Burst To Index Check and Adjustment	6-4
6.6.3	Actuator Alignment (Diskette)	6-7
6.6.4	Push-Rod Travel Adjustment	6-8
6.6.5	Door-Interlock Switch Adjustment	6-9
6.6.6	Disk-Load Bail Adjustment	6-10
6.6.7	Spindle and Cone Adjustment	6-11
6.6.8	Write Protect Assembly Adjustment (Where Applicable) ...	14**
6.6.9	Track '00' Switch Adjustment	6-12
6.7	REMOVAL AND REPLACEMENT PROCEDURES	6-12
6.7.1	Printed Circuit Board (PWA)	14**
6.7.2	Actuator Assembly	6-13
6.7.3	Drive-Motor Assembly	6-15
6.7.4	Head-Load-Pad Replacement	6-15
6.7.5	Solenoid Replacement and Tang Adjustment	6-15
6.7.6	Carriage and/or Stepper Motor Replacement	6-17

WIRE LISTS

7.1	INTRODUCTION	7-1
7.2	UPPER HARNESS ASSEMBLIES	7-1
7.3	LOWER HARNESS ASSEMBLY	7-1
7.4	STEPPER MOTOR	7-1
7.5	WRITE PROTECT	7-1

**Page Numbers refer to 75897464, all others refer to 75897465.

SECTION

PAGE*

PARTS DATA

8.1	INTRODUCTION	8-1
8.2	ILLUSTRATIONS	8-1
8.3	PARTS LISTS	8-1
8.4	TOP MECHANICAL AND ASSEMBLY LOCATION	8-1
	8.4.1 Top Mechanical Assembly (TMA)	8-1
8.5	REPLACEMENT PARTS	8-1
8.6	PARTS LIST INSTRUCTIONS	8-11
	8.6.1 Illustration Parts Lists	8-11
	8.6.2 Top-Down Assembly/Component Parts Lists	8-11
	8.6.3 Cross Reference Index	8-11
	8.6.4 Sheet Number Referencing	8-11

*Page Numbers refer to Section 8 9404B Manual.

LIST OF ILLUSTRATIONS

FIGURE NO.	TITLE	PAGE
2-1	Diskette Installation	2-2
4-1	Functional Block Diagram	4-2
5-1	Timing	5-2
5-2	Schematic (Tab 64)	3**
5-3a	Assembly (Tab 64)	9**
5-3b	Assembly (Tab 82)	12**
5-4	J1 and J10 Pin Assignments	13**
6-1	-Head Load and Door Interlock Switch	6-2
6-2	Differential Read Signal For Entire Track	6-3
6-3	Differential Read Signal For Portion of Outer Track	6-3
6-4	Write Data and Head Write Voltage For Outer Track	6-3
6-5	Base and Chassis Support Assembly	6-5
6-6	Carriage-Stop Adjustment	6-6
6-7	Write Splice Bit To Index Timing	6-6
6-8	Head Alignment Amplitude	6-8
6-9	Chassis Base Assembly	6-9
6-10	Disk Load Solenoid	6-10
6-11	Spindle and Cone	6-11
6-12	Base Casting Assembly	6-14
6-13	Head-Load-Pad Replacement Illustration	6-16
6-14	Solenoid Adjustment	6-17

LIST OF TABLES

TABLE NO.	TITLE	PAGE
4-1	Phase Sequence of Stepper Motor	4-4
4-2	Input/Output Lines	4-7

**Page numbers refer to 75897464, all others refer to 75897465.

Refer to Section 1 of 75897465.

OPERATION

2

Refer to Section 2 of 75897465.

INSTALLATION AND CHECKOUT

3

3.4.1 INPUT-OUTPUT CABLE

The maximum cable length from connector to connector is 25 feet. All inputs and outputs require pairs, one line for function, one for ground. The characteristic impedance is typically 120 ohms.

The information relative to the I/O connector (J1) and pin/signal assignments are defined in Figures 5-2 and 5-4.

The recommended mating connectors for Tab 82 are:

<u>TYPE OF CABLE</u>	<u>MANUFACTURER</u>	<u>CONN. P/N</u>	<u>CONTACT P/N</u>
Twisted Pair, #26 (crimp or solder)	AMP	1-583717-1	583616-5 (crimp) 583854-3 (solder)
Twisted Pair #26 (solder term.)	VIKING	3VH25/1JN-5	NA
Flat Cable	3M "Scotchflex"	3415-0001	NA

The recommended mating connector for Tab 64 is AMP P/N 86916-2.

On models configured for daisy-chain operation, the terminating resistor module RM1 (See Figure 5-3) is to be installed in the end FDD (farthest from the controller) ONLY. Terminators in more than one FDD during daisy-chain hookup may result in damage to the controller. For multiple-drive daisy-chain operation the resistor modules of all but the end unit must be removed from their sockets. Addresses of the FDD's are established by punching-out all but the desired shunt which corresponds to the drives' addresses (refer to Figure 5-3). For Unit 1 leave shunt 1, for Unit 2 leave shunt 2, etc.

3.4.2 DC POWER CONNECTION

DC power (user-supplied) comes through a stranded wire, 18 AWG minimum cable which interfaces with its mating connector on the printed-circuit board. The pin assignments are shown on Sheet 1 of the schematic Figure 5-2 and on Figure 5-4.

Mating connector:

Tab 064

<u>MANUFACTURER</u>	<u>CONNECTOR P/N</u>	<u>CONTACT P/N</u>
AMP	1-87270-1	87278-2

Tab 082

<u>MANUFACTURER</u>	<u>CONNECTOR P/N</u>	<u>CONTACT P/N</u>
AMP	1-480270-0	60619-1

THEORY OF OPERATION	4
---------------------	---

Refer to Section 4 of 75897465.

DIAGRAMS	5
----------	---

NOTE

PWA and Schematic diagrams for TMA Tab No. 64 units replacing their counterparts in Section 5 of the standard 9404B manual, are shown as Figure 5-2 and 5-3a of this package.

The PWA for the TMA Tab 82 unit replacing the Section 5 PWA in the standard manual is shown as Figure 5-3b here. The Tab 82 schematic is identical to that contained in the standard manual.

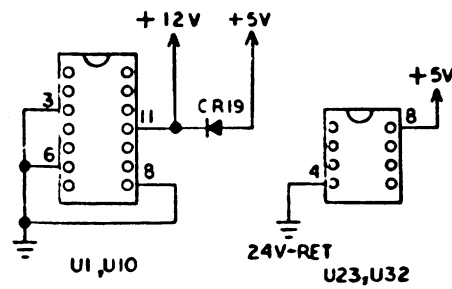
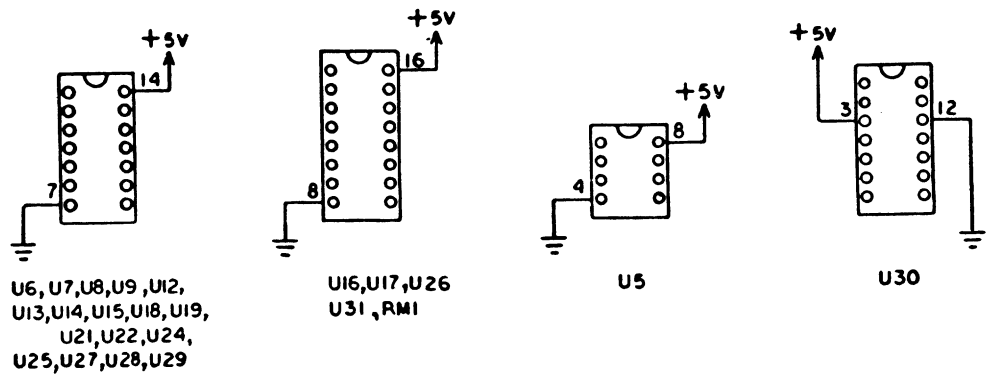

FIGURE 5-2. SCHEMATIC, MOD-T (SHEET 1 OF 6)

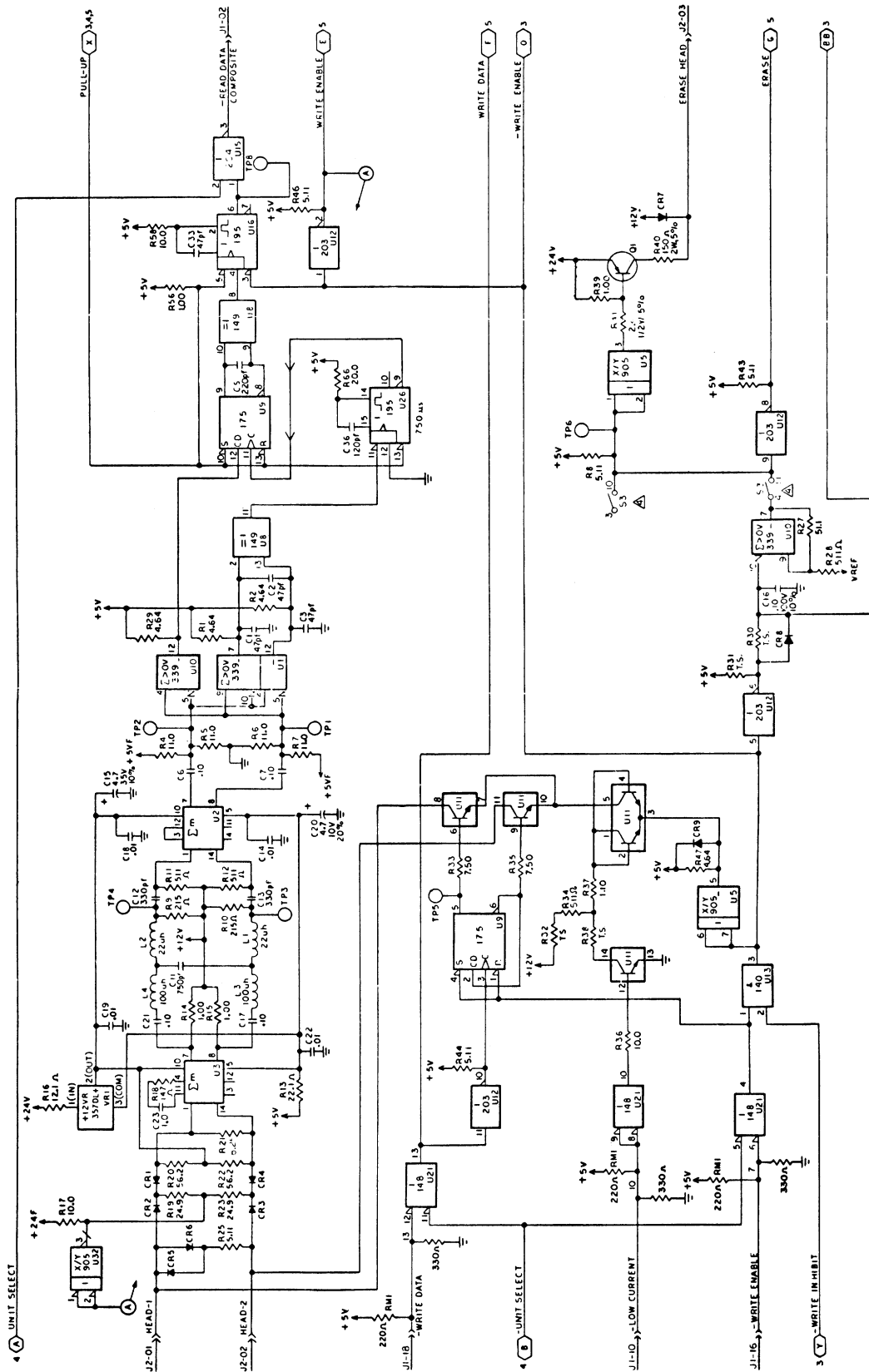

FIGURE 5-2. SCHEMATIC, MOD-T (SHEET 2 OF 6)

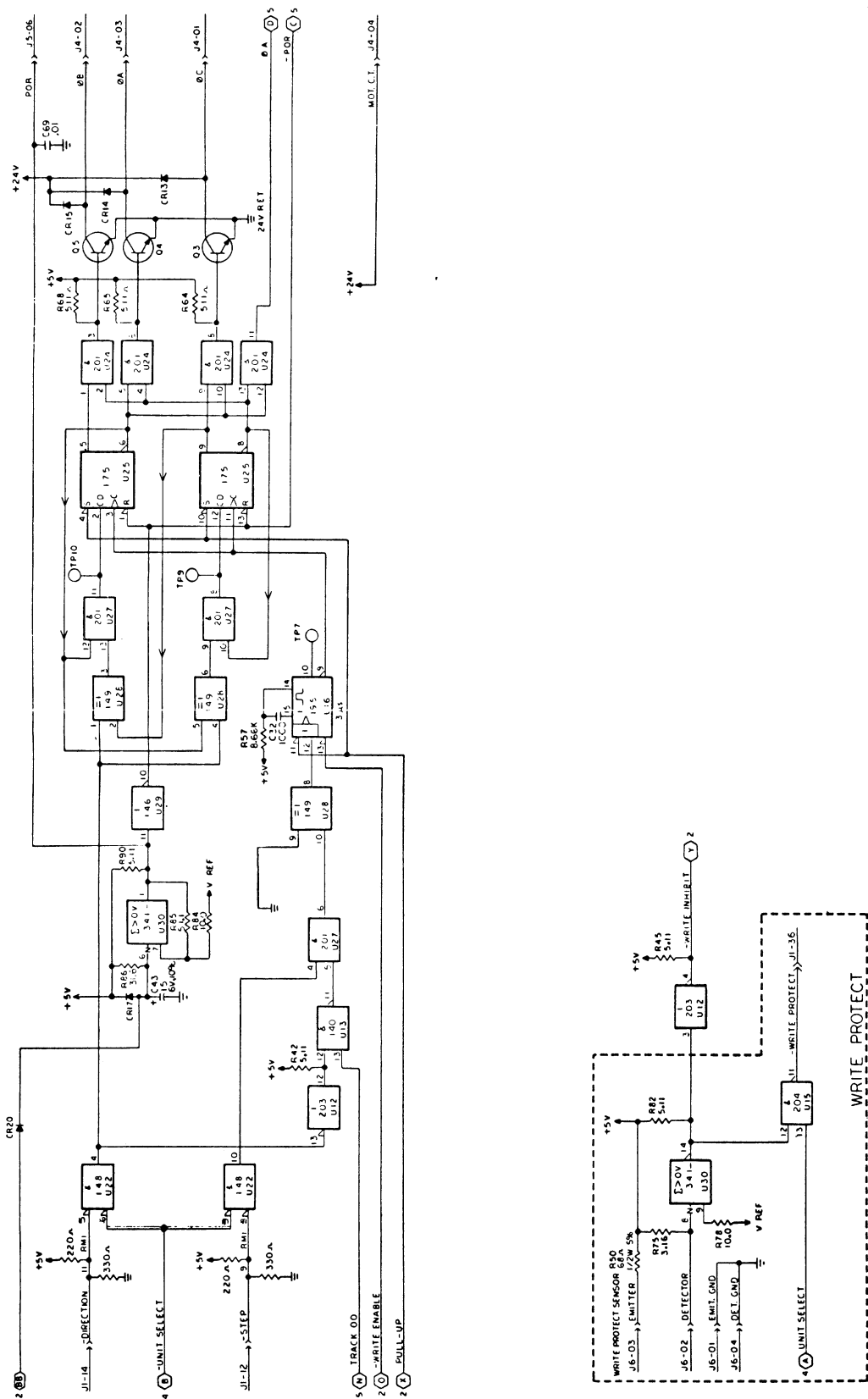

FIGURE 5-2. SCHEMATIC, MOD-T (SHEET 3 OF 6)

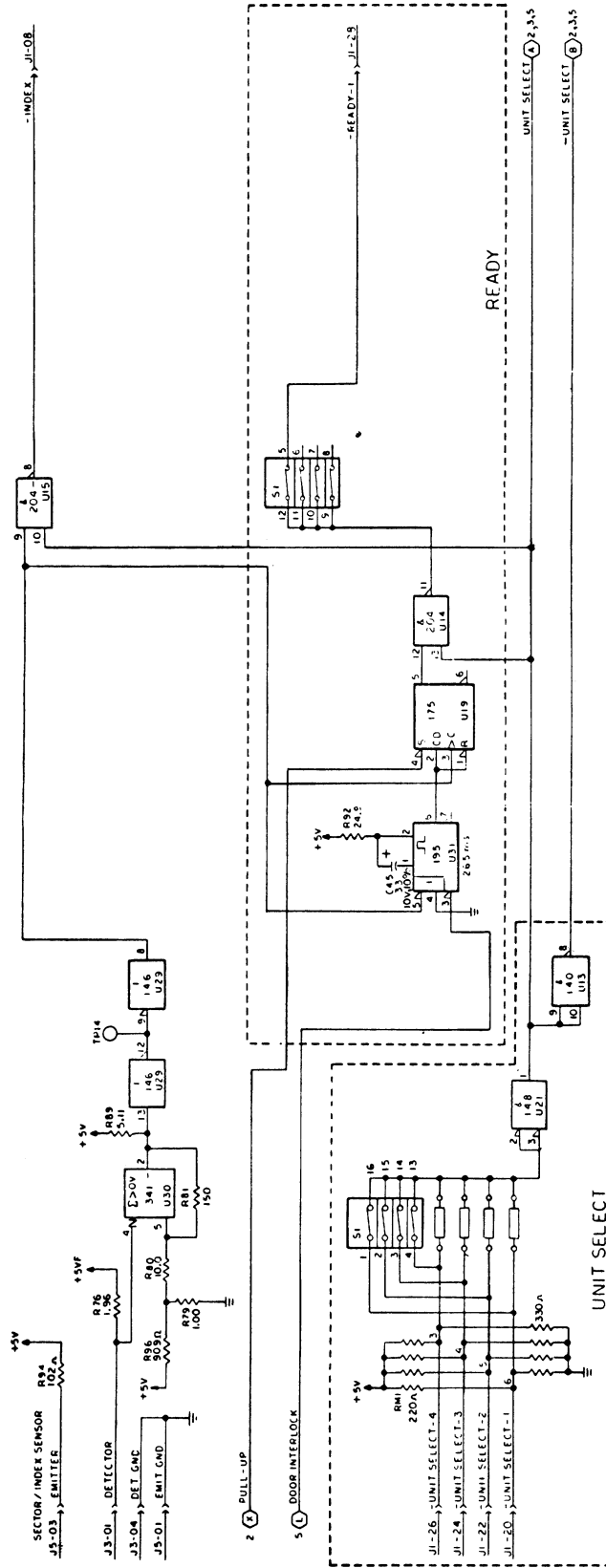

FIGURE 5-2. SCHEMATIC, MOD-T (SHEET 4 OF 6)

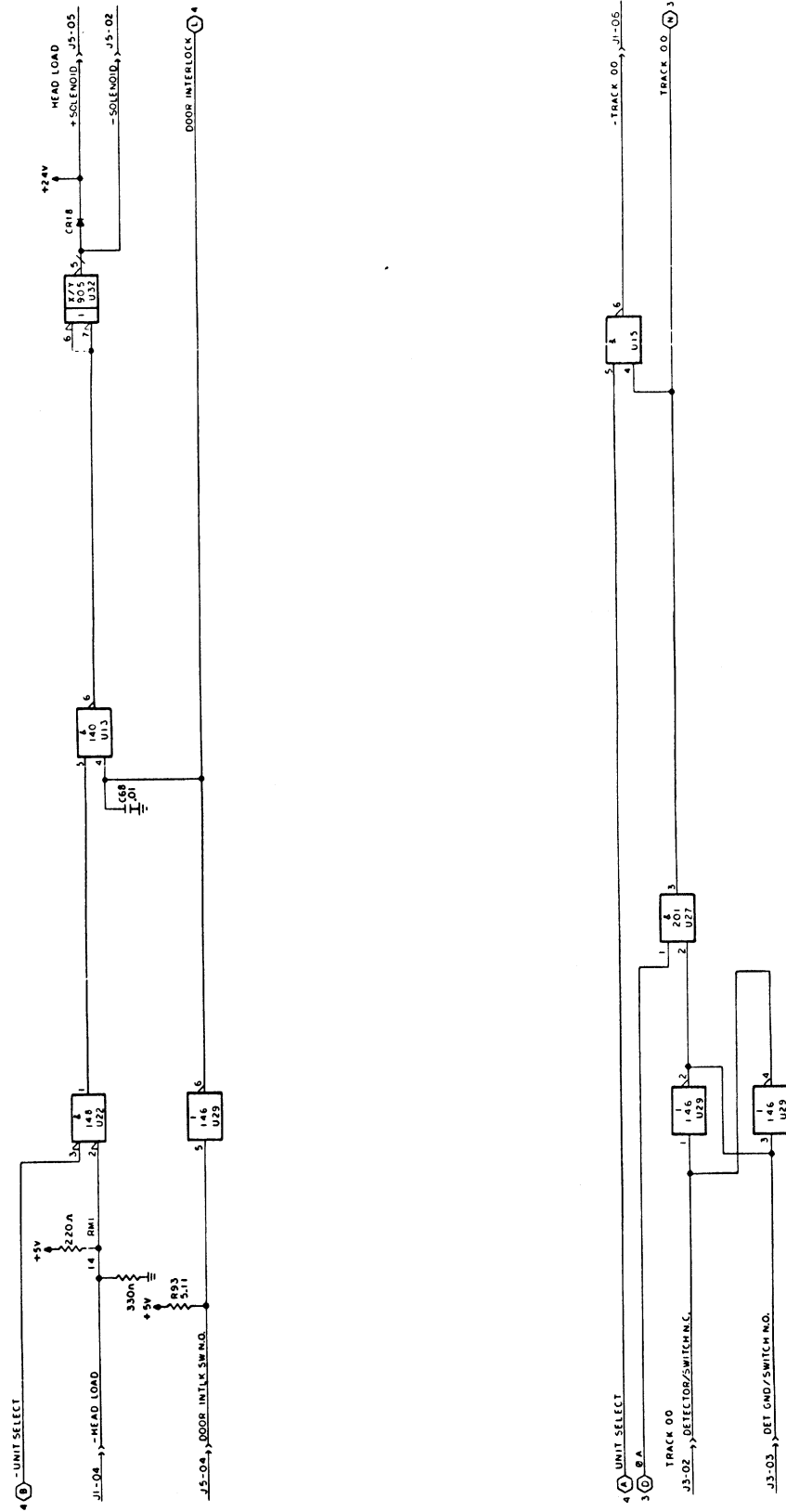

FIGURE 5-2. SCHEMATIC, MOD-T (SHEET 5 OF 6)

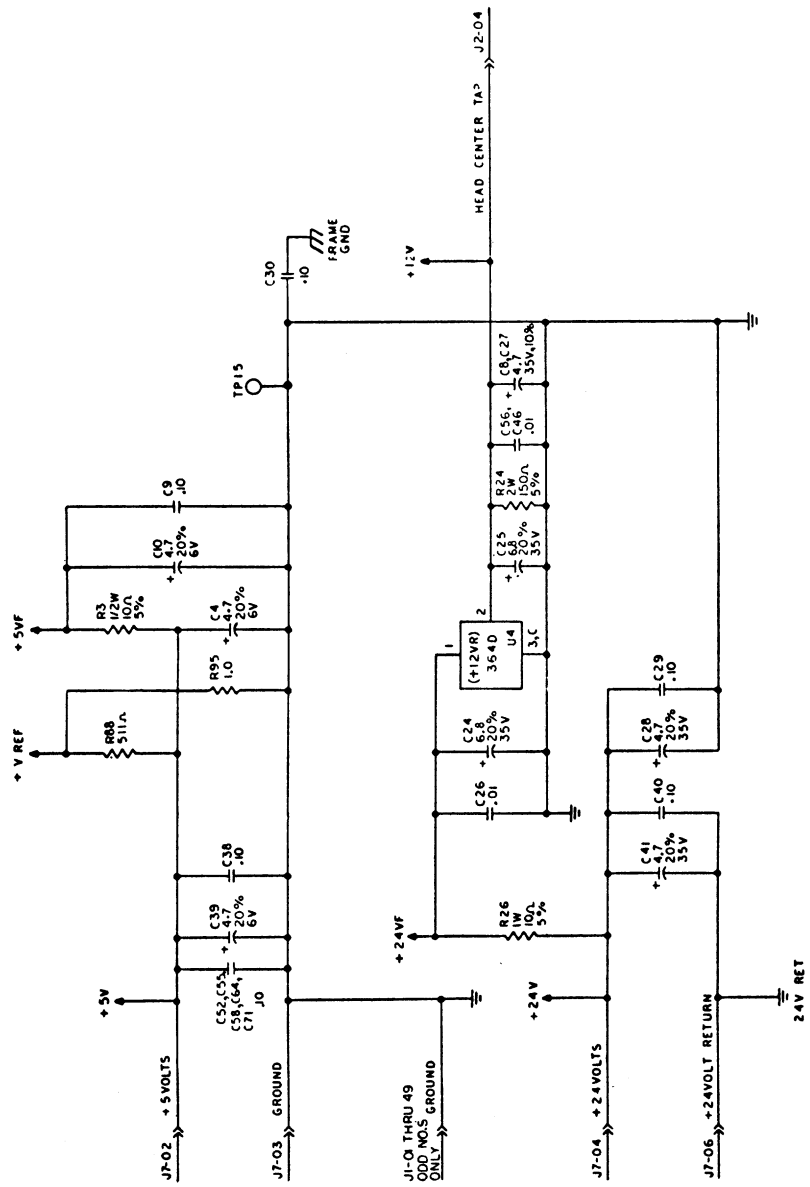
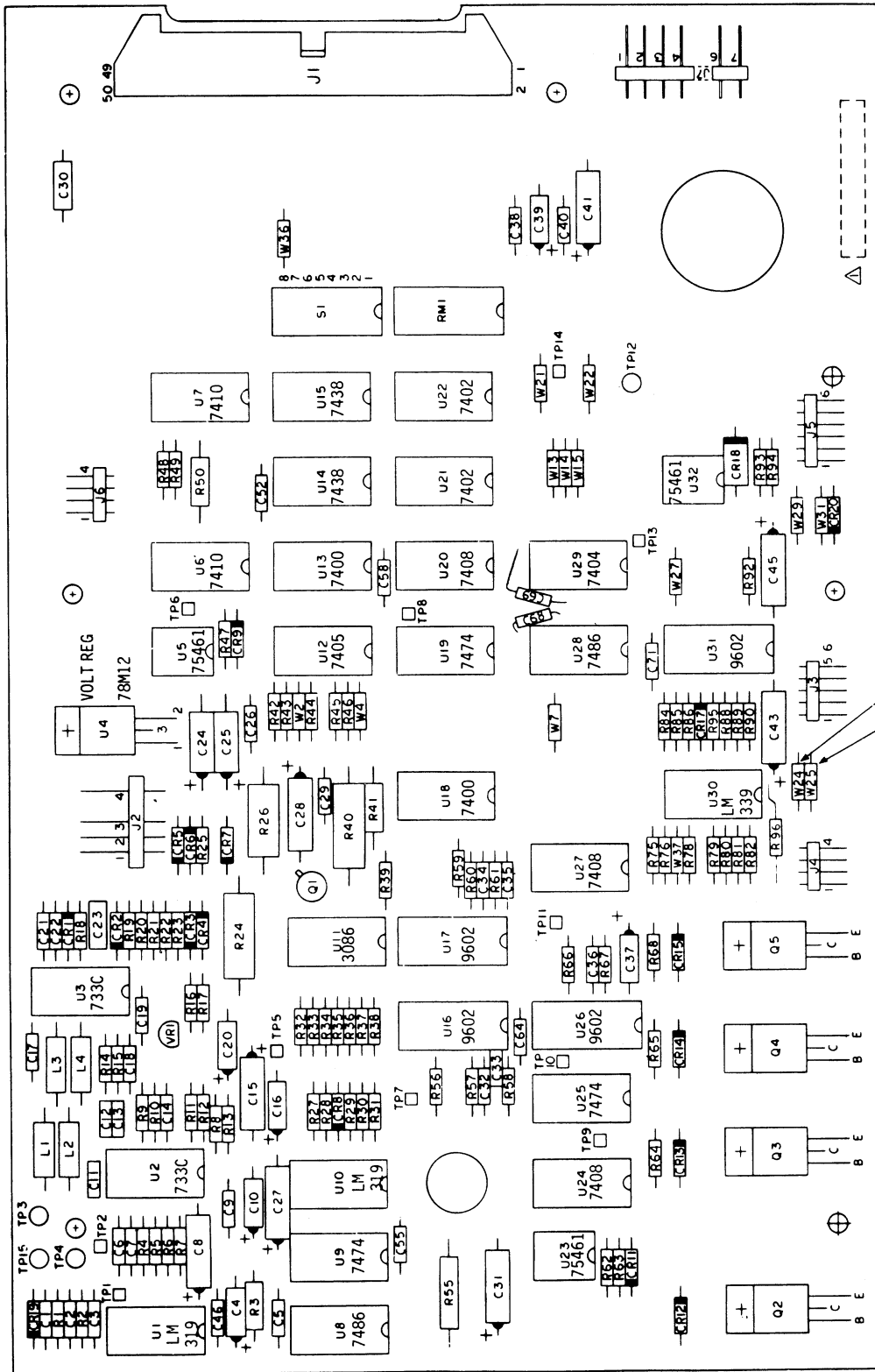

FIGURE 5-2. SCHEMATIC, MOD-T (SHEET 6 OF 6)



- DIODES**
- CR1, CR2, CR3 } 1N914A
 - CR4, CR5, CR6 } 1N4001
 - CR7, CR8, CR9, CR17 } 1N4001
 - CR11, CR12, CR13 } 1N4001
 - CR14, CR15, CR19 } 1N4001
 - CR18 - DIODE, SILICON
 - CR20 - 1N770

- TRANSISTORS**
- Q1 - 2N2907A
 - Q2 - TIP125
 - Q3, Q4, Q5 - T1 P120

Z276a

FIGURE 5-3A. ASSEMBLY (SHEET 1 OF 3)
PWA MOD-T (CONV. - I)

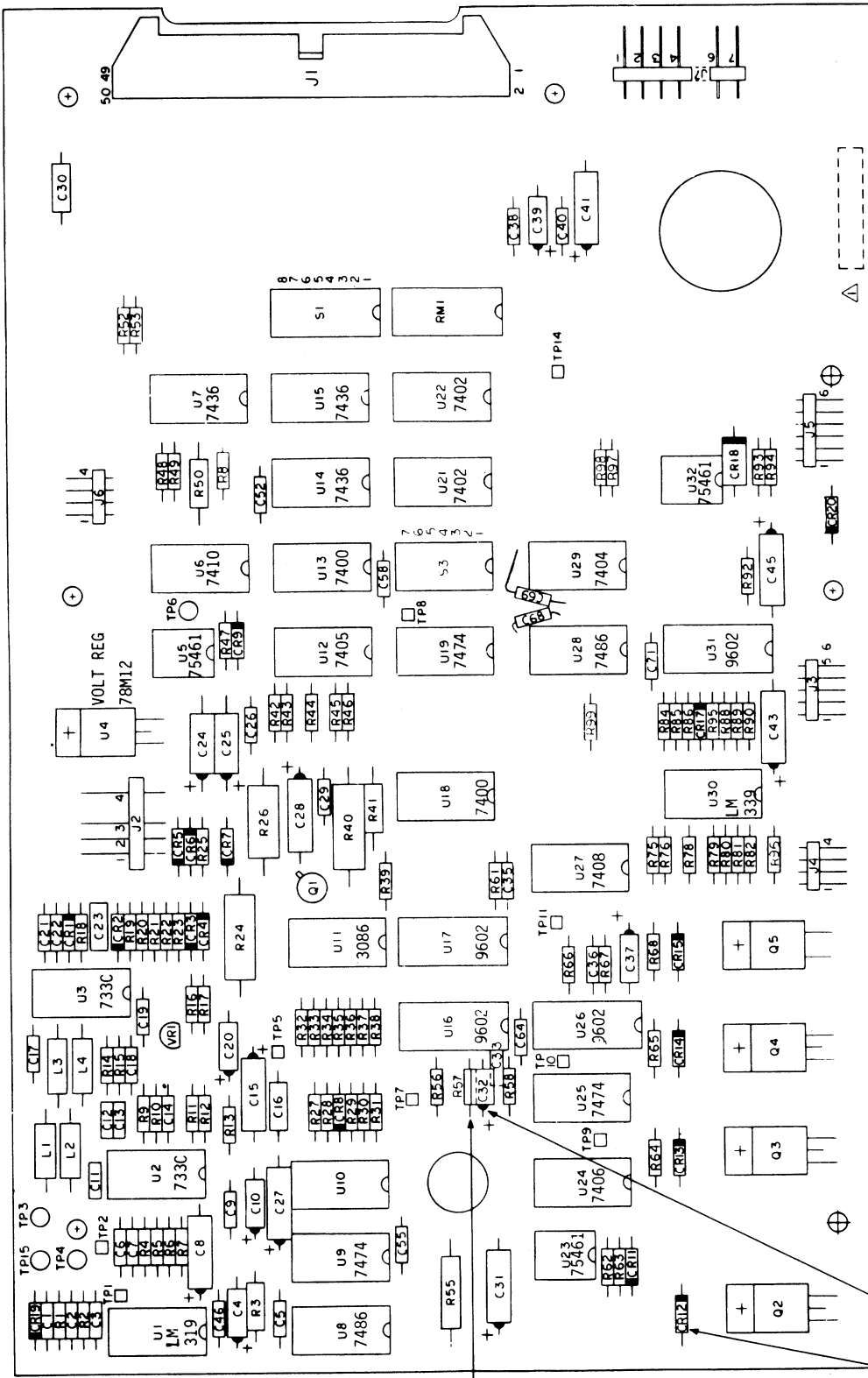
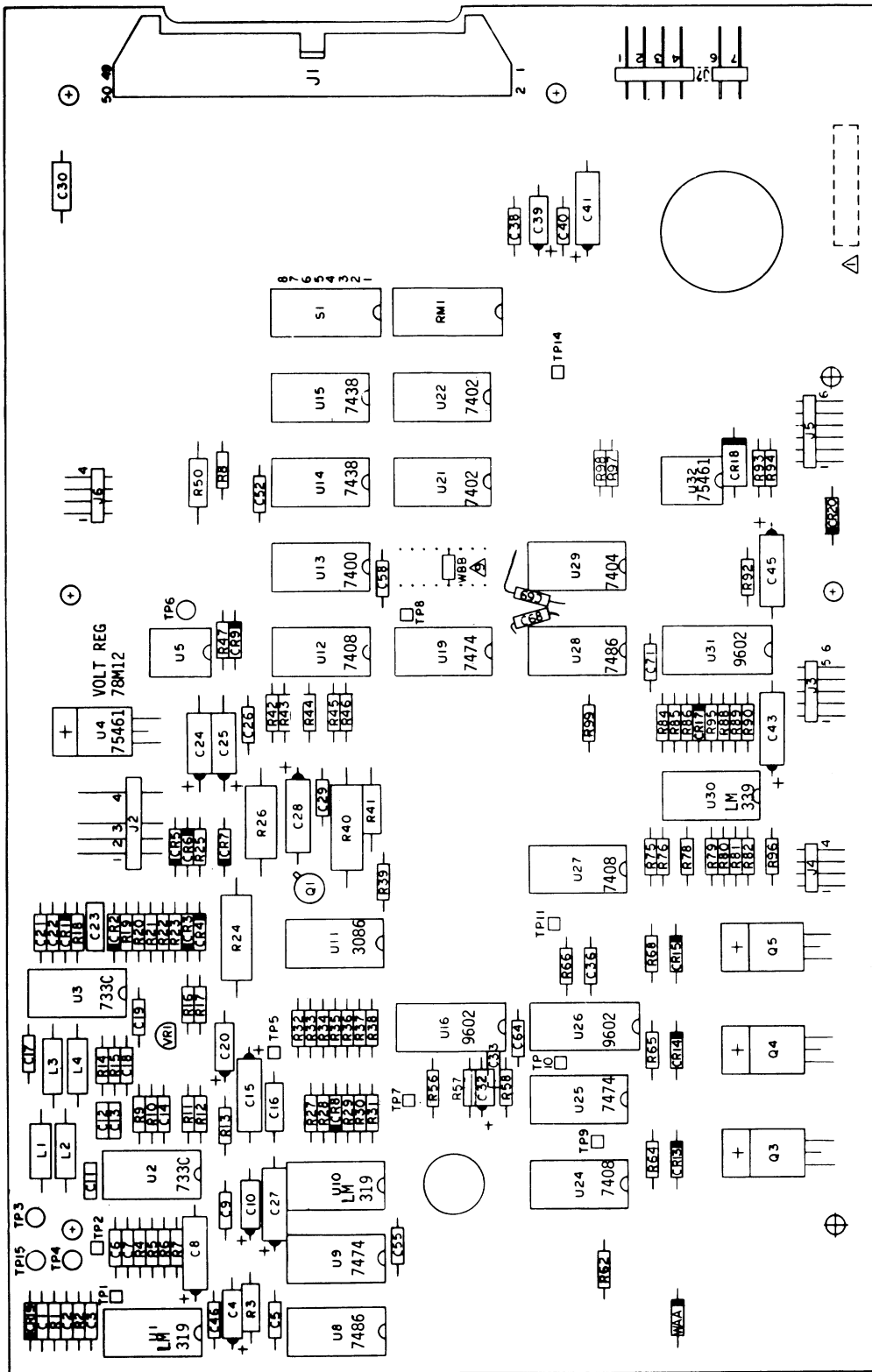

FIGURE 5-3A. ASSEMBLY (SHEET 2 OF 3)
PWA MOD-T (CONV -P-G)

- DIODES**
- CR1, CR2, CR3 } IN914A
 - CR4, CR5, CR6 } IN914A
 - CR17, CR7, CR8, CR9 } IN914A
 - CR11, CR12, CR13 } IN4001
 - CR14, CR15, CR19 } IN4001
 - CR18 - DIODE, SILICON
 - CR20 - IN770

- TRANSISTORS**
- Q1 - 2N2907A
 - Q2 - T1P125
 - Q3, Q4, Q5 - T1P120



- DIODES**
- CR1, CR2, CR3, CR17 } 1N914A
 - CR4, CR5, CR6 } 1N4001
 - CR7, CR8, CR9 } 1N4001
 - CR13, CR14, CR15 } 1N4001
 - CR19 } 1N4001
 - CR18 - DIODE, SILICON
 - CR20 - 1N770

- TRANSISTORS**
- Q1 - 2N2907A
 - Q3, Q4, Q5 - T1P120

FIGURE 5-3A. ASSEMBLY (SHEET 3 OF 3)
PWA MOD-T

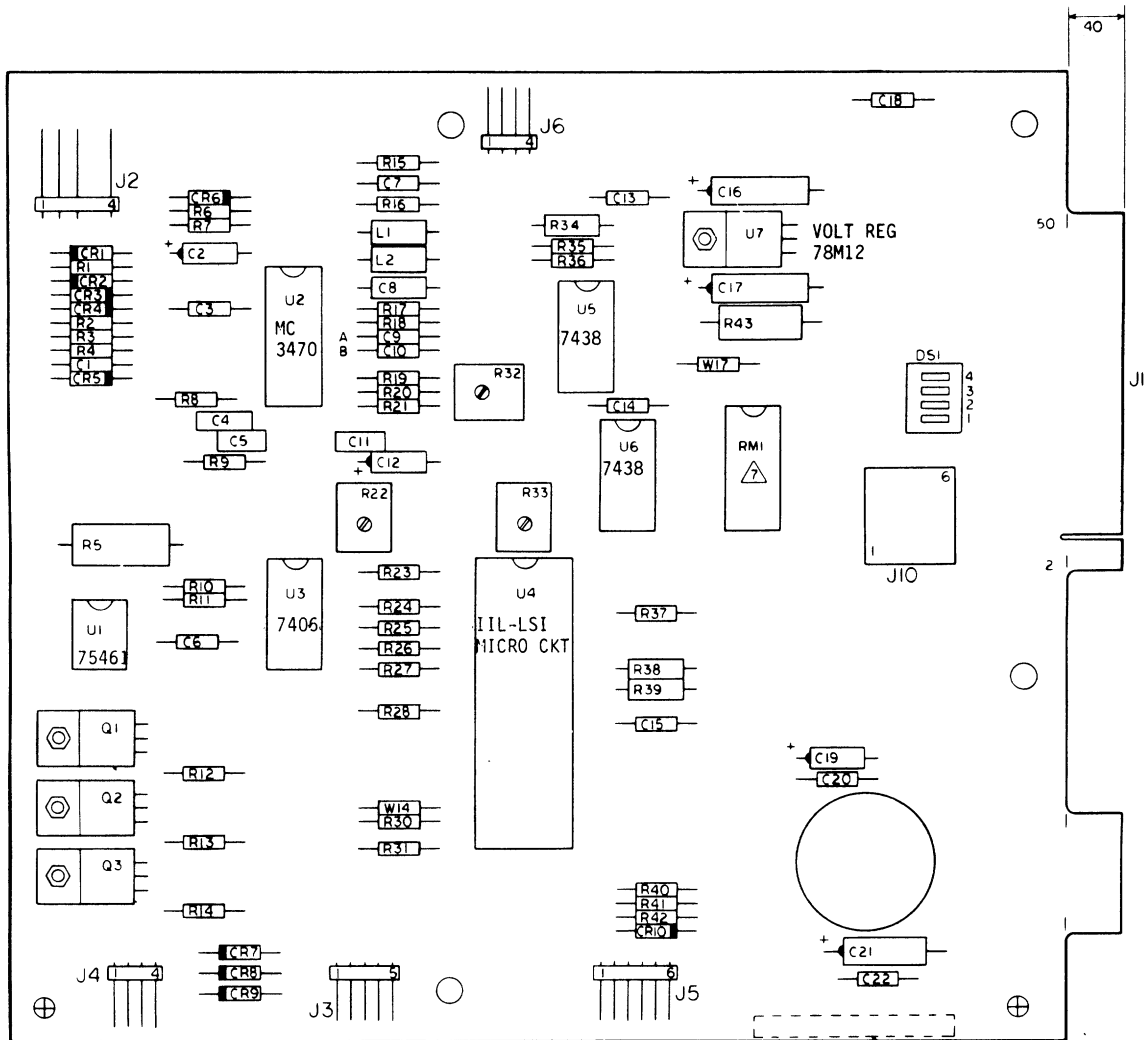

TRANSISTORS

Q1, Q2, Q3 - T1P120

DIODES

CR1, CR2, CR3	} 1N914A
CR4, CR5	
CR6, CR7, CR8	} 1N4001
CR9, CR10	

2279a

FIGURE 5-3B. PWA 1X-FDD-LSI-T

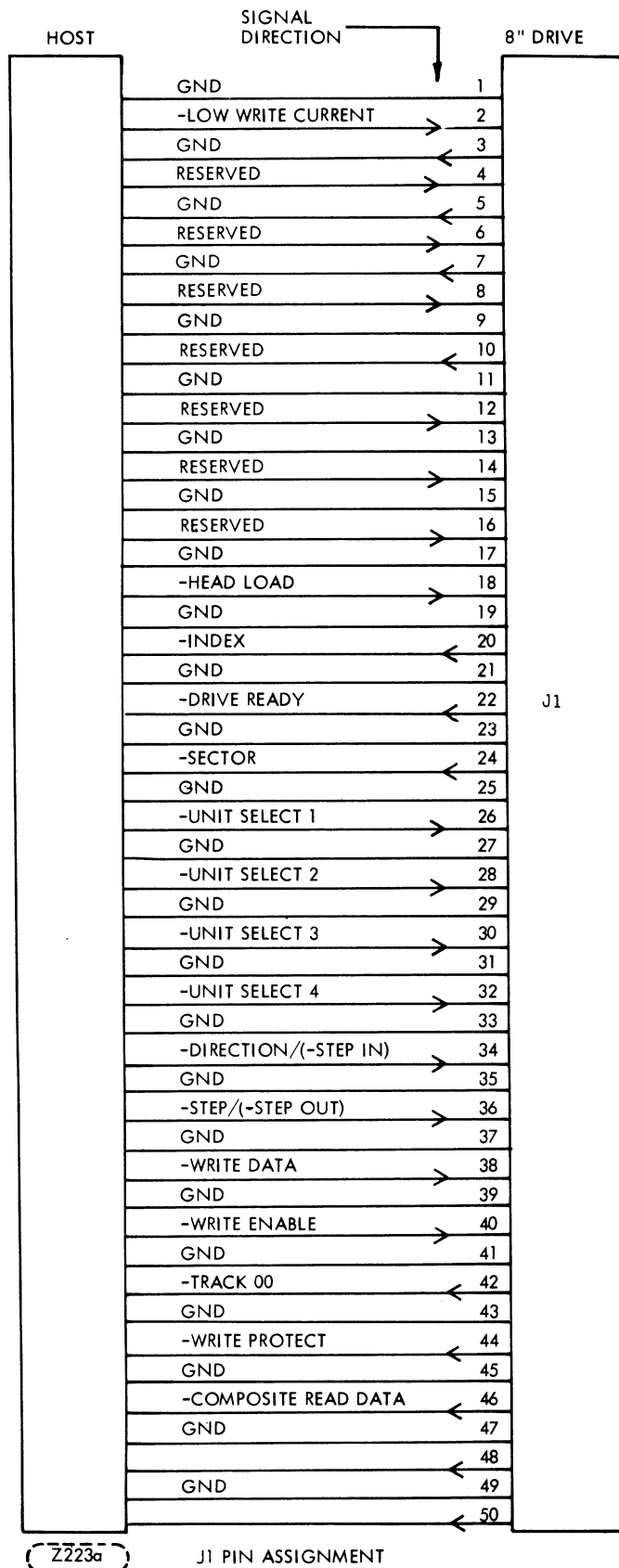

Z223a

J1 PIN ASSIGNMENT

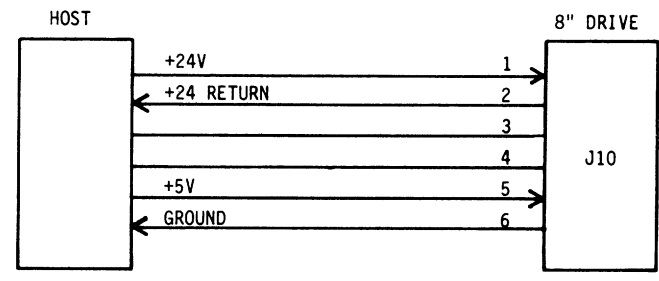

Z223c

J10 PIN ASSIGNMENT

FIGURE 5-4. J1 AND J10 PIN ASSIGNMENTS

NOTE

(For TMA 75744064)

Throughout Section 6, when certain parameters are discussed, make the following substitutions:
use Test Point 3 instead of TPA;
use Test Point 4 instead of TPB;
use J1-08 instead of J1-20.

6.6.8 WRITE PROTECT ASSEMBLY ADJUSTMENT (WHERE APPLICABLE)

This adjustment will be required whenever the unit is dis-assembled, or a different style diskette is utilized in the unit.

- a. With a Write Protected diskette installed in the unit (Write Protect slot uncovered), monitor U30 pin 14/R82-East for the WRITE PROTECT signal. A continuous logically high signal will be present whenever the Write Protect assembly is properly adjusted. A logically low signal will appear if not properly adjusted.
- b. To adjust, loosen the two hex-head screws holding the sensor mount in place. With the front panel door open, push down on the disk load arm (Figure 6-9) to insure that the disk is in the loaded position (Figure 6-10). At the same time, grasp the end of the envelope and move from side-to-side, and forward and backward while observing the WRITE PROTECT signal at pin U30 pin 14/R82-East. Adjust the mount until the WRITE PROTECT signal is present for any position of the envelope.
- c. Tighten the mount screws, and re-check to verify signal under all conditions of envelope position.

6.7.1 PRINTED CIRCUIT BOARD (PWA)

Tab 064

- a. Disconnect I/O Cable from J1 (refer to Figure 6-1).
- b. Disconnect DC power cable and AC power cable.
- c. Disconnect harnesses from connectors on printed circuit board.
- d. Remove two screws from printed circuit board adjacent to connector J1 (Figure 6-12).
- e. Remove PWA by detaching it from the four push-in clips. (See Figure 6-12).
- f. To replace printed circuit board push clips through printed circuit board.
- g. Replace two screws adjacent to connector J1.
- H. Reconnect harness and I/O cable.
- i. Perform Burst to Index Check and adjust is necessary (paragraph 6.6.2).

Tab 082 same as 9404B.

Refer to Section 7 of 75897465.

Parts data for Tabs 64 and 82 are as defined in Section 8 of the 9404B manual. The Parts Data section however, has a unique publication number (77834771) which is included as an integral part of the 9404B manual 75897465.

Before using the Parts Data, read the instructions carefully to ensure its proper use.





**CONTROL DATA®
FLEXIBLE DISK DRIVE
MODEL 9404-B**

**GENERAL DESCRIPTION
OPERATION
INSTALLATION AND CHECKOUT
THEORY OF OPERATION
DIAGRAMS
MAINTENANCE
WIRE LISTS
PARTS DATA**

MAGNETIC PERIPHERALS INC.

 a subsidiary of
CONTROL DATA CORPORATION



PREFACE

This manual provides the information needed to install, operate and maintain the Control Data Corporation Model 9404B Flexible Disk Drive (FDD) and is intended to support customer engineers who require detailed information about the Flexible Disk Drive's operation.

The total content of the manual is comprised of two publications, each having a unique publication number, and is contained in one volume. The Manual's publication number (75897465) is that of the front matter, Sections 1 (one) through 7 (seven). This number should be used when making reference to the 9404B Flexible Disk Drive Hardware Maintenance Manual. Section 8 (eight), Parts Data, is identified by the unique publication number 77834771.

A configurator sheet is provided on the following page which describes FDD configurations supported by this manual. Refer to the equipment nameplate located on the right-hand side of the unit (viewed from the front) to determine the appropriate Top Mechanical Assembly (TMA) and equipment (BR) identification numbers. Then use the Configurator sheet as a starting point to establish the maintenance level for the device.

FLEXIBLE DISK DRIVE CONFIGURATOR SHEET

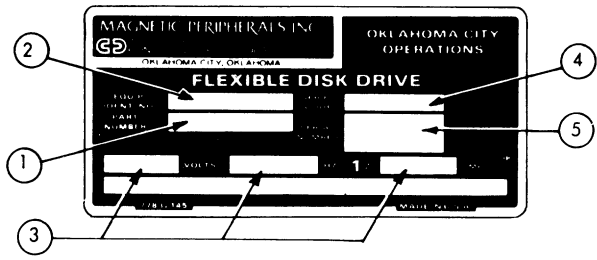

- ① TOP MECHANICAL ASSEMBLY NO. (TMA)
- ② MARKETING IDENTIFICATION NO. (MKTG ID)
- ③ AC POWER REQUIRED.
- ④ EQUIPMENT STATUS NUMBER
- ⑤ UNIT SERIAL NO.

POWER REQ	VDC	+5, +24 AT J7				
	VAC	120, 1Ø				
WRITE PROTECT						
TMA NO.		EQUIP. NO.				
75744080		BR8A5F		X	X	X
75744081		BR8A5G			X	X

Z265a

TABLE OF CONTENTS

SECTION	PAGE
GENERAL DESCRIPTION	
1.1 INTRODUCTION	1-1
1.2 PURPOSE AND USE OF EQUIPMENT	1-1
1.3 PRODUCT DESCRIPTION	1-1
1.3.1 Physical Description	1-2
1.3.2 Electrical Description	1-2
1.3.3 Performance Characteristics	1-2
OPERATION	
2.1 INTRODUCTION	2-1
2.2 OPERATING INSTRUCTIONS	2-1
2.2.1 Flexible Diskette Loading	2-1
2.2.2 Flexible Diskette Removal	2-1
2.3 ERROR RECOVERY	2-1
2.3.1 Seek Error	2-1
2.3.2 Write Error	2-1
2.3.3 Read Error	2-2
2.4 DISKETTE HANDLING RECOMMENDATIONS	2-2
INSTALLATION AND CHECKOUT	
3.1 INTRODUCTION	3-1
3.2 UNPACKING	3-1
3.3 INSTALLATION	3-1
3.4 CABLING AND CONNECTIONS	3-1
3.4.1 INPUT-OUTPUT CABLE	3-1
3.4.2 DC POWER CONNECTION	3-2
3.4.3 AC POWER CONNECTION	3-2
3.5 ENVIRONMENT	3-2
3.6 INITIAL CHECKOUT	3-3
THEORY OF OPERATION	
4.1 INTRODUCTION	4-1
4.2 GENERAL DESCRIPTION	4-1
4.3 FUNCTIONAL DESCRIPTION	4-3
4.3.1 Control Logic	4-3
4.3.2 Write Logic	4-5
4.3.3 Read Logic	4-5
4.3.4 Disk Drive	4-6
4.3.5 Read/Write Head	4-6
4.4 CONTROL AND DATA LINE CHARACTERISTICS	4-6
4.4.1 Logic Levels	4-6
4.4.2 Transmitter Characteristics	4-6
4.4.3 Line Receiver Characteristics	4-6
4.4.4 Control and Data Line Functions	4-6

SECTION

PAGE

DIAGRAMS AND MAINTENANCE AIDS

5.1	DIAGRAMS	5-1
5.2	MAINTENANCE AIDS	5-1
5.2.1	Introduction	5-1
5.2.2	Physical Description (Logic)	5-1
5.2.3	Use of Relative Level Indicators	5-1
5.2.4	Integrated Circuits	5-1

MAINTENANCE

6.1	INTRODUCTION	6-1
6.2	MAINTENANCE TOOLS	6-1
6.3	PREVENTIVE MAINTENANCE	6-1
6.4	HEAD CLEANING	6-1
6.5	TROUBLESHOOTING	6-2
6.5.1	DC Voltage and Signal	6-2
6.6	ADJUSTMENT PROCEDURES	6-4
6.6.1	Carriage-Stop Adjustment	6-4
6.6.2	Burst To Index Check and Adjustment	6-4
6.6.3	Actuator Alignment (Diskette)	6-7
6.6.4	Push-Rod Travel Adjustment	6-8
6.6.5	Door-Interlock Switch Adjustment	6-9
6.6.6	Disk-Load Bail Adjustment	6-10
6.6.7	Spindle and Cone Adjustment	6-11
6.6.8	Write Protect Assembly Adjustment (Where Applicable) ...	6-12
6.6.9	Track '00' Switch Adjustment	6-12
6.7	REMOVAL AND REPLACEMENT PROCEDURES	6-12
6.7.1	Printed Circuit Board (PWA)	6-13
6.7.2	Actuator Assembly	6-13
6.7.3	Drive-Motor Assembly	6-15
6.7.4	Head-Load-Pad Replacement	6-15
6.7.5	Solenoid Replacement and Tang Adjustment	6-15
6.7.6	Carriage and/or Stepper Motor Replacement	6-17

WIRE LISTS

7.1	INTRODUCTION	7-1
7.2	UPPER HARNESS ASSEMBLIES	7-1
7.3	LOWER HARNESS ASSEMBLY	7-1
7.4	STEPPER MOTOR	7-1
7.5	WRITE PROTECT	7-1

SECTION	PAGE
PARTS DATA	
8.1 INTRODUCTION	8-1
8.2 ILLUSTRATIONS	8-1
8.3 PARTS LISTS	8-1
8.4 TOP MECHANICAL AND ASSEMBLY LOCATION	8-1
8.4.1 Top Mechanical Assembly (TMA)	8-1
8.5 REPLACEMENT PARTS	8-1
8.6 PARTS LIST INSTRUCTIONS	8-11
8.6.1 Illustration Parts Lists	8-11
8.6.2 Top-Down Assembly/Component Parts Lists	8-11
8.6.3 Cross Reference Index	8-11
8.6.4 Sheet Number Referencing	8-11

LIST OF ILLUSTRATIONS

FIGURE NO.	TITLE	PAGE
2-1	Diskette Installation	2-2
4-1	Functional Block Diagram	4-2
5-1	Timing	5-2
5-2	Schematic	5-3
5-3	Assembly and Parts List	5-5
5-4	J1 and J7 Pin Assignments	5-6
6-1	-Head Load and Door Interlock Switch	6-2
6-2	Differential Read Signal For Entire Track	6-3
6-3	Differential Read Signal For Portion of Outer Track	6-3
6-4	Write Data and Head Write Voltage For Outer Track	6-3
6-5	Base and Chassis Support Assembly	6-5
6-6	Carriage-Stop Adjustment	6-6
6-7	Write Splice Bit To Index Timing	6-6
6-8	Head Alignment Amplitude	6-8
6-9	Chassis Base Assembly	6-9
6-10	Disk Load Solenoid	6-10
6-11	Spindle and Cone	6-11
6-12	Base Casting Assembly	6-14
6-13	Head-Load-Pad Replacement Illustration	6-16
6-14	Solenoid Adjustment	-17

LIST OF TABLES

TABLE NO.	TITLE	PAGE
4-1	Phase Sequence of Stepper Motor	4-4
4-2	Input/Output Lines	4-7

1.1 INTRODUCTION

The Model 9404B single-sided LSI Flexible Disk Drive (FDD) is a compact, portable, random access, data storage device that interfaces with a central processor via a control unit. Input/Output data and control signals are transmitted by means of an I/O cable.

1.2 PURPOSE AND USE OF EQUIPMENT

Data, in the form of magnetized bits, is written on, or read from the tracks of a rotating diskette. The FDD uses a single, flexible, removable diskette (one recording surface) enclosed in a sealed jacket. The unit is capable of hard-sector or soft-sector format operation.

1.3 PRODUCT DESCRIPTION

The major FDD components are the spindle, disk drive motor, read/write head, stepping motor, track-indexing device, and printed-circuit board.

A write-protect option is offered.

All FDD components are mounted on a base assembly. The front panel has a spring-loaded door through which the diskette is installed. The door is mechanically linked to the disk loading mechanism and the head-load interlock switch; therefore, when the door is closed the Read/Write head may be loaded on the diskette in preparation for the transfer of data.

Star- versus Daisy-Chain-Connected Configurations - Throughout this manual certain features and operations of the Flexible Disk Drive are described in terms of the manner in which the FDD is configured for connection to its controller, either star or daisy chain.

Star-configured devices are designed to be connected to their associated controller in "star" fashion wherein each FDD unit has its own complete umbilical cable connection to the controller, with no interconnection between FDD units. Star units are always in a ready state for reading or writing operation after initial preparation and turn on.

Daisy-chain-configured devices allow one to four FDD units to be connected serially to a common controller. The controller monitors the operational readiness of any selected FDD in its chain and commands and controls the reading and writing operation.

1.3.1 PHYSICAL DESCRIPTION

The physical dimensions for the equipment are as follows:

Height	4.97 in. (126.2 mm)
Width	8.78 in. (223.0 mm)
Depth	14.24 in. (361.7 mm)
Weight	12 lbs. (5.44 kgm)

1.3.2 ELECTRICAL DESCRIPTION

The electrical specifications for the equipment are as follows:

- DC Power Source (Supplied by Host Equipment)
 - +24 Volts ($\pm 10\%$) @ 1.3 A Typical
 - +5 Volts ($\pm 5\%$) @ 0.7 A Typical
- AC Power Source - Refer to the FDD configurator or nameplate to determine AC Power requirements.

1.3.3 PERFORMANCE CHARACTERISTICS

The equipment specifications for the FDD are as follows:

- ACCESSING TIME

Maximum Access Time	775 ms
Maximum One-Track Access Time	25 ms
Average Access Time	268 ms

- RECORDING

Mode	Double Frequency	MFM
Density (nominal)	1836 BPI (72.3 BPmm) 3268 BPI (128.7 BPmm)	3672 BPI (144.6 BPmm) Outer Track 6536 BPI (257.3 BPmm) Inner Track

Data Transfer Rate	249,984 bits/sec	499,968 bits/sec
Bits/Byte	8	8
Bits/Track	41,664	83,328
Tracks	77	77
Sectors	Format Determined	Format Determined

- DATA CAPACITY

Bytes/Track	5,208	10,416
Bits/Track	41,664	83,328
Bits/Diskette	3,208,128	6,416,256

- FLEXIBLE DISKETTE

CDC 421-60W, Single Density, or Equiv.
CDC 423-60W, Double Density, or Equiv.

Diskette Dimensions

8 x 8 inches (203.2 x 203.2 mm)
(including jacket)

Usable Diskette Recording
Surfaces

1

Diskette Surface Diameter

7.88 in. (200.1 mm)

Recording Radii

Track 76 (inner) 2.0290 in. (515 mm) nominal
Track 00 (outer) 3.6123 in. (918 mm) nominal

Diskette Surface Coating

Magnetic Oxide

Diskette Velocity

360 r/min

- READ/WRITE HEAD

Head Unit

1

Track Width

0.013 in. (0.33 mm)

Track Spacing

0.02083 in. (0.529 mm)

Erase to Read/Write Gap

0.035 in. (0.889 mm)



2.1 INTRODUCTION

The FDD is under direct control of the input/output and power sources. No special start-up procedure is required. Operation is fully automatic and requires no normal operator intervention.

2.2 OPERATING INSTRUCTIONS

Verify that power and I/O cables are securely attached before operation.

2.2.1 FLEXIBLE DISKETTE LOADING

- a. Apply AC/DC power to unit.
- b. Open FDD door.
- c. Remove diskette from storage envelope as shown in Figure 2-1.
- d. On units with the Write-Protect option, be sure the Write-Protect slot in the jacket is open, as shown in Figure 2-1, if the diskette is to be write-protected.
- e. If a diskette with a Write-Protect slot is not utilizing the Write Protect (that is, it will be written on), the slot must be covered with a piece of tape which is opaque to infrared.
- f. Carefully slide diskette into FDD, as shown in Figure 2-1, until jacket is solidly against stops.
- g. Carefully close unit door. Ensure that jacket is properly seated, spindle has engaged diskette, and door is closed and latched.
- h. Protect the empty envelope from liquids, dust, and metallic materials.

2.2.2 FLEXIBLE DISKETTE REMOVAL

- a. Open FDD door to stop diskette rotation and disenagage spindle.
- b. Remove diskette from FDD and put it in its storage envelope.
- c. Close FDD door.

2.3 ERROR RECOVERY

The following paragraphs give information needed to recover from possible errors in equipment operation.

2.3.1 SEEK ERROR

Seek errors will rarely occur unless the stepping rate is significantly exceeded. In the event of a seek error, recalibration of track location can be achieved by repetitive Step Out commands until a Track 00 signal is received.

2.3.2 WRITE ERROR

To guard against degradation from imperfections in the media, no more than four attempts to write a record should be used when Read After Write errors are encountered. In the event a record cannot be successfully written within four attempts, it is recommended that the sector or track be labeled defective and an alternate sector or track assigned. If more than two defective tracks are encountered, it is recommended that the diskette be replaced.

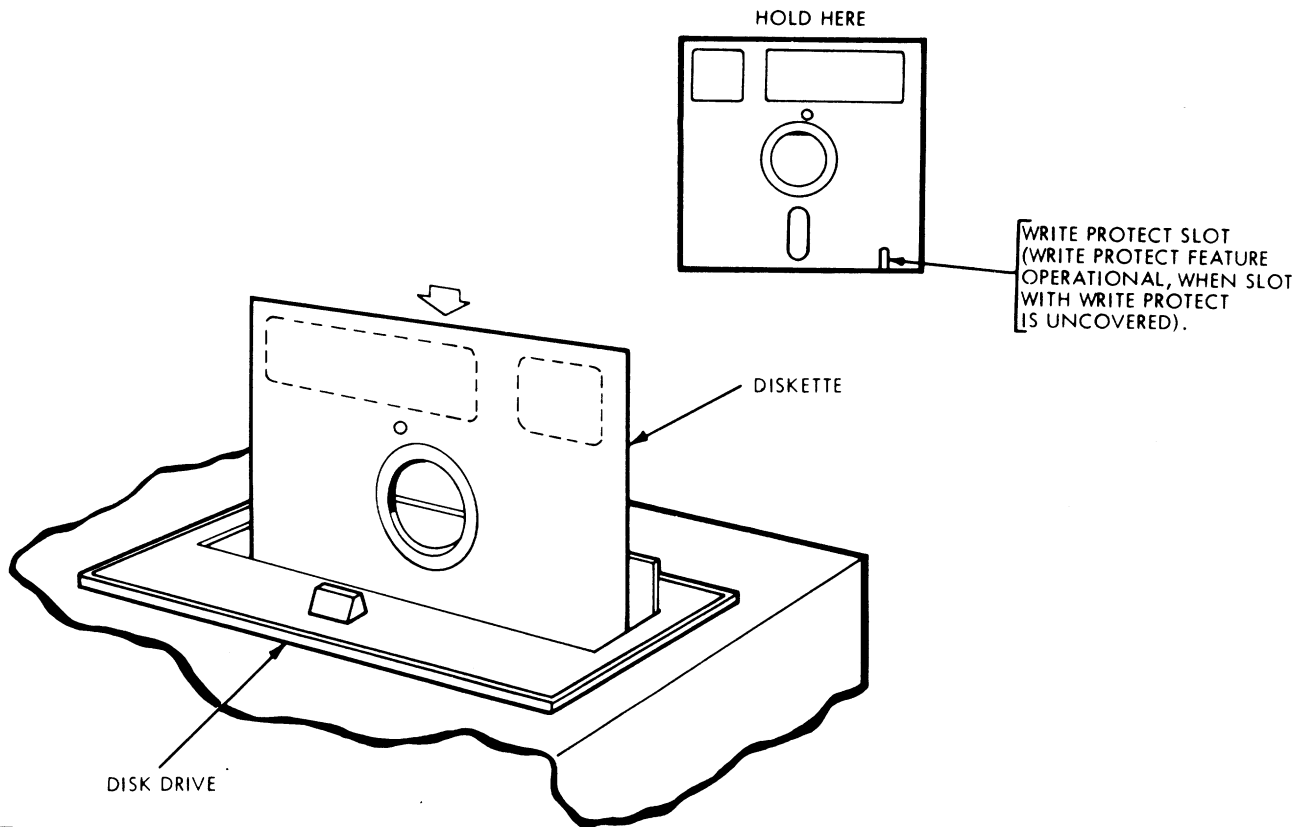

BB093

FIGURE 2-1. DISKETTE INSTALLATION

2.3.3 READ ERROR

In the event of a Read error, up to 10 attempts should be made to recover with re-reads. If after 10 attempts the data has not been recovered, step the head several tracks away and then reposition to recover the data. Unloading the head when data transfers are not imminent will increase the data reliability and extend the diskette life.

2.4 DISKETTE HANDLING RECOMMENDATIONS

Since the recorded diskette contains vital information, reasonable care should be exercised in its handling. Longer diskette life and trouble free operation will result if the following recommendations are followed.

- a. Do not use a writing device which deposits flakes, e.g., lead or grease pencils, when writing on diskette jacket label.
- b. Do not fasten paper clips to diskette jacket edges.
- c. Do not touch diskette surface exposed by jacket slot.
- d. Do not clean diskette in any manner.
- e. Keep diskette away from magnetic fields and from ferromagnetic materials that may be magnetized.

- f. Return diskette to envelope when removed from FDD.
- g. Protect diskette from liquids, dust, and metallic substances at all times.
- h. Do not exceed the following storage environmental conditions:

Temperature: 50° to 125°F (10° to 56.1°C)

Relative Humidity: 8% to 80%

Maximum Wet Bulb: 85°F (29.4°C)

- i. Diskettes should be stored in a box or cabinet when not in use.
- j. Remove diskette before applying or removing power to the FDD.



3.1 INTRODUCTION

This section provides the information and procedures necessary to put an FDD into operation.

3.2 UNPACKING

Unpack FDD as follows:

- a. Cut banding and lift top half of styrofoam shell from unit.
- b. Lift unit in polyethylene bag from bottom half of styrofoam shell and remove unit from polyethylene bag.

During unpacking, care must be used so that any tools being used do not inflict damage to the unit. As a unit is unpacked, inspect it for possible shipping damage. All claims for this type of damage should be filed promptly with the carrier involved. If a claim is filed for damages, save the original packing materials.

3.3 INSTALLATION

Install the FDD in the designated location in the host equipment.

3.4 CABLING AND CONNECTIONS

Connect the AC cable, I/O cable, and DC cable between the FDD and host equipment.

3.4.1 INPUT-OUTPUT CABLE

The maximum cable length from connector to connector is 25 feet. All inputs and outputs require pairs, one line for function, one for ground. The characteristic impedance is typically 120 ohms.

The information relative to the I/O connector (J1) and pin/signal assignments are defined in Figures 5-2 and 5-4.

The following mating connectors are recommended:

<u>TYPE OF CABLE</u>	<u>MANUFACTURER</u>	<u>CONN. P/N</u>	<u>CONTACT P/N</u>
Twisted Pair, #26 (crimp or solder)	AMP	1-583717-1	583616-5 (crimp) 583854-3 (solder)
Twisted Pair #26 (solder term.)	VIKING	3VH25/1JN-5	NA
Flat Cable	3M "Scotchflex"	3415-0001	NA

On models configured for daisy-chain operation, the terminating resistor module RM1 (see Figure 5-3) is installed in the end FDD (farthest from the controller) ONLY. Terminators in more than one FDD during daisy-chain hookup may result in damage to the controller. For multiple-drive daisy-chain operation, the resistor modules of all but the end unit must be removed. The addresses of additional FDD's are established by moving W1 to the W2 position for Unit 2 address, W3 for Unit 3 address, and W4 for Unit 4 address.

3.4.2 DC POWER CONNECTION

DC power (user-supplied) comes through a stranded wire, 18 AWG minimum cable which interfaces with its mating connector on the printed-circuit board. The pin assignments are on Sheet 1 of the schematic, Figure 5-2, and on Figure 5-4.

Mating connectors:

<u>MANUFACTURER</u>	<u>CONN. P/N</u>	<u>CONTACT P/N</u>
AMP	583873-1	583649-6 (Crimp) 583854-3 (Solder)
VIKING	3VH6/ICN-12	NA

3.4.3 AC POWER CONNECTION

The AC Power Cable consists of stranded wire, 18 AWG minimum with center pin connection utilized as frame ground. Mating connector:

PLUG:

AMP PN 1-480700-0

CONTACTS: (SOCKET)

AMP PN 350536-1 (STRIP)

AMP PN 350550-1 (LOOSE)

3.5 ENVIRONMENT

Operating and storage environments of the FDD are as follows:

Operating: 55° to 100°F (13° to 38°C) 12°F (6.7°C)/hr max. fluctuation
20% to 80% relative humidity
(providing there is no condensation).

Non-Operating: -30° to +150°F (-35° to 65°C)
5% to 95% relative humidity
(providing there is no condensation)
Max. Wet Bulb 80°F (27°C).

3.6 INITIAL CHECKOUT

This procedure should be used to determine that the FDD is operational. The procedure assumes that the unit is installed and the I/O and power cables are connected.

- a. Apply AC power to unit and visually check that the spindle rotates.
- b. Apply DC power to unit.
- c. Insert diskette as described in Section 2.
- d. Apply a head-load-command signal to the unit and close the access door. Check that the head-load solenoid actuates, and the door microswitch is actuated.
- e. Apply a stepping-command signal to the unit and check that the actuator steps the head as commanded.
- f. Remove diskette.
- g. Remove the command signals and power from the unit.



4.1 INTRODUCTION

The basic functions performed by the FDD are: (1) Receive and generate control signals; (2) Position the Read/Write head on selected tracks; and (3) Write or Read data upon command from the FDD controller. In the case of daisy-chain operation, these functions are accomplished upon selection after initial indication to the controller that the FDD is ready to operate and accept commands. With star operation, the FDD should be regarded as always selected.

The Theory of Operation for the FDD is divided into two parts. The first part gives a general theory of operation. The second part gives a detailed functional description of all major components both electronic and mechanical and describes all signals exchanged between the FDD and the controller.

4.2 GENERAL DESCRIPTION

The basic function of the FDD is to indicate to the controller when it is ready to operate and respond to the commands of the controller to: (1) Receive and generate control signals; (2) Position the Read/Write head to selected tracks; and (3) Write or Read data on the diskette when selected. The Write-Protect function described, which is an option, may not apply to your particular FDD model. (Refer to the Preface at the front of the manual.)

Signals received and transmitted by the FDD are shown in Figure 4-1, and explained in Table 4-2. All signals received by the FDD are gated with Unit Select so that no stepping, reading, or writing can be performed on an unselected FDD. All signals generated within the FDD are gated with Unit Select so that no signals can be transmitted from an unselected FDD.

During the write operation, the selected FDD receives Write Enable, Head Load, Write Data, and Low Current (Track 43 or greater) signals. During the read operation, the selected FDD will receive a Head Load command. The Write Enable line remaining high implies a read operation. Under these conditions, the FDD will transmit the Composite Read Data signal to the controller. Controller Step commands are received initiating a Track Seek operation on a selected FDD. The FDD transmits Index and Sector pulses as long as it is selected. Also, the selected FDD transmits a Track 00 signal to the controller whenever the Read/Write head is at Track 00.

Positioning of the carriage-mounted Read/Write head is accomplished by a lead screw driven by a stepper motor. Each step command from the user system increments the stepper motor which, in turn, rotates the lead screw 15 degrees. Each 15 degree rotation of the lead screw moves the Read/Write head one track position.

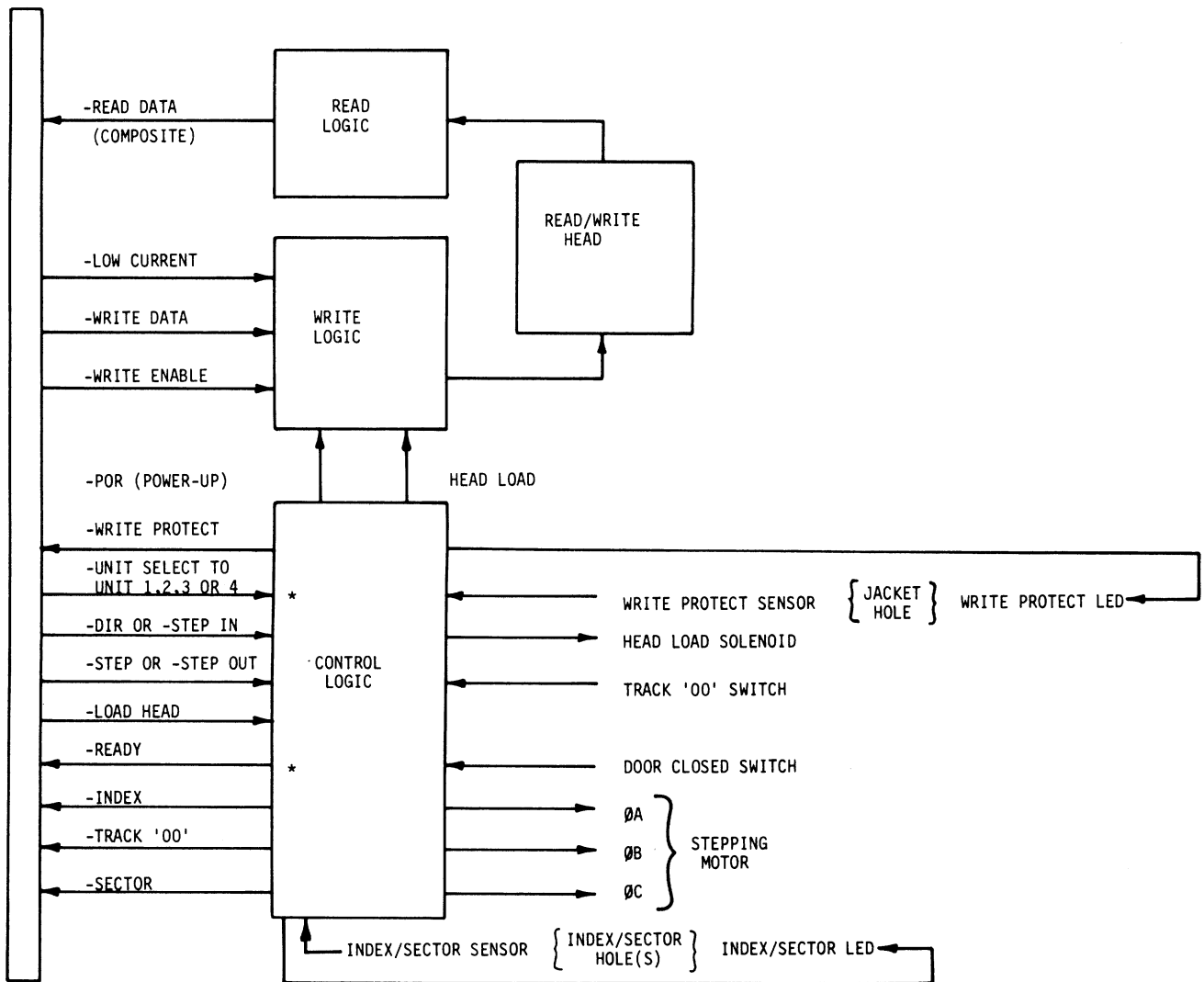

Z265b

* DAISY-CHAIN CONFIGURATION ONLY

FIGURE 4-1. FUNCTIONAL BLOCK DIAGRAM

A reading or writing operation begins by placing the Read/Write head in contact with the diskette with a Head-Load command and at the desired track. To write on the diskette, Write Enable is sent by the controller to condition the write logic. The write current then in the head, reverses polarity synchronous with the low-to-high transitions of the Write Data pulses from the controller. The current reversals cause magnetic flux reversals, the data and clock bits which are induced on the desired diskette track. Erasure of previously recorded data is simultaneously accomplished during the writing operation in addition to a delayed-tunnel-erase which ensures diskette interchangeability.

To read from the diskette, magnetized bits in the format of the prerecorded data are sensed by the Read/Write head. This signal is amplified, digitized, and transmitted to the user system as composite clock and data information.

The FDD utilizes an LSI control chip fabricated from "current-injection logic" (I²L) technology. The LSI circuit contains an internal oscillator-generated clock. This synchronous logic design controls all timing functions. Another LSI (read) chip performs the analog-to-digital conversion within the device.

4.3 FUNCTIONAL DESCRIPTION

Refer to Figures 4-1, 5-1, and the Schematic Diagram, Figure 5-2, for the following discussion.

The FDD is divided into the following major functional areas:

- a. Control Logic
- b. Write Logic
- c. Read Logic
- d. Disk Drive
- e. Read/Write Head

4.3.1 CONTROL LOGIC

The functions of the control logic are to generate the signals that (a) establish the ready status of the FDD, (b) step the Read/Write head in or out upon selection and command of the controller, (c) load the head on the disk for read/write operations, (d) protect the disk from writing if the write-protect slot is present, (e) indicate when the Read/Write head is at Track 00, (f) generate the Index and Sector pulses when the diskette is rotating and the FDD is selected, and (g) provide unit selection of the FDD.

- a. The Ready signal is generated when the diskette comes up to proper operating speed. The Index pulses are used to determine operating speed within LSI control chip U4. The Ready signal is present only when the FDD is selected.
- b. At initial voltage application, ϕA of the stepper motor is energized. Each step command received sequentially energizes one of the three phases of the stepper motor. Either the logic level of the direction signal or the use of Step In or Step Out signals determines whether the phase sequence is $\phi A, \phi B, \phi C, \phi A, \phi C, \phi B, \phi A$.

Movement of the Read/Write head is initiated by the step commands from the controller. The head is stepped one track, either toward the spindle (In) or away from the spindle (Out), with each step command. The direction is regulated by the status of the Direction line (a low level of the Direction line causes the Read/Write head to step toward the spindle, and a high level causes the Read/Write head to step away from the spindle) or by commanding either the Step-In or Step-Out Line.

Drive to the specific stepper-motor phases, ϕA , ϕB , and ϕC , is provided by logic-driven Darlington transistors Q1, Q2, and Q3.

The phase sequence through which the stepper motor is driven (see Table 4-1) is controlled by U4 pins 30, 31, and 32. During a phase change, the previously active phase from U4 remains on (or overlaps) 4.5 ms after the next (or new) phase is activated. Refer to Figure 5-1.

TABLE 4-1. PHASE SEQUENCE OF STEPPER MOTOR

Change the Active Phase ϕ		To Step
From	To	
A	B	IN
B	C	
C	A	
A	C	OUT
B	A	
C	B	

- c. The Read/Write head of a selected FDD can be loaded when the diskette is fully installed and the front panel door is closed. Closing the front-panel door actuates the door-interlock switch which enables the circuit to the head-load solenoid. When the controller sends a Head Load signal, the head-load solenoid is energized causing the armature bail to actuate. The actuation of the bail permits the head-load arm and its pressure pad, under tension, to hold the diskette surface against the Read/Write head. To operate without the head-load signal from the controller, add jumper W15.
- d. The Write Protect function is accomplished through use of an LED (light-emitting diode) and a photo-transistor. These are mounted such that the presence of a write protect slot in the jacket of the diskette will cause pins 1 and 2 of gate U5 to be driven low. This signal is gated with Unit Select at the interface. Write Protect will inhibit writing on any diskette possessing a write-protect slot by shunting write current from the write-current injection pin (8) of U4.
- e. The Track 00 signal is generated when the carriage assembly closes the Track 00 switch. Closing this switch sets the latch formed by the two gates of U3 pin 3 and U3 pin 5. The output of this latch (pin 5) is gated with ϕA and Unit Select in U4 to provide the Track 00 signal that is transmitted to the controller from U4 pin 27.

- f. The beginning of each diskette track is indicated by an Index pulse. The diskette rotates between a light source (LED) and a sensor (photo transistor). When the index hole in the diskette passes over the light source, light is detected by the sensor. The sensor output is amplified and transmitted to the controller as the Index pulse when the FDD is selected.

An index/sector separator can be provided on the FDD for use with hard-sectored diskettes. Proper operation of the ready function requires that the index pulses be separated in the FDD. The composite Index/Sector signal is applied to input pin 23 of U4. Adding jumper W8 provides the separated index and sector signals.

- g. The unit select function inhibits all command and status signals. The position of the FDD in the daisy-chain configuration is determined by the presence of the jumper W1, W2, W3, or W4. The FDD, as shipped, has W1 installed. Jumper W5 may be installed to cause the FDD to always be unit selected. This customer-installed jumper is useful for star configurations.

4.3.2 WRITE LOGIC

A write operation begins with a Write Enable command from the controller when the FDD is selected. This command simultaneously enables the write-data switching drivers within U4 (pins 9 and 10), turns on head center-tap drivers in U4 (pins 5 and 7) causing the center tap to go to approximately +12 volts, blocks the input to the read circuit by reverse-biasing diodes CR1 and CR2, and after a delay energizes the erase windings. Data applied to the Write Data input alternately switches a constant write current through the write drivers to the head windings. Low-current operation, used when writing on track 43 or greater, is selected by switching shunt resistor R28 into the write-current source. The source is contained within U4 and is factory-adjusted at R33.

4.3.3 READ LOGIC

Read operation is enabled when the Read/Write head is loaded on the diskette and Write Enable is inactive. With Write Enable inactive, the data-blocking diodes CR1 and CR2 are forward-biased by parallel 1K resistors in U4 (pins 5 and 7) pulling the head center tap to ground, and data sensed by the Read/Write head is fed to the LSI read-data circuit U2. The read signal from the diskette is in the form of a sine wave.

This analog signal is amplified within U2, filtered by R15, R16, L1, L2, C7, and C8 comprising a passive constant-phase filter, differentiated by R20 and C11 in conjunction with U2's active differentiator, and coupled to a comparator/logic circuit within U2 (a time-domain filter) to detect zero crossings and reject noise in the differentiated read signal. R8 and C4 are the timing components for a 1-us one-shot used in the time-domain filter. R9 and C5 are the timing components for the one-shot which establishes data pulse width. DC balance of the active differentiator by adjusting R32 allows symmetry of the read data to be optimized.

4.3.4 DISK DRIVE

Disk drive is accomplished by clamping the diskette between the cone assembly and a belt-driven spindle. The spindle is rotated at 360 r/min by the disk-drive motor.

4.3.5 READ/WRITE HEAD

The Read/Write head is in direct contact with the diskette during read or write operation. Since the head is rigidly mounted on the carriage assembly, head load is achieved by a solenoid-actuated bail allowing the head-load arm to force the diskette against the Read/Write head. The head surface is designed for maximum signal transfer to and from the magnetic surface of the diskette with minimum head/diskette wear. The tunnel-erase gap DC-erases the intertrack area to improve off-track signal-to-noise ratio and permit diskette interchange between units.

4.4 CONTROL AND DATA LINE CHARACTERISTICS

All signal lines must be terminated at the receiver with a characteristic impedance of 120 ohms, typically. Transmission is by 26 AWG (min.), 120-ohm flat cable or twisted pair (one twist per inch) with a maximum line length of 25 feet. Figure 5-1 shows the timing of typical operations.

4.4.1 LOGIC LEVELS

The following definitions will be used throughout this manual:

low = Logic 1, Active State Refers to the low-voltage condition
+0.4 VDC Max.

high = Logic 0, Inactive State Refers to the high-voltage condition
+2.4 VDC Min.

4.4.2 TRANSMITTER CHARACTERISTICS

The FDD uses the TTL7438 (quad 2-input buffer or driver) and LSI controller U4 to transmit all control and data signals. Each is capable of sinking a current of 25 mA with an output voltage of 0.4 volt.

4.4.3 LINE RECEIVER CHARACTERISTICS

The FDD uses the SN7400 family gates and their equivalent in the LSI controller IC U4 for line receivers. The input of each receiver is terminated in 120 ohms.

4.4.4 CONTROL AND DATA LINE FUNCTIONS

The signals that are exchanged are described in Table 4-2 and are shown relative to a point of origin in Figure 4-1.

TABLE 4-2. INPUT/OUTPUT LINES

SIGNAL	FUNCTION
<u>INPUT LINES</u>	
-STEP } *	<p>A 10-microsecond minimum, 3-millisecond maximum logic 1 level pulse on this line causes the head to move one track as determined by the direction line.</p>
-DIRECTION } *	<p>A logic 1 level on this line and step pulse causes the head to move one track inward toward the center of the diskette. A logic 0 level on this line and step pulse causes the head to move one track outward from the center of the diskette.</p>
-STEP IN } *	<p>A 10-microsecond minimum, 3-millisecond maximum logic 1 level pulse on this line causes the head to move one track inward toward the center of the diskette.</p>
-STEP OUT } *	<p>A 10-microsecond minimum, 3-millisecond maximum logic 1 level pulse on this line causes the head to move one track outward from the center of the diskette.</p>
-HEAD LOAD	<p>A logic 1 level on this line loads the diskette against the head through the use of a pressure pad on the opposing side of the diskette. The logic 1 level must be initiated 60 milliseconds prior to initiating a read or write operation to allow for head load settling time.</p> <p>For increased head and media life, this signal should be at a logic 0 whenever a data transfer operation is not in process or pending.</p>
-WRITE ENABLE	<p>To enable the FDD write driver, this line is held at a logic 1.</p> <p>To disable the FDD write driver and enable the FDD read circuitry, this line is held at logic 0. 850 microseconds minimum is required after a write operation before read data is stable.</p>

* As a customer-installed option, the STEP and DIRECTION lines--as the FDD is supplied from the factory--may be converted to STEP IN and STEP OUT by the installation of jumper W12.

TABLE 4-2. INPUT/OUTPUT LINES (CONT'D)

SIGNAL	FUNCTION
<u>INPUT LINES</u>	
-WRITE DATA	This line contains the composite double frequency coded write clock and data information to the FDD. The write clock and data pulses must be 250 nanoseconds $\pm 20\%$ in length and are true at the logic 1 level. Information to be recorded on the diskette is derived from the transition of each pulse from logic 1 to logic 0.
-LOW CURRENT	This line reduces write current for tracks 43 or greater. A logic 1 level reduces write current.
-UNIT SELECT	On this line a logic 1 level with W1, W2, W3, or W4 present enables the FDD interface.
<u>OUTPUT LINES</u>	
-READY	A logic 1 level indicates that the door is closed, a diskette is rotating, and that the FDD is selected.
-INDEX	This line gives an indication of the rotational position of the diskette by outputting a logic 1 pulse for every index hole of the diskette. The 1-millisecond pulse is generated by sensing the index hole in the diskette using a photo-optical technique.
-SECTOR	This line gives an indication of the rotational position of the hard-sector diskette by outputting a logic 1 pulse for every sector hole of the diskette. The 1-millisecond pulse is generated by sensing the sector holes with the same photo-optical assembly used for index. (W8 must be present.)
-TRACK 00	A logic 1 level indicates that the head is positioned over Track 00.
-WRITE PROTECT	Logic 1 level indicates that the write-protect slot on diskette is uncovered.
-READ DATA COMPOSITE	This line contains the unseparated data and clock information. A logic 1 level pulse of 250 ns corresponds to a data or clock bit read from the diskette.

5.1 DIAGRAMS

This section contains the printed circuit board documentation and related timing diagrams.

Figure 5-1 shows timing diagrams which illustrate signal/time relationships during read, write, step-in, and step-out operations. Figure 5-2 is the printed circuit board schematic, and Figure 5-3 contains the assembly drawing.

5.2 MAINTENANCE AIDS

5.2.1 INTRODUCTION

This section contains detailed information on the logic circuits used in the FDD. The logic consists of two types of circuits: discrete component and integrated circuits (IC). Integrated circuits are contained within a single chip and discrete component circuits contain individually identifiable resistors, capacitors, transistors, etc.

5.2.2 PHYSICAL DESCRIPTION (LOGIC)

All components are mounted on one side of the printed circuit board. The board is 8 X 11 in. (203.2 mm X 279.4 mm) and contains both IC and discrete component circuits.

5.2.3 USE OF RELATIVE LEVEL INDICATORS

The relative level indicator is a small triangle located on the input or output to a logic block. The presence or absence of this indicator indicates the conditions that are necessary to satisfy the function of the logic block. The presence of the triangle indicates a 1 logic level on that line is needed to satisfy the function. The absence of the triangle indicates a logical 0 is needed to satisfy the function.

The relative level indicator depicts the occurrence of inversion. Figure 5-4 shows some representative examples of the relative level indicator being used in this manner.

5.2.4 INTEGRATED CIRCUITS

Figure 5-5 shows an example of a schematic block and the information that it contains. The first line gives the function symbol which identifies the logic function that the block performs. Refer to Figure 5-6 for a summary of function symbols. The second line gives the CDC element number. The third line on the schematic block gives the circuit reference designation.

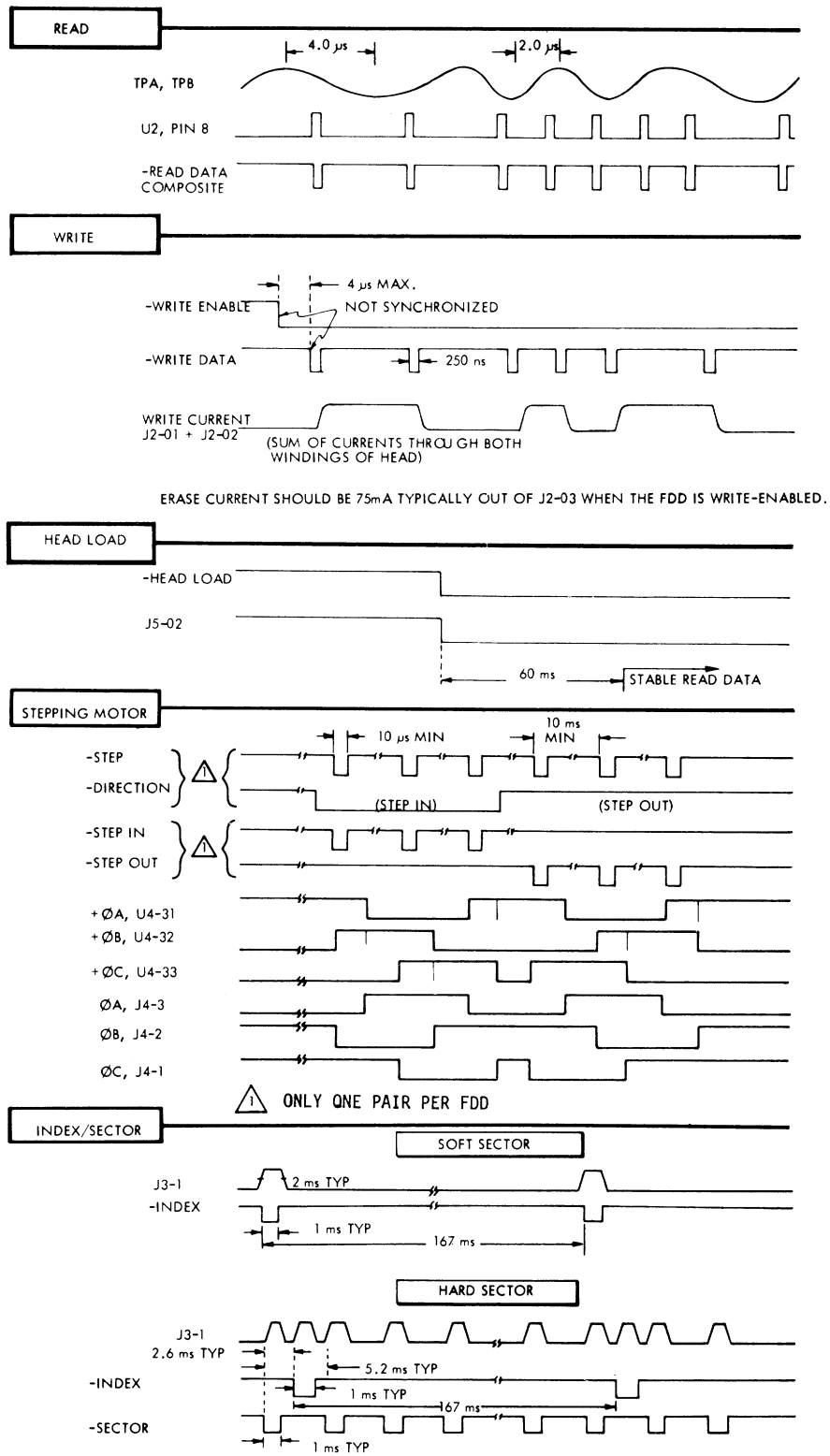

2266a

FIGURE 5-1. TIMING

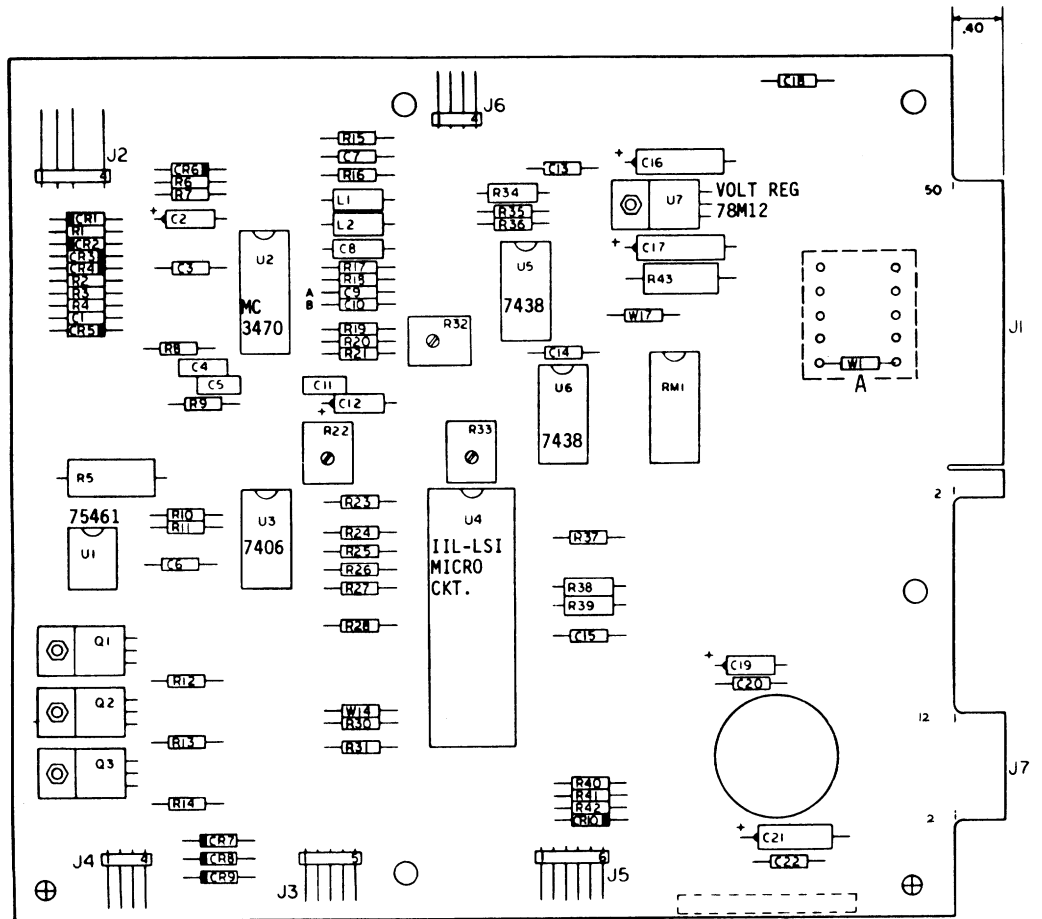

TRANSISTORS
 Q1, Q2, Q3 - T1P120

DIODES
 CR1, CR2, CR3, CR4, CR5 - 1N914A
 CR6, CR7, CR8, CR9, CR10 - 1N4001

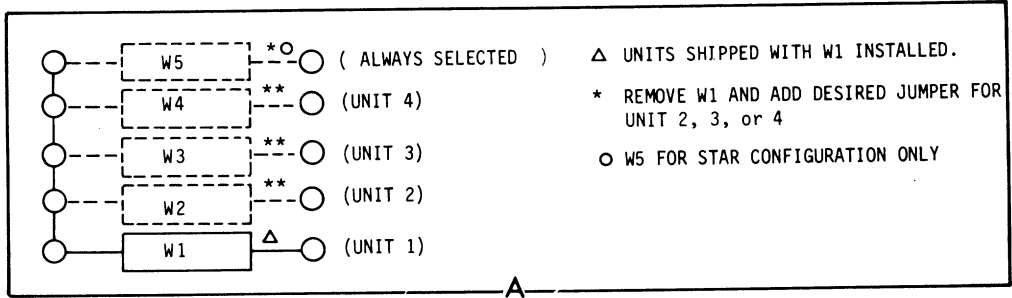

Z267a

FIGURE 5-3. ASSEMBLY AND PARTS LIST

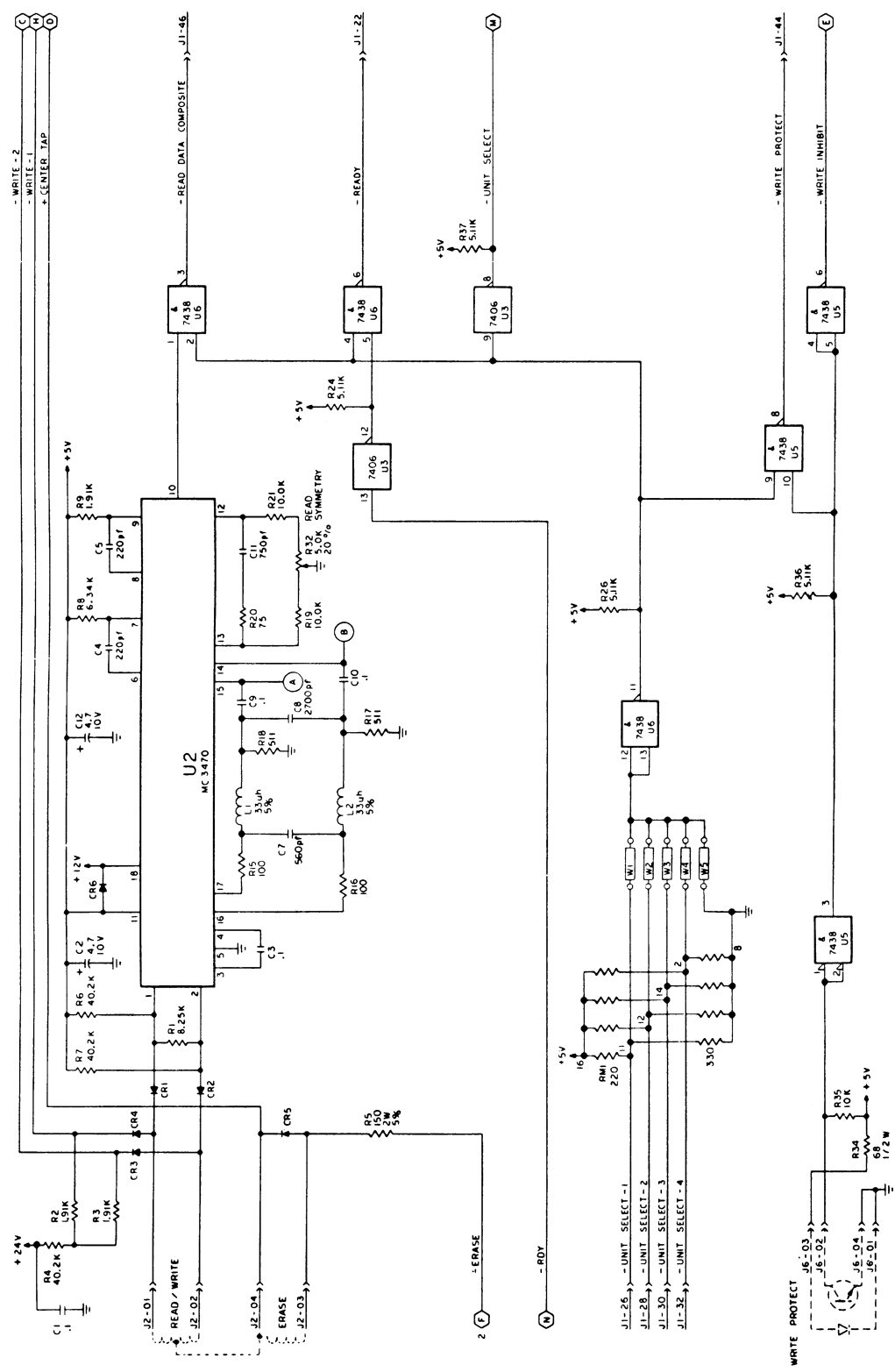

FIGURE 5-2. SCHEMATIC (SHEET 2 OF 2)

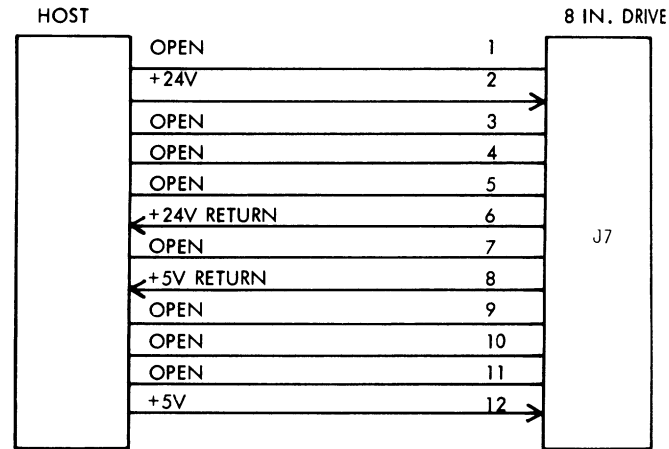
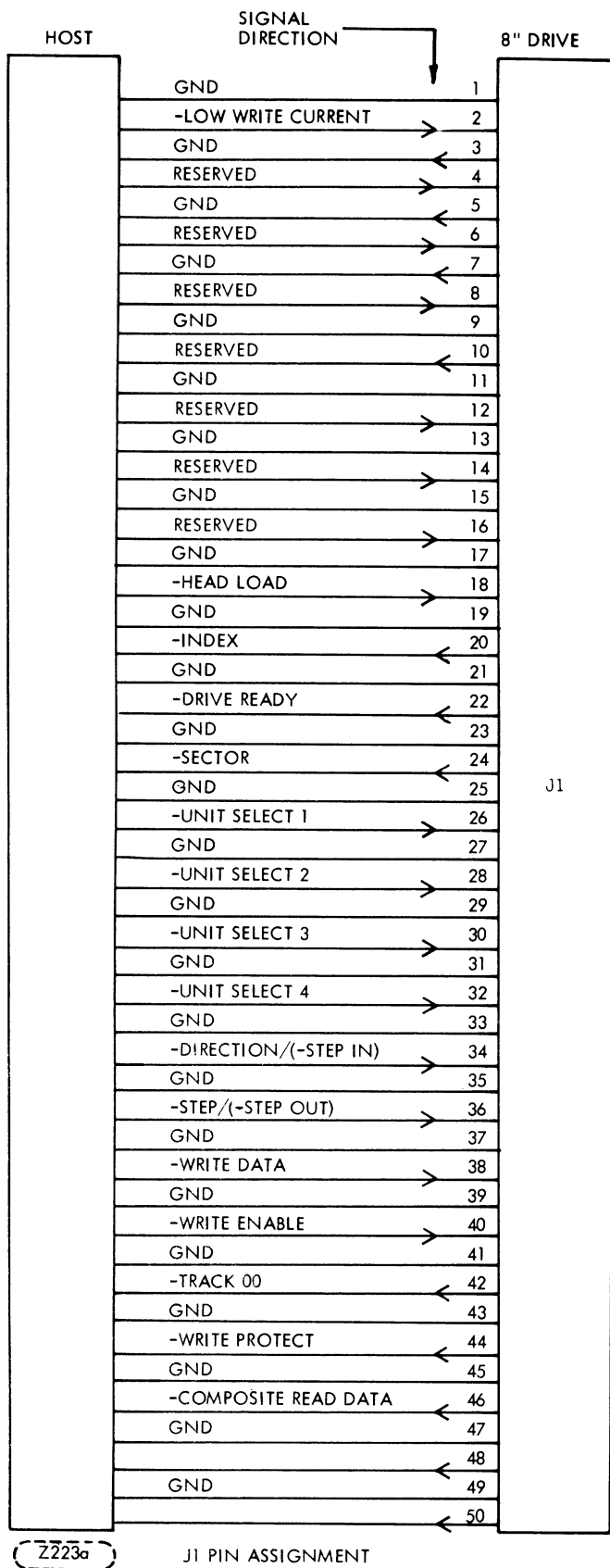

FIGURE 5-4. J1 AND J7 PIN ASSIGNMENTS

6.1 INTRODUCTION

This section contains the instructions required to maintain the FDD. The information is provided in the form of preventive maintenance, troubleshooting, and corrective maintenance.

6.2 MAINTENANCE TOOLS

The special tools (or equivalent) required to maintain an FDD are as follows:

<u>DESCRIPTION</u>	<u>CDC PART NUMBER</u>
Alignment Diskette (Optional)	Model 421-51W

The standard tools required to maintain the FDD are as follows:

- Socket Wrenches
Sizes: 5/16" (7.94mm), 1/4" (6.35mm), 3/16" (4.76mm), 11/32" (8.73mm)
- Allen Wrenches
Sizes: 0.050" (1.27mm), 1/16" (1.59mm), 5/64" (1.98mm), 7/64" (2.78mm)
- Oscilloscope, Tektronix 335, or equivalent.
- Feeler Gauges, wire
Sizes: 0.030" (0.762mm), 0.058" (1.47mm), 0.060" (1.52mm), 0.062" (1.58mm), 0.079" (2.01mm)
- Feeler Gauge, Shim: 0.072" (1.83 mm), 0.020" (0.508 mm)
0.010" (0.254 mm), 0.005" (0.127 mm)

6.3 PREVENTIVE MAINTENANCE

The head load pad should be inspected after 650 hours of head-load time. If pad is worn, dirty, torn, or loose it should be replaced. (See paragraph 6.7.4).

6.4 HEAD CLEANING

On occasions the Read/Write head may require cleaning. If this situation occurs clean head as follows:

CAUTION

Do not smoke while cleaning. Do not touch a head surface with fingers. Do not leave residue or lint on the head surfaces. Residual particles can result in a scored disk and/or loss of a head.

Do not raise head-load arm to the 90-degree position and then release it; damage to the load-arm spring and/or to the head (core and ceramics) could result.

- a. Use lint-free cloth to lightly drybuff head surface. Cleaning is completed if deposits are removed.
- b. If oxide deposits were not removed in step (a), dampen (do not soak) cloth with cleaning solution (91% isopropyl alcohol) and wipe head surface. Finish by lightly dry buffing again to ensure that the head is dry and no alcohol residue is left.

6.5 TROUBLESHOOTING

An improperly adjusted FDD may exhibit symptoms of one that has a malfunction; therefore, the Adjustment Procedures (paragraph 6.6) should be performed before assuming that the unit has failed. Refer to Figure 6-1 for test points to be used in further troubleshooting. Before troubleshooting is started, check all DC supply voltages.

6.5.1 DC VOLTAGE AND SIGNAL

- a. Input power should be +5 VDC $\pm 5\%$ and +24 VDC $\pm 10\%$ measured at the input to the FDD (refer to paragraph 3.4.2).
- b. The signals should conform to the various diagrams and waveforms as shown in Figures 5-1, 6-1, 6-2, 6-3 and 6-4.

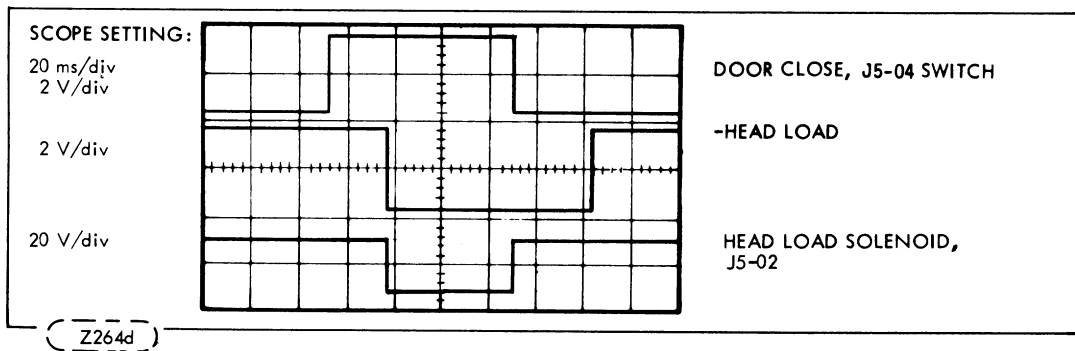

FIGURE 6-1. -HEAD LOAD AND DOOR INTERLOCK SWITCH

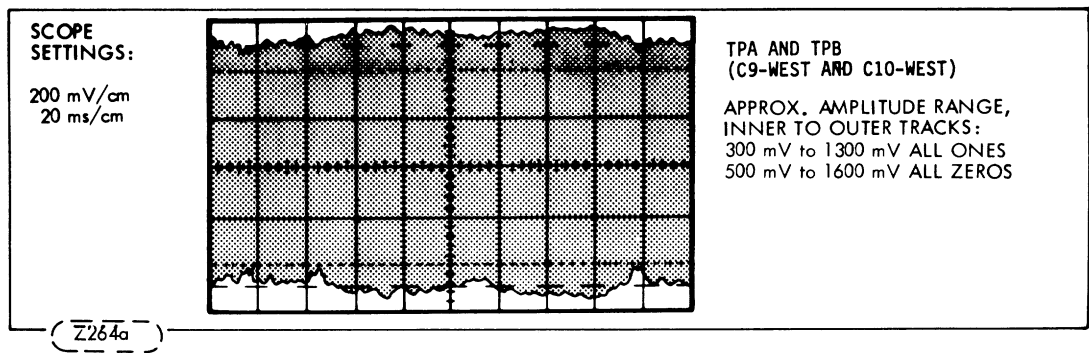

FIGURE 6-2. DIFFERENTIAL READ SIGNAL FOR ENTIRE TRACK

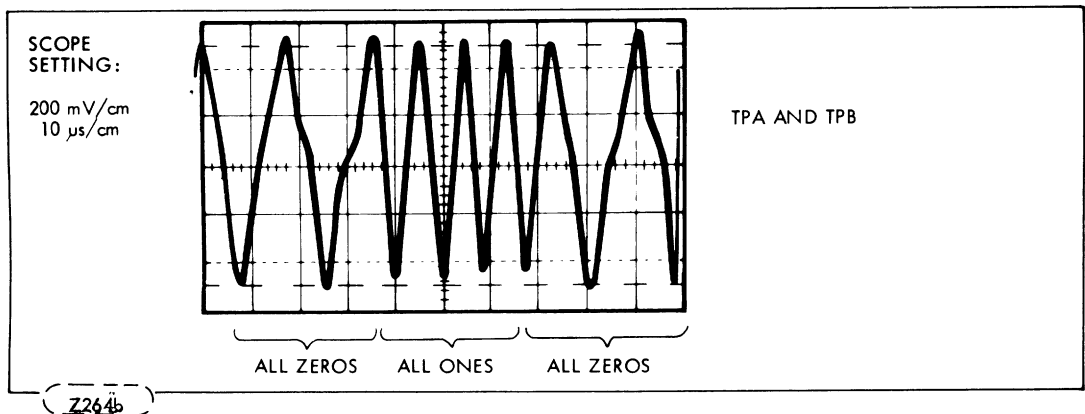

FIGURE 6-3. DIFFERENTIAL READ SIGNAL FOR PORTION OF OUTER TRACK

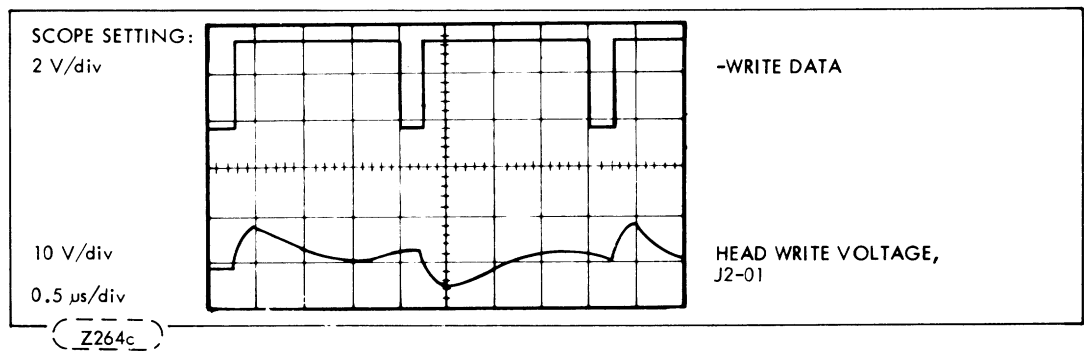

FIGURE 6-4. WRITE DATA AND HEAD WRITE VOLTAGE FOR OUTER TRACK

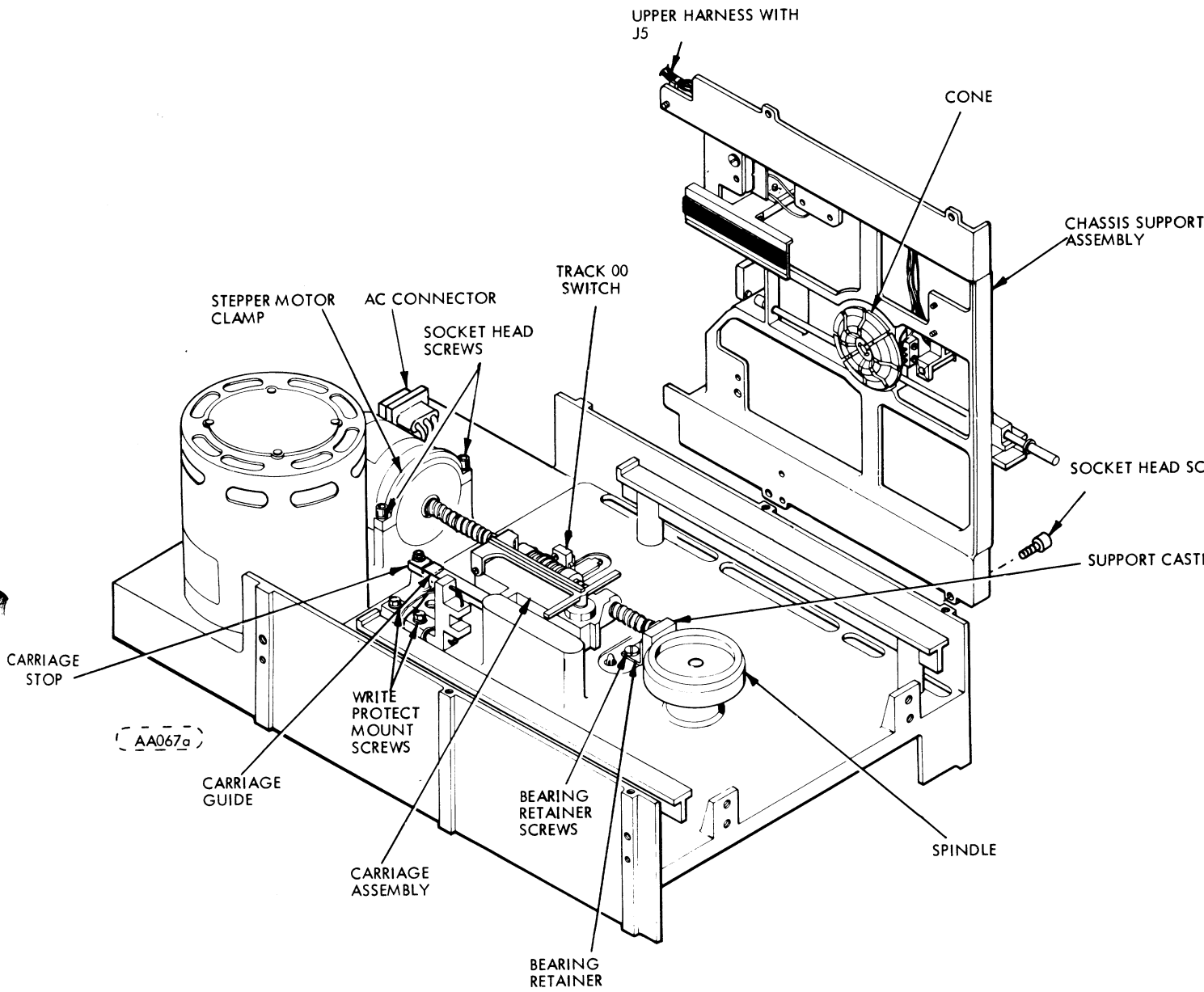
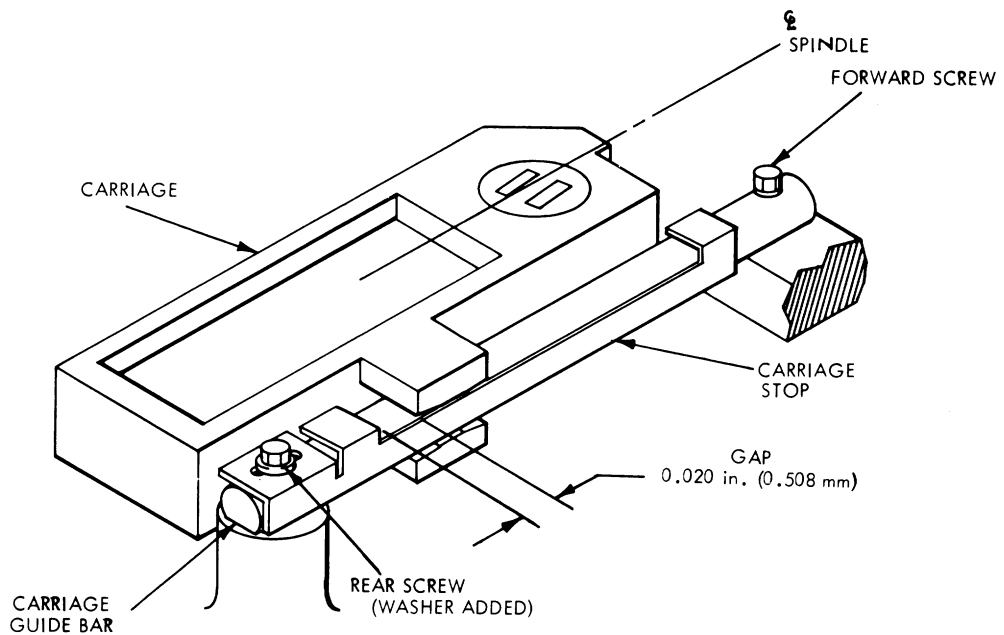

FIGURE 6-5. BASE AND CHASSIS SUPPORT ASSEMBLY



(X327a)

FIGURE 6-6. CARRIAGE-STOP ADJUSTMENT

- f. All scope settings are to remain as defined in the original setup in step "d", but it may be necessary to slightly adjust the sync. Seek to track 00 then seek to track 1 and perform a read. While observing the signal on the scope, remove and reinsert the diskette three times.

After each insertion, verify that the change in the time from write splice to leading edge of index is less than 50 μs . If the change is greater than 50 μs , the cone and spindle must be aligned or replaced (see Section 6.6.7) and steps "a" through "f" repeated.

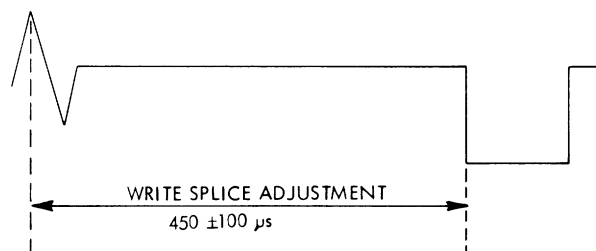

(AA036c)

FIGURE 6-7. WRITE SPLICE BIT TO INDEX TIMING

6.6.3 ACTUATOR ALIGNMENT (DISKETTE)

The Alignment Diskette is used to perform this procedure.

- a. Alignment Diskette 421-51W shall be preconditioned by allowing it to reach room temperature for one hour.
- b. Install the alignment diskette.

CAUTION

The alignment diskette is for read only.
Extreme caution should be used to assure
this diskette is not written on.

- c. Step to track 38 and perform a read. (No data is recorded on track 38. The tester or system requirements should be noted; refer to tester or system instructions for operation.)
- d. Connect Channel 1 of scope to TPA on the PWA and Channel 2 to TPB on the PWA.
- e. Connect the external sync probe to index at Index, J1-20 on PWA.
- f. Set up the scope as follows:

Channel 1: volts/div to: 0.1 volts/div
Channel 2: volts/div to: 0.1 volts/div (inverted)
Channel 1: input to: AC
Channel 2: inputs to: AC

Vertical Mode to: Add
Slope (Sync) to: Positive
Trigger Source to: External
Trigger Coupling to: Low Frequency (High Frequency Reject)
Trigger Mode to: Normal
Time Base to: 20 ms/div

NOTE

Scope trace after trigger level is adjusted for repetitive trace should display an envelope of data "Cateyes" consisting of two lobes (refer to Figure 6-8). If no such pattern can be displayed, manually turn the stepper motor shaft extending from the rear of the stepper motor one-quarter turn either way to locate pattern. The amplitude of the smaller lobe must exceed 200 mV p-p. Then proceed to step "h".

- g. Change the volts/div of Channel 1 and Channel 2 to 0.02 volts/div. Move the trace on the scope (Position Knob) up until the bottom of the two lobes are setting approximately on the base line (refer to Figure 6-8). For an acceptably aligned unit, the voltage ratio of the smaller lobe to the larger lobe should exceed 80%.
- h. If not in alignment, loosen the stepper motor clamp mounting screws to where a gap exists between the clamp and casting (see Figure 6-9) and slowly rotate the stepper motor to adjust the amplitude until the amplitude of both lobes is the same, that is, the difference between the bottoms of both lobes is less than 5 mV.

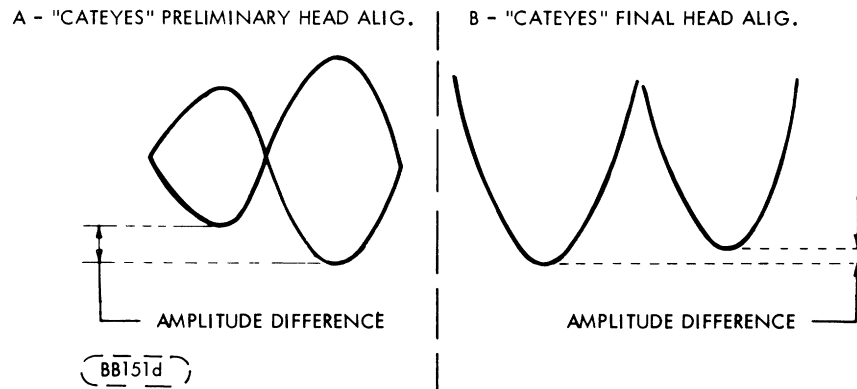

FIGURE 6-8. HEAD ALIGNMENT AMPLITUDE

- i. Tighten the stepper motor clamp. Return to track 00, then seek back to track 38. Verify that the 5 mV specification is still met. If the specification is not met, readjust the stepper motor, return to zero and seek back to track 38. Repeat the adjustment until the 5 mV specification is met.
- j. Remove alignment diskette.
- k. Perform Track 00 Switch Adjustment Paragraph 6.6.9.
- l. Perform Stop Gauge Adjustment per Paragraph 6.6.1.
- m. Recheck all adjustments made in this procedure and repeat all steps having out-of-tolerance indications.

6.6.4 PUSH-ROD TRAVEL ADJUSTMENT

This procedure must be performed whenever chassis support (Figure 6-9) is removed and replaced.

- a. With front panel door closed, verify that a gap exists between the retaining ring and the disk load bushing of approximately 0.030 inch (0.762 mm) (refer to Figure 6-9). Perform steps b and c if out of adjustment.
- b. Back-off the Door Interlock Switch Adjustment set screw.
- c. Adjust disk load arm set screw (Figure 6-9) until gap is approximately 0.030 in. (0.762 mm), with door closed.
- d. Proceed to Door Interlock Switch Adjustment (paragraph 6.6.5)

6.6.5 DOOR-INTERLOCK SWITCH ADJUSTMENT

This procedure must be performed whenever the Push-Rod Travel Adjustment procedure is performed.

- a. Verify that interlock switch closes (when closing the door) prior to the door latching. Perform step (b) if switch and door are out of sync.
- b. With door closed, adjust set-screw at end of disk load arm (Figure 6-9) while holding door closed against metal stop. Adjust set-screw until micro-switch is almost adjusted flush to top of switch case. This ensures that as the nylon tips on the push-rod wear down, the switch will still close.

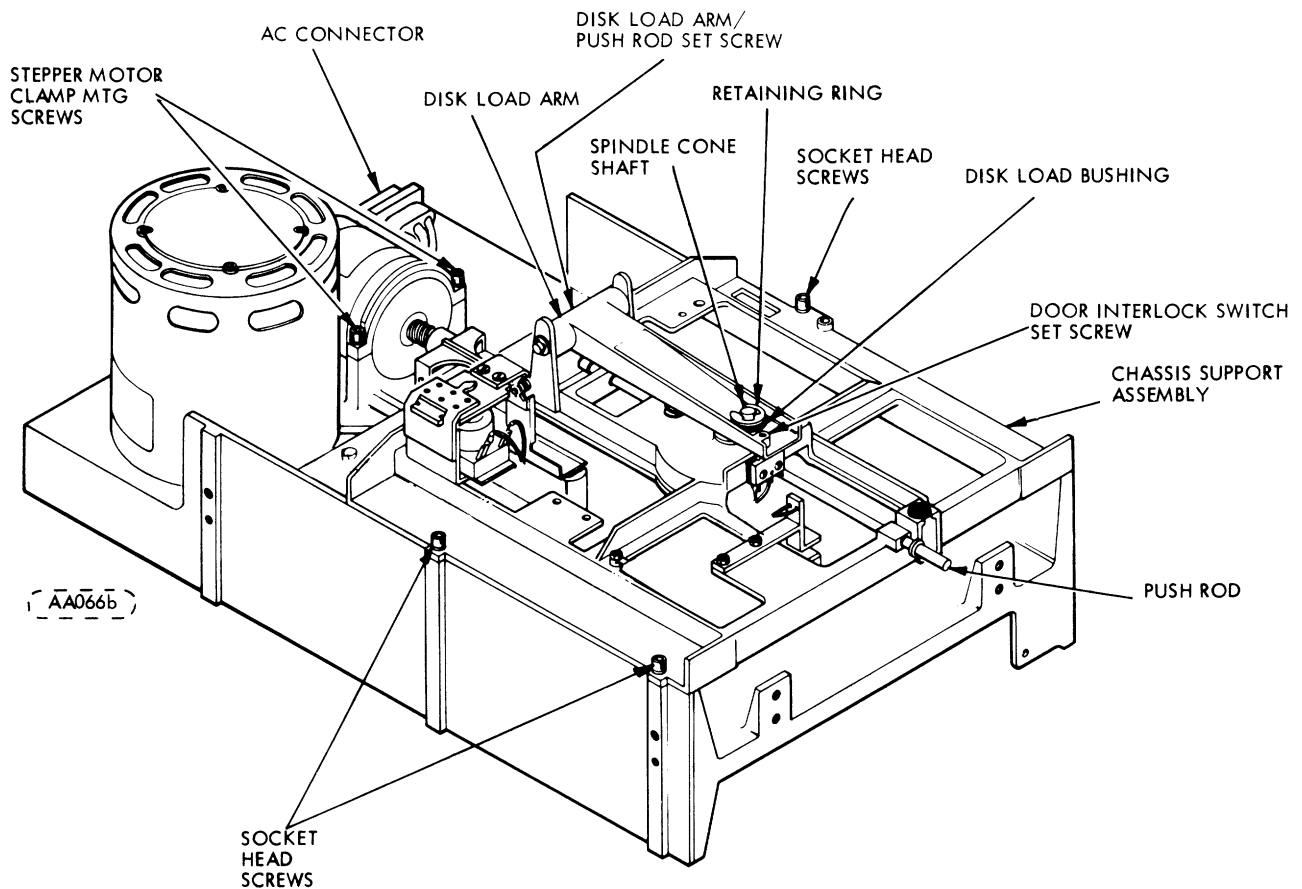

FIGURE 6-9. CHASSIS BASE ASSEMBLY

6.6.6 DISK-LOAD BAIL ADJUSTMENT

This procedure must be performed whenever the solenoid or bail are removed or the screw holding the bail becomes loose.

- a. Place a 0.010 in. (0.254 mm) feeler gauge on boss of bottom support casting underneath bail.
- b. Energize solenoid.
- c. Loosen mounting screw on bail (Figure 6-10).
- d. Adjust Bail so the foam pad touches the feeler gauge.
- e. Tighten mounting screw.

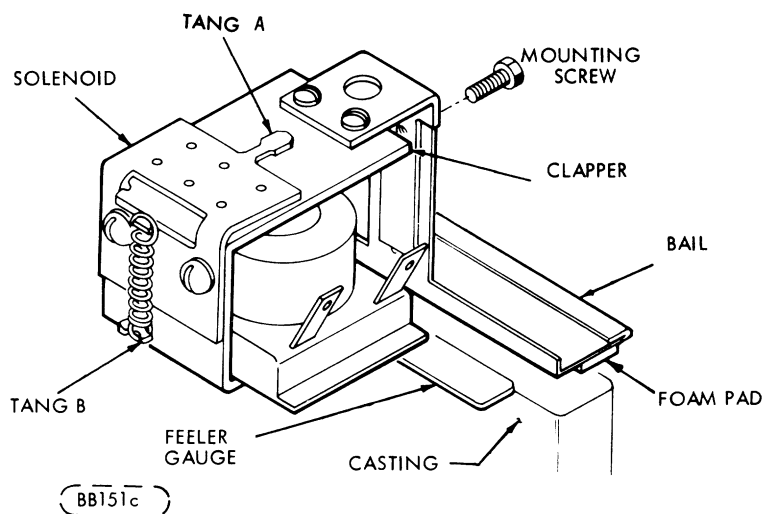

FIGURE 6-10. DISK LOAD SOLENOID

6.6.7 SPINDLE AND CONE ADJUSTMENT

This procedure must be performed whenever the spindle and cone are out of alignment or whenever the actuator assembly is removed or replaced.

- a. Loosen chassis support assembly (Figure 6-9).
- b. Position chassis assembly by pushing down on the spindle cone shaft so cone seats in the spindle (Figure 6-11).
- c. Slowly close door without spindle turning. Spindle top surface and cone spindle contact surface must meet at the same time on the full circumference of the spindle (see Figure 6-11).
- d. Complete door closing slowly. Visually verify that all segments on the cone that can be seen are fully seated in the spindle. Slowly rotate spindle and verify that all cone segments are seated and that the segments do not seat as the spindle is rotated as evidenced by a "clicking" sound or observing the segments seating.
- e. Repeat fully opening and closing door four times. Verify that after each closing all cone segments are fully closed. Verify that the load arm does not bind when door is opened and closed.
- f. Secure socket head screws (Figure 6-9) and again recheck steps "c" through "e".

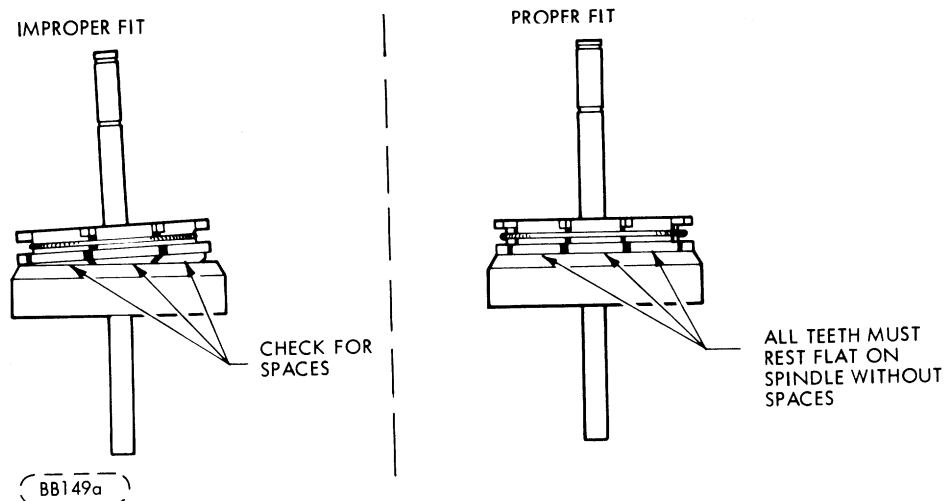

FIGURE 6-11. SPINDLE AND CONE

6.6.8 WRITE PROTECT ASSEMBLY ADJUSTMENT (WHERE APPLICABLE)

This adjustment will be required whenever the unit is disassembled, or a different style diskette is utilized in the unit.

- a. With a Write-Protected diskette installed in the unit (Write-Protect slot uncovered), monitor U5 pin 4/R36-East for the WRITE PROTECT signal. A continuous logically high signal will be present whenever the Write-Protect assembly is properly adjusted. A logically low signal will appear if not properly adjusted.
- b. To adjust, loosen the two hex-head screws holding the sensor mount in place. With the front panel door open, push down on the disk load arm (Figure 6-9) to insure that the disk is in the loaded position (Figure 6-10). At the same time, grasp the end of the envelope and move from side-to-side, and forward and backward while observing the WRITE-PROTECT signal at U5 pin 4/R36-East. Adjust the mount until the WRITE-PROTECT signal is present for any position of the envelope.
- c. Tighten the mount screws, and re-check to verify signal under all conditions of envelope position.

6.6.9 TRACK '00' SWITCH ADJUSTMENT

Perform the procedure given below whenever the Track 00 switch has been replaced, or the device fails to give current Track 00 indication, or if the head has been realigned.

- a. Step the Read/Write head out to Track 01.
- b. Place a 0.010 (0.254 mm) feeler gauge between the carriage assembly and Track 00 switch.
- c. Verify that the Track 00 switch closes by observing a low level at terminal J3-2 on the Component Board Assembly.
- d. If the low level does not occur, loosen the Track 00 switch-bracket mount screw and rotate the switch bracket forward until the low level occurs.
- e. Place a 0.005 (0.127 mm) feeler gauge between the carriage assembly and Track 00 switch after removing the 0.010 (0.254 mm) feeler gauge.
- f. Verify that the Track 00 switch remains open by observing a high level at terminal J3-2 on the Component Board Assembly.
- g. If the high level does not occur, loosen the Track 00 switch-bracket mount screw and rotate the switch bracket backward until the high level occurs.
- h. Repeat "b" through "g".

6.7 REMOVAL AND REPLACEMENT PROCEDURES

The following procedures give the proper sequence for removal and replacement of major assemblies. To avoid damage to parts, the procedure must be performed in sequence.

6.7.1 PRINTED CIRCUIT BOARD (PWA)

- a. Disconnect I/O Cable from J1.
- b. Disconnect DC power cable from J7, and AC power from FDD.
- c. Disconnect harnesses from connectors on printed-circuit board.
- d. Remove two screws from printed-circuit board adjacent to connector J1 (Figure 6-12).
- e. Remove PWA by detaching it from the two push-in clips shown in Figure 6-12.
- f. To replace printed-circuit board, push clips through printed-circuit board.
- g. Replace two screws adjacent to connector J1.
- h. Reconnect harnesses, I/O cable, DC power cable, and AC power cable.
- i. Perform Burst-to-Index Check and adjust if necessary (paragraph 6.6.2).

6.7.2 ACTUATOR ASSEMBLY

- a. Open front-panel door.
- b. Disconnect harness from J2 and J4 on printed-circuit board (see Figure 6-1).
- c. Remove four (4) socket-head screws securing chassis support (Figure 6-9).
- d. Slide chassis support back far enough to clear push rod (Figure 6-9) of front panel and lift support clear of chassis.
- e. Remove two (2) screws securing bearing retainer (Figure 6-5).
- f. Remove stepper-motor clamp by removing two socket-head screws (Figure 6-5). Remove Cable Clamp.
- g. Carefully slide actuator assembly (stepper motor, actuator, and bearings at the end of stepper shaft) straight out toward the rear of the FDD until unit is clear of the casting.
- h. To replace actuator assembly, slip bearings into support casting, Figure 6-5. (Assure carriage assembly is fitted on carriage guide.)

CAUTION

The wavy spring washer between the two bearings can prevent the bearings from being inserted into the support casting if the washer has slipped off-center and protrudes beyond the circumference of the bearings. If this happens, loosen the retainer screw on the end of the shaft so the bearings can separate and the washer can be repositioned. The screw must be retightened after the bearings are successfully inserted.

- j. Replace stepper-motor clamp and two socket head screws (Figure 6-5).
- k. Secure the bearing retainer by replacing the two bearing retainer screws (Figure 6-5).

CAUTION

The bearing retainer clamp should have an included angle of approximately 92° between the base and side. When base is securely fastened to chassis, this will assure proper tension on bearings. If a gap exists between bearing and retainer or if bearing is being bound up by retainer, this angle must be checked.

- l. Perform Actuator Alignment Procedure, (paragraph 6.6.3).
- m. Perform Spindle and Cone Adjustment, (paragraph 6.6.7).
- n. Perform Push-Rod Travel Adjustment, (paragraph 6.6.4).

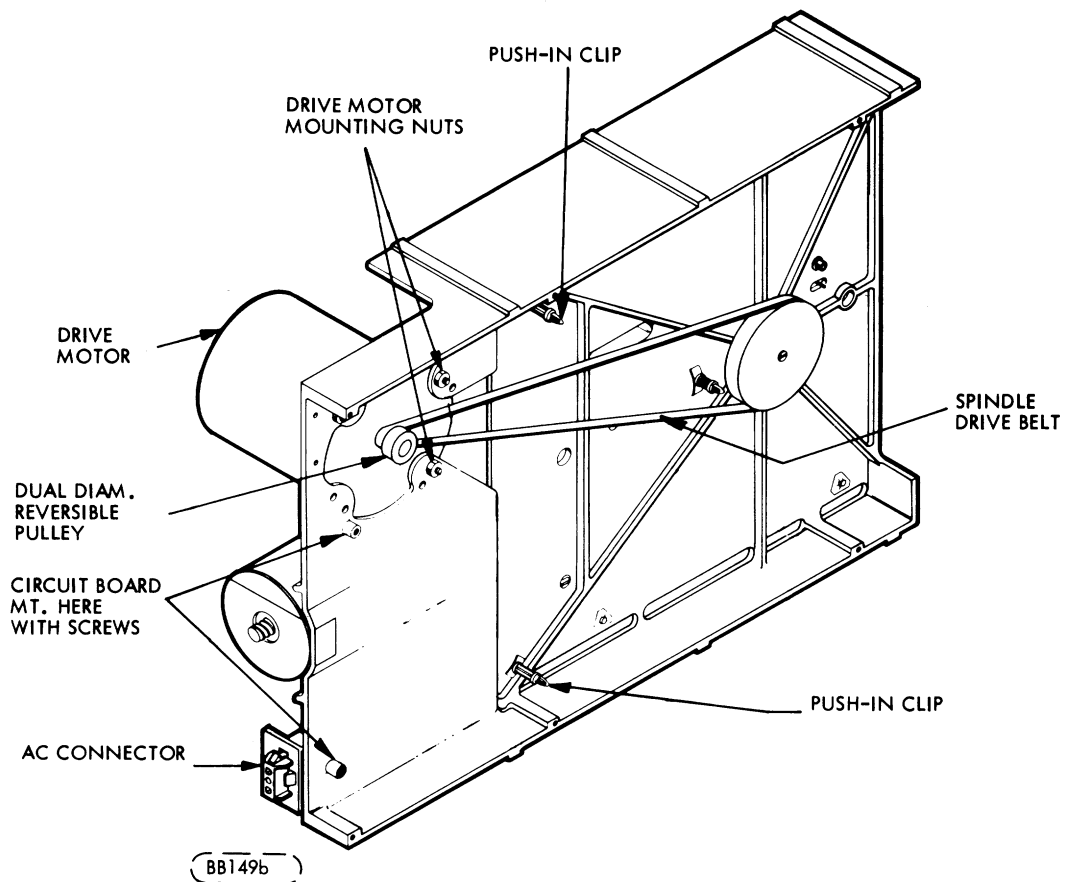

FIGURE 6-12. BASE CASTING ASSEMBLY

6.7.3 DRIVE-MOTOR ASSEMBLY

- a. Perform removal procedure for printed-circuit board (paragraph 6.7.1).
- b. Remove screws securing drive-motor cable clamps.
- c. Remove AC connector from bracket. (Figure 6-12)
- d. Remove spindle drive belt (Figure 6-12).
- e. Remove three (3) nuts securing drive motor (Figure 6-12).
- f. Remove drive-motor assembly (drive motor, capacitor, and AC connector).
- g. To replace drive-motor assembly perform, in reverse order, Steps f through a substituting the word "replace" for the word "remove."

6.7.4 HEAD-LOAD-PAD REPLACEMENT

CAUTION

Do not raise the head-load arm to the 90-degree position and then release it; damage to the load-arm spring and/or to the head (core and ceramics) could result.

- a. Remove power from the unit.
- b. Move the carriage assembly to its rear most position (toward the stepper motor) by turning the aft part of the stepper motor shaft (Figure 6-13). This will provide clearance for lifting the head load arm.
- c. Lift the head load arm until the head load pad is visible (see Figure 6-13).
- d. Loosen clamping screw holding rim of head-load pad.
- e. Insert screw driver and rotate head-load pad so flattened side will clear clamping screw.
- f. Remove Pad Holder Assembly.
- g. Insert new Assembly, with flat side toward clamping screw.
- h. Assuring that head load pad is fully seated, rotate pad 180 degrees.
- i. Tighten clamping screw to hold pad in place.
- j. Lower arm gently onto head.

6.7.5 SOLENOID REPLACEMENT AND TANG ADJUSTMENT

This procedure must be performed whenever the solenoid is out of alignment or whenever the solenoid assembly is replaced.

- a. Place the tapered end of a flat-head screw driver between Tang A and solenoid clapper. (See Figure 6-10.)
- b. Gently bend the tang upward with the screwdriver.
- c. Using a 0.060-in. (1.52 mm) wire feeler gauge, insert the feeler gauge in the gap between the underside of the clapper and the coil core. (See Figure 6-14.)
- d. If unable to insert 0.060-in. (1.52 mm) wire feeler gauge, continue to gently bend tang upward until feeler gauge can be inserted.
- e. Next, attempt to insert a 0.062-in. (1.58 mm) wire feeler gauge between the underside of the clapper and the coil.
- f. If this gauge can be inserted, bend tang down until a 0.062-in. (1.58 mm) feeler gauge will not insert in the gap between the clapper and the coil core.

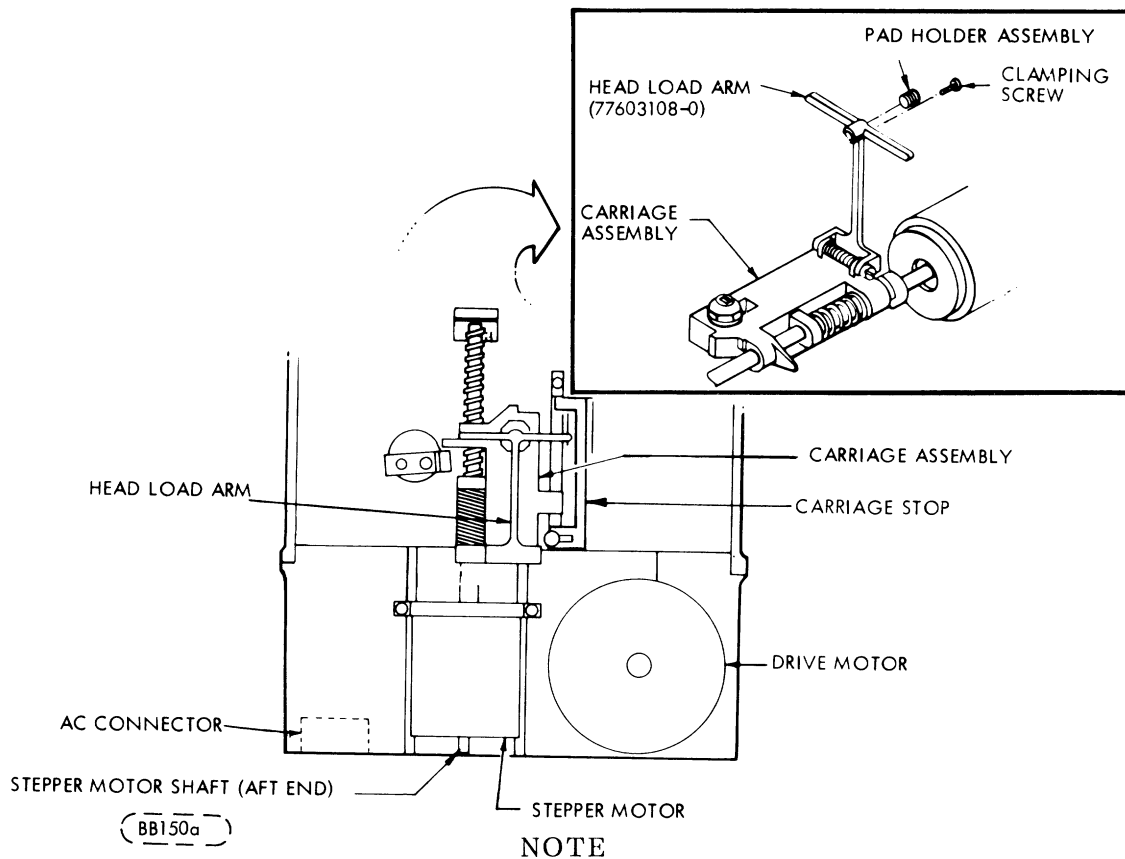

FIGURE 6-13. HEAD-LOAD-PAD REPLACEMENT ILLUSTRATION

- g. Insert a 0.058-in. (1.47 mm) wire feeler gauge in the gap between the underside of the clapper and the coil core.
- h. If 0.058-in. (1.47 mm) feeler gauge will not fit, bend the tang up slightly.
- i. Continue checking with the 0.062-in. (1.58 mm) wire gauge feeler and 0.058-in. (1.47 mm) wire gauge until the following condition is achieved:
 1. 0.062-in. (1.58 mm) feeler gauge will not pass between tang and clapper;
 2. 0.058-in. (1.47 mm) feeler gauge passes freely between tang and clapper.
- j. Check the spring adjustment by gently pressing down on the clapper until the 0.060 in. (1.52 mm) ± 0.002 -in. (0.051 mm) gap is closed.
- k. Allow the clapper to rise slowly and release.
- l. The clapper should be in contact with the tang.
- m. If not, bend the lower tang B, Figure 6-10, downward gently.
- n. Recheck that the clapper rises and perform Step "m" until the clapper and tang make contact.
- o. Check the bail adjustment per paragraph 6.6.6.

6.7.6 CARRIAGE AND/OR STEPPER MOTOR REPLACEMENT

The carriage and stepper motor are to be replaced as one assembly, being factory assembled and tested only. Refer to Section 6.7.2.

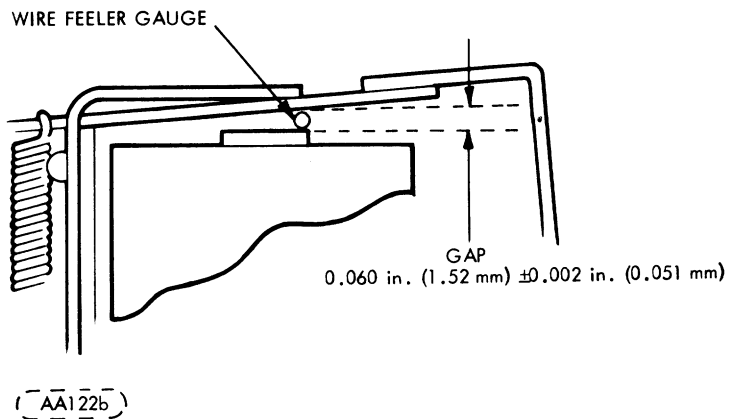
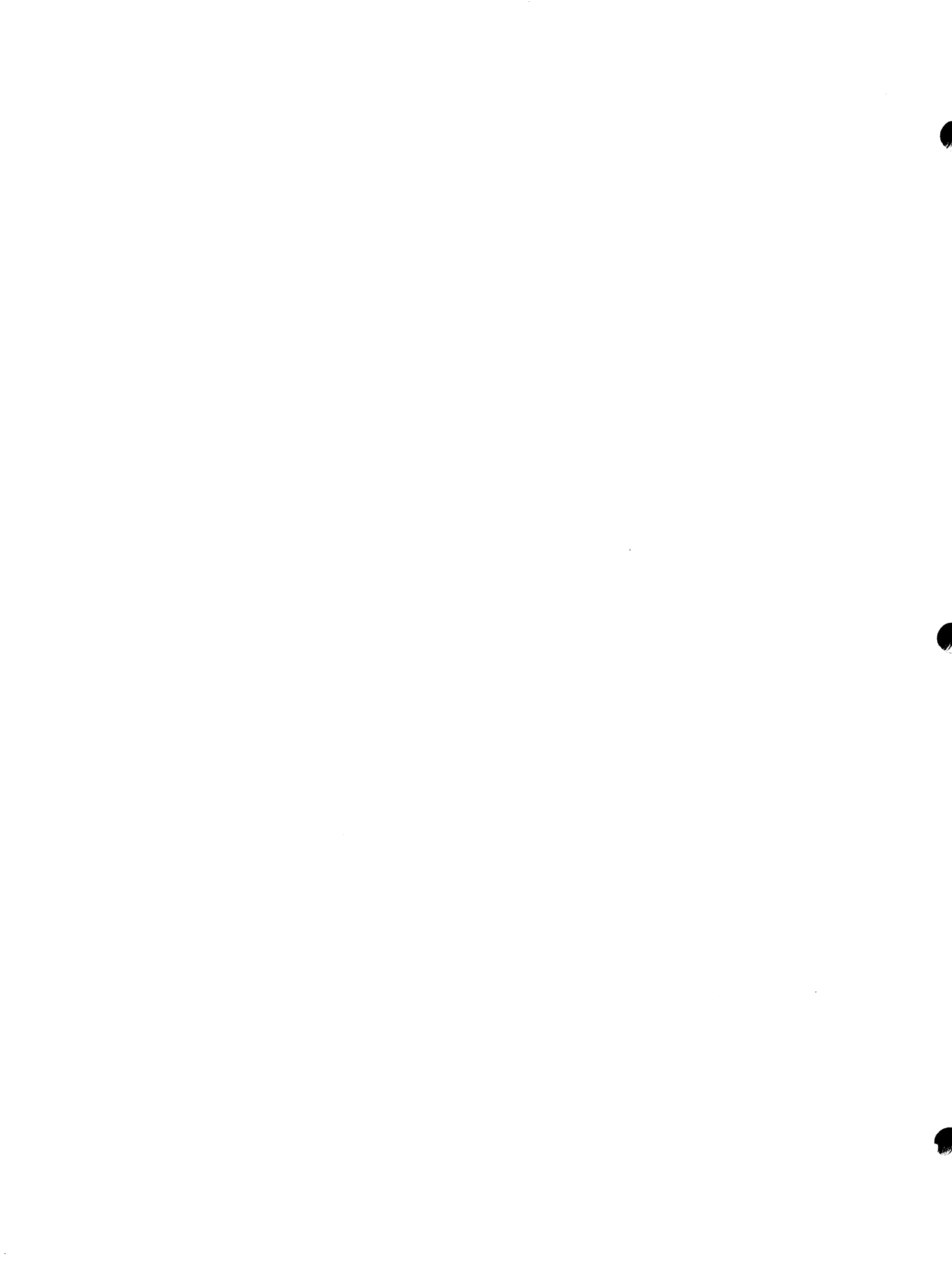

FIGURE 6-14. SOLENOID ADJUSTMENT



7.1 INTRODUCTION

The following paragraphs contain the wire lists for the Upper Harness Assembly, Lower Harness Assembly and the Stepper Motor.

7.2 UPPER HARNESS ASSEMBLIES

<u>Wire Color</u>	<u>Origin</u>	<u>Destination</u>	<u>Approximate Length Inches</u>
Red	Solenoid-A	J5-5	11.0" (279.4mm)
Black	Solenoid-B	J5-2	11.0" (279.4mm)
Orange	Interlock Common	J5-6	13.5" (342.9mm)
White	Interlock N. O.	J5-4	13.5" (342.9mm)
Blue	LED Cathode	J5-1	13.5" (342.9mm)
Yellow	LED Anode	J5-3	13.5" (342.9mm)

7.3 LOWER HARNESS ASSEMBLY

<u>Wire Color</u>	<u>Origin</u>	<u>Destination</u>	<u>Approximate Length Inches</u>
Black	Track 0 Common	J3-5	20.0" (508.0mm)
Red	Track 0 N. C.	J3-3	20.0" (508.0mm)
White	Track 0 N. O.	J3-2	20.0" (508.0mm)
Blue	Photo Transistor Emitter	J3-4	9.0" (228.6mm)
Yellow	Photo Transistor Collector	J3-1	9.0" (228.6mm)

7.4 STEPPER MOTOR

<u>Wire Color</u>	<u>Origin</u>	<u>Destination</u>	<u>Approximate Length Inches</u>
Brown	Stepper Motor	J4-1	13.0" (330.2mm)
Red	Stepper Motor	J4-2	13.0" (330.2mm)
Orange	Stepper Motor	J4-3	13.0" (330.2mm)
Black	Stepper Motor	J4-4	13.0" (330.2mm)

7.5 WRITE PROTECT

<u>Wire Color</u>	<u>Origin</u>	<u>Destination</u>	<u>Approximate Length Inches</u>
Blue	LED Cathode	J6-1	20.0" (508.0mm)
Red	Phototransistor Collector	J6-2	20.0" (508.0mm)
Green	LED Anode	J6-3	20.0" (508.0mm)
White	Phototransistor Emitter	J6-4	20.0" (508.0mm)



PARTS DATA

8.1 INTRODUCTION

This section contains an illustrated parts breakdown that describes and illustrates all variations of the Flexible Disk Drive (FDD). In general, parts are in disassembly sequence but do not necessarily indicate the maximum recommended disassembly of parts in the field.

8.2 ILLUSTRATIONS

Item numbers within a circle (1) indicate an assembly (group of parts). Item numbers without a circle, 1, indicate a single part; a group of parts that are pinned or press fitted together; or a group of parts which is normally replaced as an assembly.

8.3 PARTS LISTS

In addition to the accompanying parts list on each illustration, two additional Parts Lists are available; the Top-Down Assembly/Component Parts List and the Cross Reference Index. Instruction for the use of all Parts lists in paragraph 8.6.

8.4 TOP MECHANICAL AND ASSEMBLY LOCATION

In conjunction with Table 8-1, Figure 8-1 serves two purposes;

1. When used with Table 8-1, it identifies all unique parts and assemblies for each FDD variation.
2. It identifies by sheet location where all major assemblies are broken down.

8.4.1 TOP MECHANICAL ASSEMBLY (TMA)

To determine what parts are used on a particular model, find the applicable model in Table 8-1. The corresponding item number represents the last three digits of the TMA number. Example: Model BR803N, TMA number 75744013. The item numbers at the top of Table 8-1 corresponds with the item numbers in Figure 8-1. All parts and assemblies that apply will be identified with an 'X' ('0' means not applicable).

8.5 REPLACEMENT PARTS

When ordering replacement parts for the FDD, the inclusion of the Model designation and the figure, item and part identification numbers for each part ordered will ensure positive identification of parts. Before ordering parts however, refer to paragraph 8.7 spare parts.

NOTE

Replacement parts for all OEM engineering evaluation units (BRXXXX TMA099) must be obtained from MPI OEM Engineering.

Table 8-1. Top Mechanical Assembly Configurator

		ITEM NUMBERS						
MODELS	I	1111111111	1111111111	1111111111	1111111111	1111111111	1111111111	1111111111
	T T	0000000001	1111111112	2222222223	3333333334	4444444445	5555555556	6666666667
	A M	1234567890	1234567890	1234567890	1234567890	1234567890	1234567890	1234567890
BR803A	001	XX00000000	0000000000	0X000X0000	0X000X0000	XX0X0XX000	0000X00000	0000000000
BR803B	002	X0X0000000	0000000000	0X000X0000	0X0000X000	XX0X0XX000	0000X00000	0000000000
BR803C	003	X00X000000	0000000000	0X000X0000	0X0000X000	XX0X0XX000	0000X00000	0000000000
BR803D	004	X000X00000	0000000000	0X000X0000	0X0000X000	XX0X0XX000	0000X00000	0000000000
BR803E	005	X000000000	X000000000	0X000X0000	0X0000X000	XX0X0XX000	0000X00000	0000000000
BR803F	006	X00000X000	0000000000	0X000X0000	00X000X000	XX0X0XX000	0000X00000	0000000000
BR803G	007	X000000000	X000000000	0X000X0000	000X00X000	XX0X0XX000	0000X00000	0000000000
BR803H	008	X0X0000000	0000000000	0X000X0000	000X00X000	XX0X0XX000	0000X00000	0000000000
BR805A	009	XX00000000	0000000000	0X000X0000	0000X0X000	XX0X0XX000	0000X00000	0000000000
BR805B	010	X0X0000000	0000000000	0X000X0000	0000X0X000	XX0X0XX000	0000X00000	0000000000
BR805C	011	X00X000000	0000000000	0X000X0000	0000X0X000	XX0X0XX000	0000X00000	0000000000
BR805D	012	X00X000000	0000000000	0X000X0000	0000X0X000	XX0X0XX000	0000X00000	0000000000
BR803N	013	XX00000000	0000000000	0X000X0000	0000X0X000	XX0X0XX000	0000X00000	0000000000
BR803P	014	X0X0000000	0000000000	0X000X0000	0000X0X000	XX0X0XX000	0000X00000	0000000000
BR803R	015	X000X00000	0000000000	0X000X0000	0000X0X000	XX0X0XX000	0000X00000	0000000000
BR803S	016	X00X000000	0000000000	0X000X0000	0000X0X000	XX0X0XX000	0000X00000	0000000000
BR803J	017	X000000X00	0000X00000	0X000X0000	00X000X000	XX0X0XX0X0	0000X00000	0000000000
BR803K	018	X000000X00	0000X00000	0X000X0000	000X00X000	XX0X0XX0X0	0000X00000	0000000000
BR803L	019	X000000000	0000000000	0X000X000X	000000XX00	XX000XX0X0	0000X00000	0000000000
BR803M	020	X000000000	0000000000	0X000X00X0	000000XX00	XX000XX0X0	0000X00000	0000000000
BR8A3C	021	X000000X00	0000000000	0X000X0000	00X000X000	XX0X0XX0X0	0000X00000	0000000000
BR8A3D	022	X0000000X0	0000000000	0X000X0000	00X000X000	XX0X0XX0X0	0000X00000	0000000000
BR8A3E	023	X000000X00	0000000000	0X000X0000	000X00X000	XX0X0XX0X0	0000X00000	0000000000
BR8A3F	024	X0000000X0	0000000000	0X000X0000	000X00X000	XX0X0XX0X0	0000X00000	0000000000
BR8A2A	025	XX00000000	0000000000	0X000X0000	000000X000	XX0X0XX000	0000X00000	0000000000
BR803T	026	X0000X0000	0000000000	0X000X0000	0000X0X000	XX0X0XX000	0000X00000	0000000000
BR805E	027	X0000X0000	0000000000	0X000X0000	0000X0X000	XX0X0XX000	0000X00000	0000000000
BR8A3A	028	X000000000	X000000000	0X000X0000	0X0000X000	XX0X0XX000	0000X00000	0000000000
BR8A3B	029	0000000000	0000000000	0000000000	0000000000	0000000000	0000000000	0000000000
BR8A2B	030	X0X0000000	0000000000	0X000X0000	0X0000X000	XX0X0XX000	0000X00000	0000000000
BR8A2C	031	X00X000000	0000000000	0X000X0000	0X0000X000	XX0X0XX000	0000X00000	0000000000
BR8A2D	032	X0000X0000	0000000000	0X000X0000	0X0000X000	XX0X0XX000	0000X00000	0000000000
BR8A2E	033	X000X00000	0000000000	0X000X0000	0X0000X000	XX0X0XX000	0000X00000	0000000000
BR8A2F	034	X000000000	00X0000000	0X000X0000	0X0000X000	XX0X0XX000	0000X00000	0000000000
BR8A2G	035	XX00000000	0000000000	0X000X0000	0000000X00	XX0X0XX000	0000X00000	000000000X
BR8A2H	036	X000000000	0000000000	0X000X0000	0X00000X00	XX00XXX000	0000X00000	0000000000
BR8A2J	037	XX00000000	0000000000	0X000X0000	0X00000X00	XX0X0XX000	0000X00000	0000000000
BR8A2K	038	X000000000	00X0000000	0X000X0000	0X00000X00	XX0X0XX000	0000X00000	0000000000
BR8A2L	039	X00000X000	0000000000	0X000X0000	0X00000X00	XX0X0XX000	0000X00000	0000000000
BR8A2M	040	X000000X00	0000000000	0X000X0000	0X00000X00	XX0X0XX0X0	0000X00000	0X00000000
BR8A2N	041	X000X00000	0000000000	0X000X0000	0X00000X00	XX0X0XX000	0000X00000	0000000000
BR8A2P	042	00000000X0	0000X00000	0X000X0000	X00000000X	00XX0X00X0	0000X0000X	000X000X00
BR8A2R	043	0000000000	0000000000	0000000000	0000000000	0000000000	0000000000	0000000000
BR8A4A	044	0000000000	0000X00000	0X000XXX00	X00000X00X	00X00X00X0	0X00XXX000	000X0000X0
BR8A4B	045	0000000000	0000000000	0000000000	0000000000	0000000000	0000000000	0000000000
BR8A7A	046	00000000X0	0000X00000	0X000X0000	X00000000X	00XX0X00X0	0000X00000	000X0000X0
BR8A5A	047	X0000000X0	0000000000	0X000X0000	0000000X00	XX0X0XX0X0	0000X00000	XX00000000
BR8A5B	048	X000000X00	0000000000	0X000X0000	0000000X00	XX0X0XX0X0	0000X00000	XX00000000
BR8A2W	049	X00000X000	0000000000	0X000X0000	0X0000X000	XX0X0XX000	0000X00000	0000000000
BR8A2Y	050	X000000000	00X0000000	0X000X0000	0X00000X00	XX0X0XX000	0000X00000	0000000000
BR8A6B	051	X0X0000000	0000000000	0X000X0000	0X0000X000	XX0X0XX000	0000X00000	0000000000
BR803U	052	X000000000	X000000000	0X000X0000	0X0000X000	XX0X0XX000	0000X00000	0000000000
BR8A2S	053	X000000X00	0000000000	0X000X0000	0X00000X00	XX0X0XX0X0	0000X00000	0000000000
BR8A2T	054	X000000X00	0000000000	0X000X0000	0X00000X00	XX0X0XX0X0	0000X00000	0000000000
BR8A2U	055	X000000000	X000000000	0X000X0000	00X000X000	XX0X0XX000	0000X00000	0000000000
BR8A2V	056	X000000000	00X0000000	0X000X0000	0X00000X00	XX0X0XX000	0000X00000	0000000000
BR8A2Z	057	X0000000X0	0000000000	0X000X0000	0X00000X00	XX0X0XX0X0	0000X00000	0000000000
BR8A3G	058	XX00000000	0000000000	0X000X0000	0X00000X00	XX0X0XX000	0000X00000	0000000000
BR8A3H	059	X0X0000000	0000000000	0X000X0000	0X00000X00	XX0X0XX000	0000X00000	0000000000
	060	X000000000	00X0000000	0X000X0000	0X00000X00	XX0X0XX000	0000X00000	0000X00000
BR8A5C	061	X000000X00	0000000000	0X000X0000	0000000X00	XX0X0XX0X0	0000X00000	XX00000000
BR8A5D	062	X000000X00	0000000000	0X000X0000	0000000X00	XX0X0XX0X0	0000X00000	XX00000000
BR8A5E	063	XX00000000	0000000000	0X000X0000	0000000X00	XX0X0XX00X	0000X00000	0000000000
BR8A5J	064	XX00000000	0000000000	0X000X0000	0000000X00	XX0X0XX000	X000X00000	0000000000
BR8A5F	080	XX00000000	0000000000	0X000X0000	0X00000X00	XX0X0XX000	0000X00000	0000000000
BR8A5G	081	XX00000000	0000000000	0X000X0000	0X00000X00	XX0X0XX000	0000X00000	0000000000
BR8A5H	082	XX00000000	0000000000	0X000X0000	0000000X00	XX0X0XX000	X000X00000	0000000000
BRXXXX	099	OEM ENGINEERING UNIT						

ITEM NO	IDENT NO	DESCRIPTION	WHERE USED
101	83458201	CHASSIS ASM-COMMON PARTS	TMA
102	75291920	DRIVE MOTOR ASM 60 HZ	TMA
103	75291923	DRIVE MOTOR ASM 50 HZ	TMA
104	75291926	DRIVE MOTOR ASM 60 HZ	TMA
105	75291927	DRIVE MOTOR ASM 50 HZ	TMA
106	75291928	DRIVE MOTOR ASM 50 HZ	TMA
107	75291925	DRIVE MOTOR ASM 50 HZ	TMA
108	75881778	DRIVE MOTOR ASM 50 HZ	TMA
109	75881775	DRIVE MOTOR ASM 60 HZ	TMA
111	75291921	DRIVE MOTOR ASM 60 HZ	TMA
113	75291924	DRIVE MOTOR ASM 60 HZ	TMA
115	75891480	CHASSIS ASM-COMMON PARTS	TMA
122	94277416	STRAP, CABLE TIE	TMA
124	75291902	DRIVE MOTOR ASM 50 HZ	TMA
125	83427801	WRITE PROTECT ASM	TMA
126	92602001	CLAMP	TMA
127	77830690	DISKETTE DETECT ASM	TMA
128	75881779	DRIVE MOTOR ASM 60 HZ	TMA
129	75881780	DRIVE MOTOR ASM 50 HZ	TMA
130	75881781	DRIVE MOTOR ASM 60 HZ	TMA
131	83401806	FRONT PANEL ASM	TMA
132	83401801	FRONT PANEL ASM	TMA
133	83401802	FRONT PANEL ASM	TMA
134	83401803	FRONT PANEL ASM	TMA
135	83401804	FRONT PANEL ASM	TMA
136	83401805	FRONT PANEL ASM	TMA
137	75791510	ACTUATOR ASM	TMA
138	75791511	ACTUATOR ASM	TMA
140	77830685	UPPER HARNESS ASM	TMA
141	75747301	UPPER HARNESS ASM	TMA
142	83403502	LOWER HARNESS ASM	TMA
143	83403503	LOWER HARNESS ASM	TMA
144	83403700	CONNECTOR BRACKET	TMA

ITEM NO	IDENT NO	DESCRIPTION	WHERE USED
145	75272300	CONNECTOR BRACKET	TMA
146	77830538	CSA LABEL	TMA
147	77594901	TRACK SWITCH ASM	TMA
148	83460101	AMP CONN KIT	TMA
149	75746702	CAPACITOR BRACKET	TMA
150	75898080	FRONT PANEL BRACKET	TMA
151	83401809	FRONT PANEL ASM	TMA
152	77832691	MOUNTING KIT	TMA
155	93592240	SCREW-WASHER	TMA
156	77830641	AC CONN & RELAY ASM	TMA
157	77830995	COVER	TMA
158	17901508	SCREW	TMA
160	77834336	LABEL, FCO	TMA
161	77834543	FRONT PANEL ASSY	TMA
162	75746701	CAPACITOR BRACKET	TMA
164	77836055	LABEL	TMA
168	77594704	OPT TRACK SENSE ASSY	TMA
169	77594705	OPT TRACK SENSE ASSY	TMA
170	83401808	FRONT PANEL ASSY	TMA
336	93592160	SCREW, SELF TAP	TMA

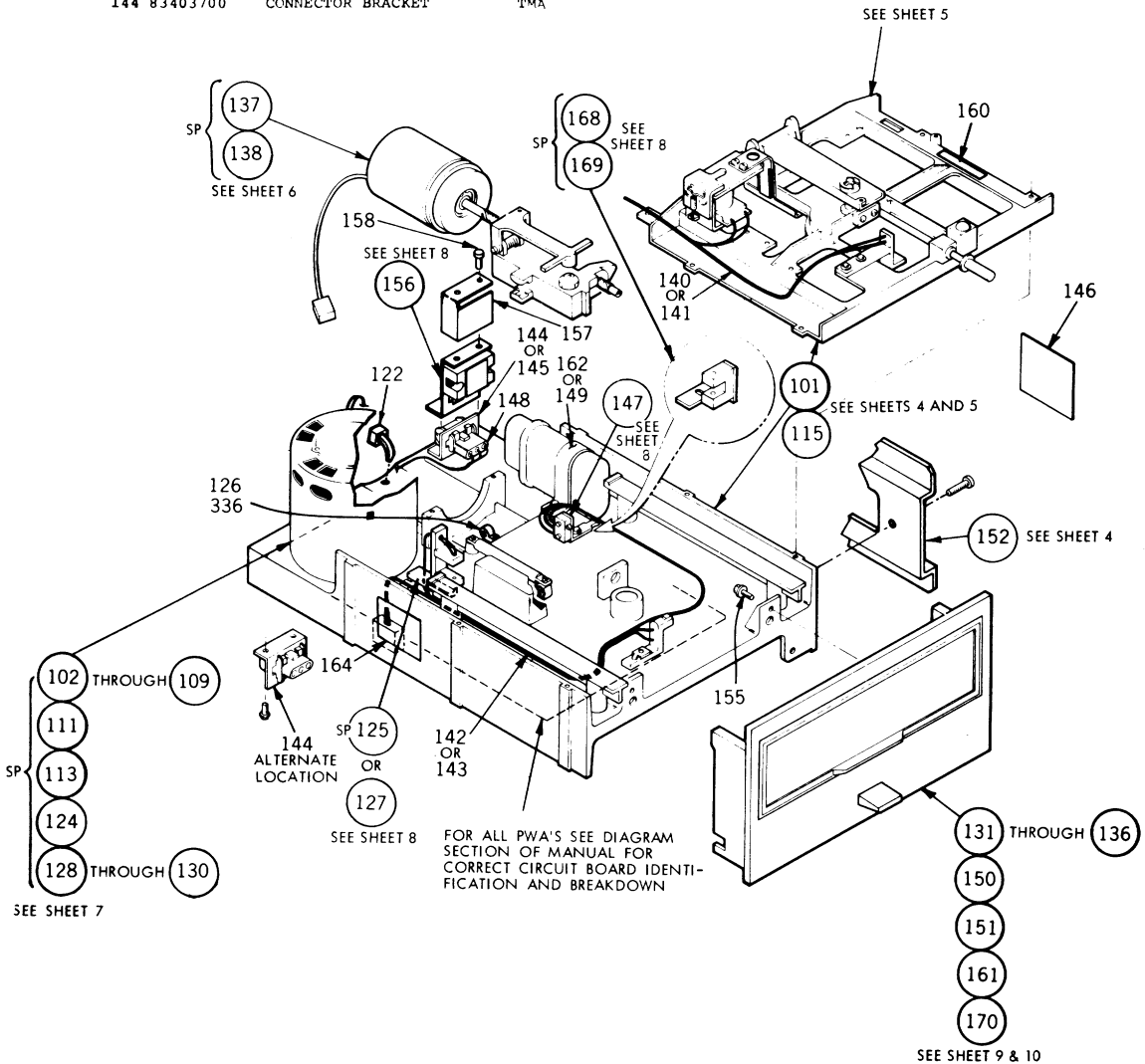

Figure 8-1. Top Mechanical Assembly

ITEM NO	IDENT NO	DESCRIPTION	WHERE USED
101	83458201	CHASSIS ASM-COMMON PARTS	TMA
115	75891480	CHASSIS ASM-COMMON PARTS	TMA
152	77832691	MOUNTING KIT	TMA
178	10125801	WASHERS SPR LOCK	101 115
180	75293203	BELT-PIAT	101 115
183	75774732	CLIP-PUSH IN	101 115
184	75774736	CLIP-PUSH IN	101 115
186	10125803	WASHERS SPR LOCK	101 115
187	10125605	WASHERS PLAIN	101 115
188	77832145	LABEL IDENT	101 115
190	94217702	NUT-SELF LOCK, STL 8	101 115
191	92073022	BEARING FLANGED	101 115
192	93529005	WASHER-SPRING WAVE	101 115
196	16402506	CLAMP CABLE	101 115
199	09000403	SCREW BIND HEAD	101 115
202	10126222	SCR HEX SELF TAP	101 115
205	93592086	CLAMP, CABLE-NYLON	101 115
208	92602003	SCR HEX SOC HD	101 115
209	10126214	PLATE-NUT	101 115
210	83427900	CARRIAGE STOP	101,115
218	75882450	SCREW	101,115
219	93592488	SCREW	152
255	10127131	LOCK WASHER	152
256	10125805	ADAPTER	152
301	77830975	SCREW, SELF TAP	101 115
336	93592160	STAR LOCK WASHER	101 115
339	10126401	ELECTRICAL SYMBOL	101 115
340	75731302	DECAL	152
342	77594800	BASE-MECHANISM, DIE	101
360	75886086	SPINDLF	101 115
361	83403601	SPACER BEARING	101 115
362	75747000	PULLEY-SPINDLF	101 115
363	75745200	BASE-MECHANISM, DIE	115
364	75886087	CLAMP, STEPPER MOTOR	101 115
365	83461800	GUIDE-CARRIAGE	101 115
366	75292400	SCREW	101 115
367	93592486	WASHER	101 115
388	10125603		

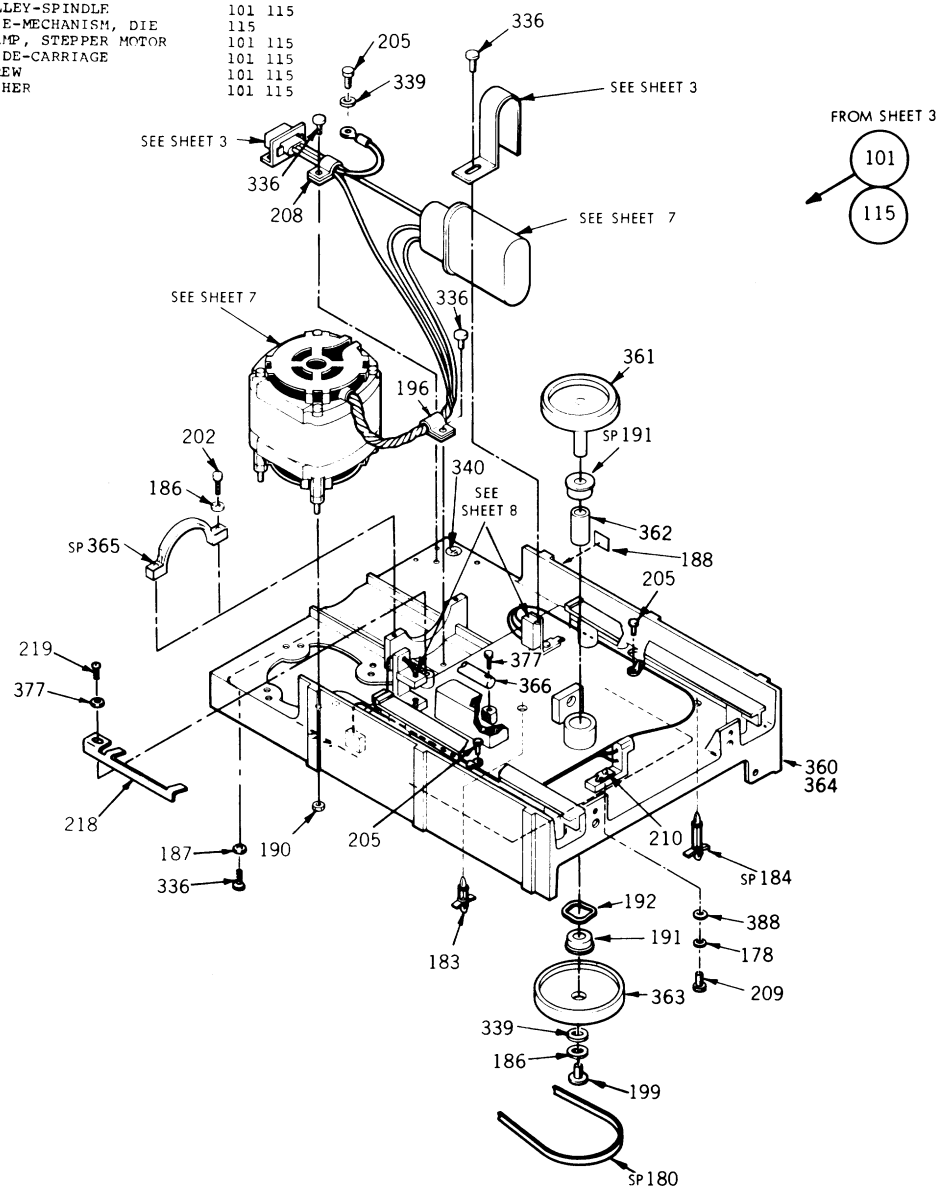
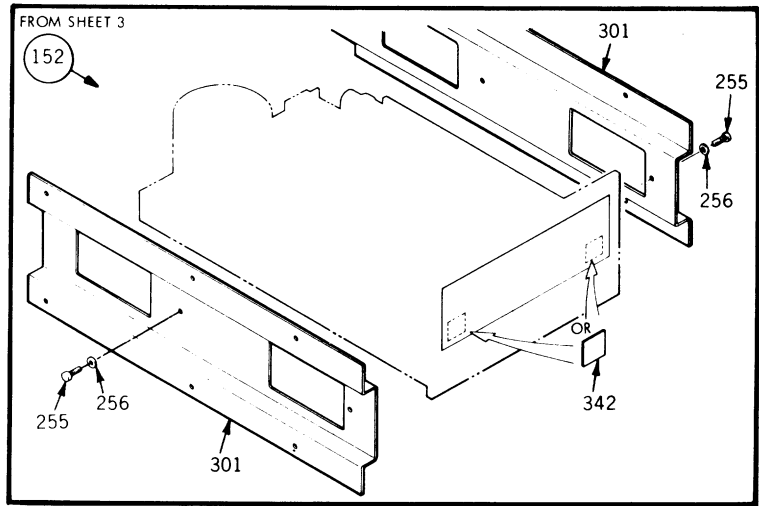
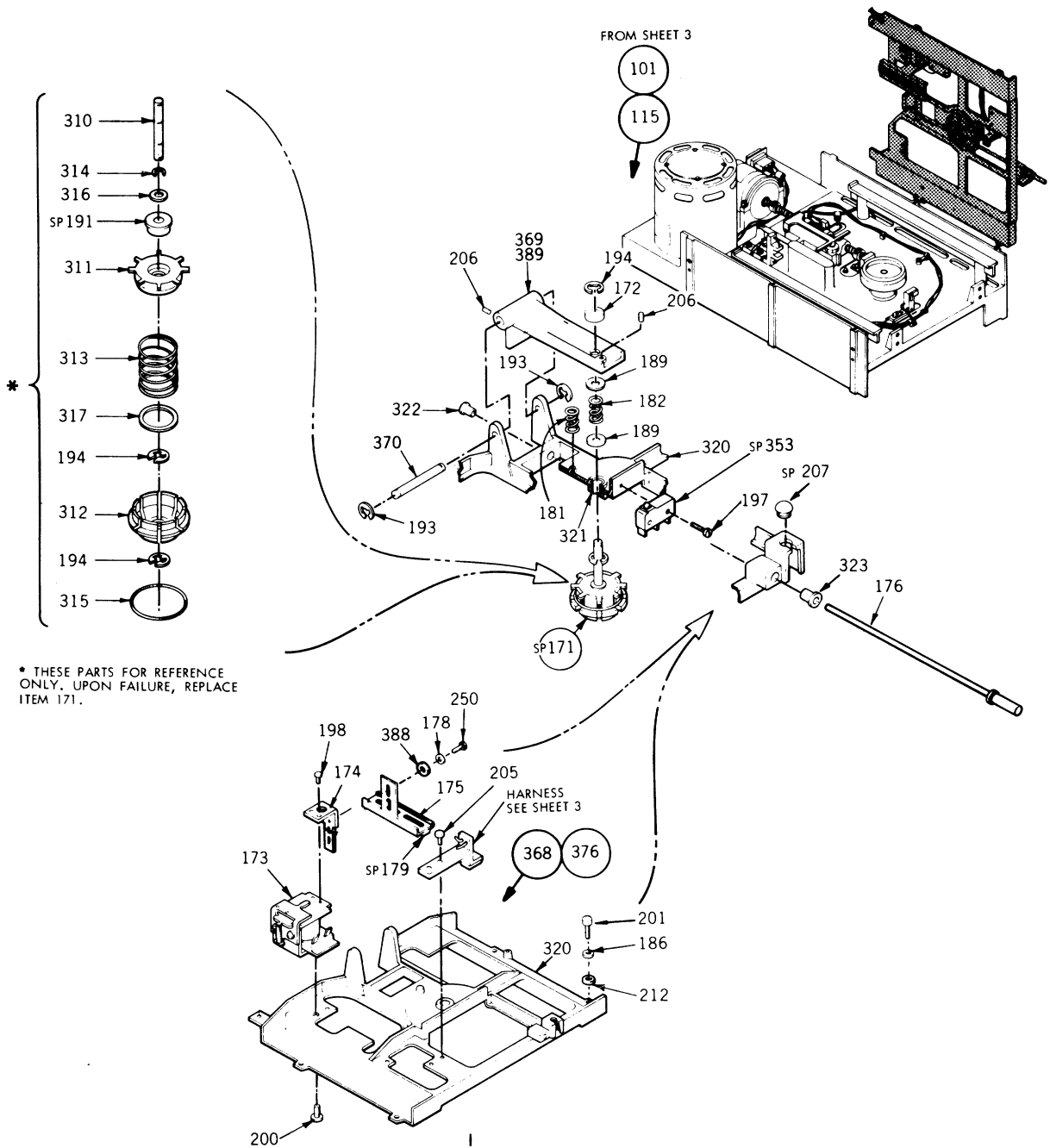

Figure 8-2. FDD Common Parts (Sheet 1 of 2)



ITEM NO	IDENT NO	DESCRIPTION	WHERE USED
101	83458201	CHASSIS ASM-COMMON PARTS	TWA
115	75891480	CHASSIS ASM-COMMON PARTS	TWA
171	83402101	CONE ASM	101 115
172	75273200	BUSHING	101 115
173	75747202	SOLENOID	101 115
174	77834331	EXTENSION ARMATURE	101 115
175	77834326	BAIL ARMATURE	101 115
176	75885163	PUSH ROD ASSY	101 115
178	10125801	WASHERS SPR LOCK	101 115
179	77830732	FOAM PAD	101 115
181	75292609	SPRING-COMPRESSION	101 115
182	75292617	SPRING-COMPRESSION	101 115
186	10125803	WASHERS SPR LOCK	101 115
189	77835200	WASHER, NYLON	101 115
191	92073022	BEARING FLANGED	171
193	92033037	RING RETAINING	101 115
194	92033038	RETAINING RING	101 171
194	92033038	RETAINING RING	115
197	09000005	SCREW BIND HEAD	101 115
198	09000202	SCREW BIND HEAD	101 115
200	09000504	SCREW BIND HEAD	101 115
201	10126219	SCR HEX SOC HD CAP	101 115
205	93592086	SCR HEX SELF TAP	101 115

WHERE USED

ITEM NO	IDENT NO	DESCRIPTION	WHERE USED
206	83413408	SCREW-SELF LOCKING	101 115
207	83411202	BUMPER DOOR	101 115
212	94279109	FLAT WASHER	101 115
250	93592482	SCR HEX HD	101 115
310	75790803	SHAFT	171
311	83426400	EXPANDER-CONE	171
312	77830481	CONE-DISK LOAD	171
313	83402200	SPRING CONE	171
314	92033029	RETAINING RING	171
315	83409701	SPRING-GARTER	171
316	94047069	WASHER	171
317	94047070	WASHER	171
320	75812011	SUPPORT DIE CAST MACHINED	368
321	75292807	BEARING-CYLINDRICAL	368
322	75813201	BUSHING, PUSH ROD MOLDED	368
323	75813202	BUSHING, PUSH ROD MOLDED	368
353	75724401	ACTUATOR SWITCH	101 115
368	75812021	SUPPORT-ASSEMBLED	101
369	83402803	ARM-DISK LOAD	101
370	75273000	PIN DISK LOAD ARM	101 115
376	75812022	SUPPORT-ASSEMBLED	115
388	10125603	WASHER	101 115
389	83402804	ARM-DISK LOAD	115

WHERE USED

Figure 8-2. FDD Common Parts (Sheet 2 of 2)

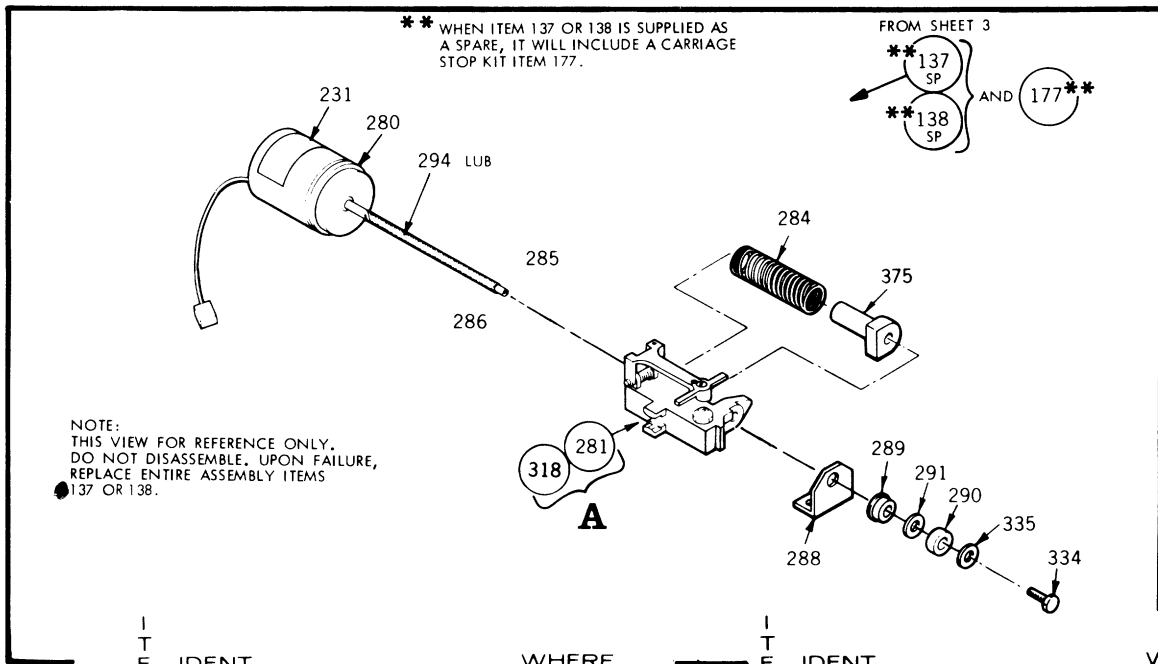

ITEM NO	DESCRIPTION	WHERE USED
137	ACTUATOR ASM	TMA
138	ACTUATOR ASM	TMA
177	CARRIAGE STOP KIT	137 138
231	CAUTION LABEL	137 138
257	HOLDER PAD	326
280	STEPPER MOTOR ASM	137 138
281	CARRIAGE ASM	137
284	SPRING-CARRIAGE	137 138
286	SCR-SOC HP CAP	281 318
288	RETAINER-BEARING	137 138
289	BEARING FLANGED	137 138
290	BRG BALL-EXT INNER R	137 138
291	WASHER-SPRING WAVE	137 138
294	LUBRICANT	137 138
306	PAD HEAD LOAD	326
318	CARRIAGE ASSY	138
325	ARM-HEAD LOAD	281 318
326	HOLDER-PAD ASSY	281 318
329	PIN CARRIAGE	281 318
330	SPRING TORSION	281 318
331	WASHER, SPECIAL	281 318
333	SCREW SLOTTED	281 318
334	SCREW HEX HD	137 138
335	WASHER	137 138

ITEM NO	DESCRIPTION	WHERE USED
346	CARRIAGE HEAD ASSY	281
358	CARRIAGE HEAD ASSY	318
373	CARRIAGE LABEL	324 358
375	NUT CARRIAGE	137 138

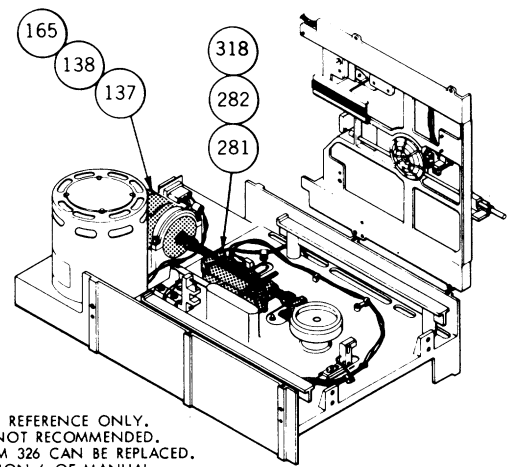
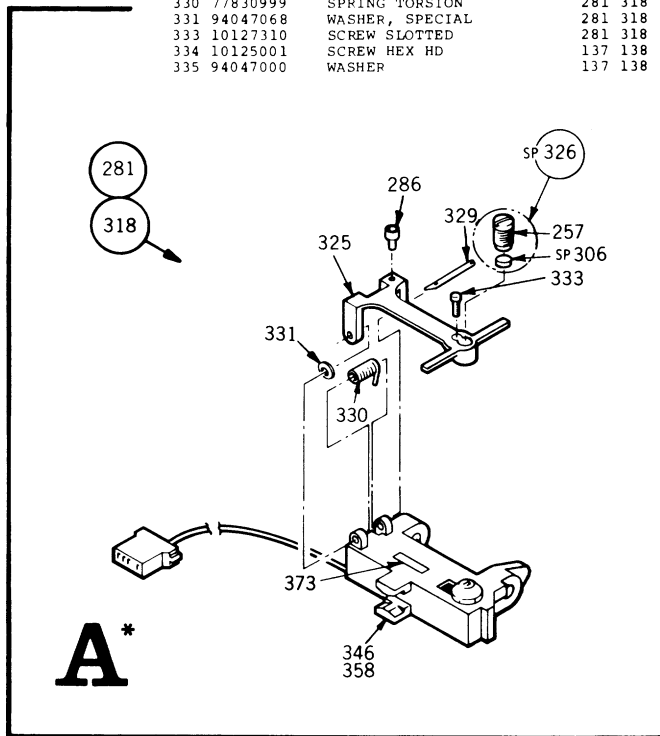
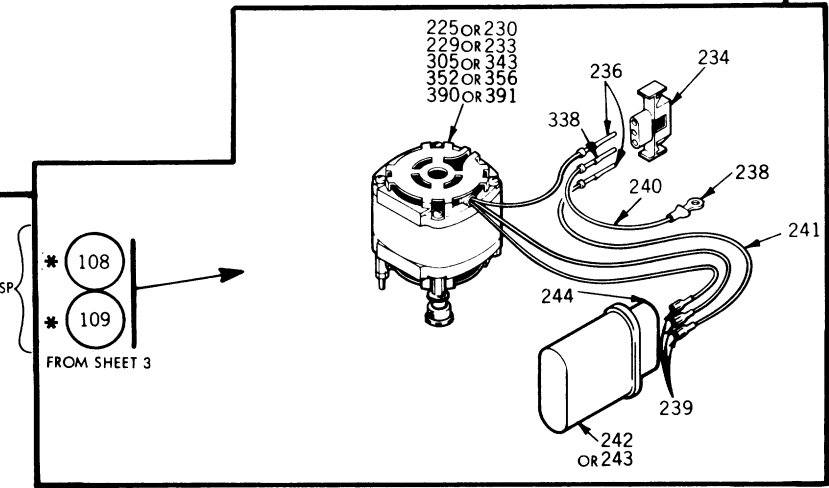
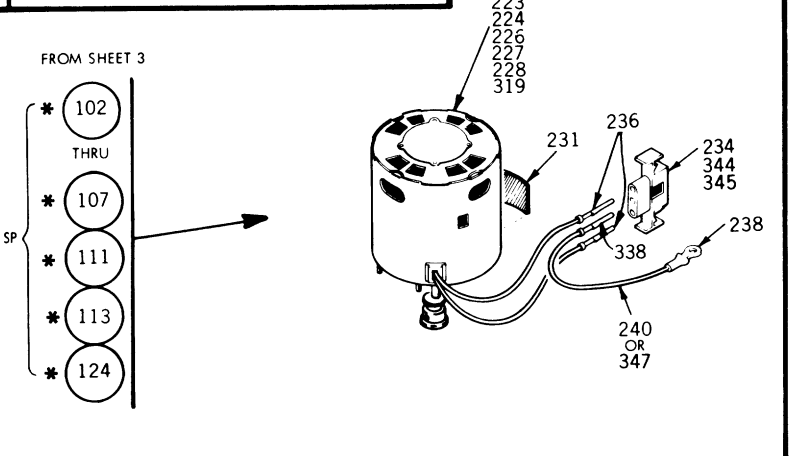
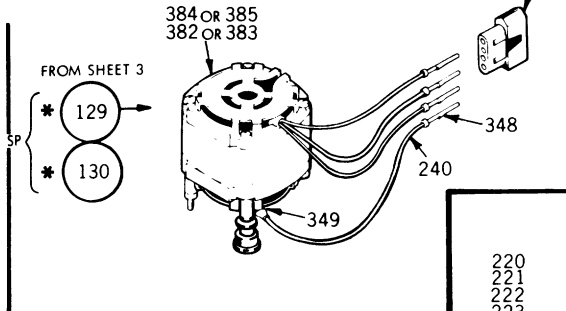
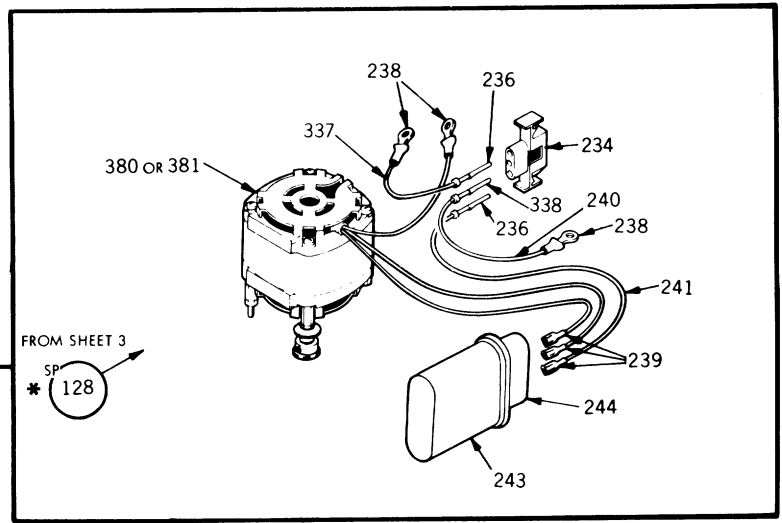

Figure 8-3. Actuator and Carriage Assemblies

ITEM NO	IDENT NO	DESCRIPTION	WHERE USED
102	75291920	DRIVE MOTOR ASM 60 HZ	TMA
103	75291923	DRIVE MOTOR ASM 50 HZ	TMA
104	75291926	DRIVE MOTOR ASM 60 HZ	TMA
105	75291927	DRIVE MOTOR ASM 50 HZ	TMA
106	75291928	DRIVE MOTOR ASM 50 HZ	TMA
107	75291925	DRIVE MOTOR ASM 50 HZ	TMA
108	75881778	DRIVE MOTOR ASM 50 HZ	TMA
109	75881775	DRIVE MOTOR ASM 60 HZ	TMA
111	75291921	DRIVE MOTOR ASM 60 HZ	TMA
113	75291924	DRIVE MOTOR ASM 60 HZ	TMA
124	75291902	DRIVE MOTOR ASM 50 HZ	TMA
128	75881779	DRIVE MOTOR ASM 60 HZ	TMA
129	75881780	DRIVE MOTOR ASM 50 HZ	TMA
130	77881781	DRIVE MOTOR ASM 60 HZ	TMA



ITEM NO	IDENT NO	DESCRIPTION	WHERE USED
220	77833503	MOTOR PULLEY ASSY	111
221	77833504	MOTOR PULLEY ASSY	103
222	77833519	MOTOR PULLEY ASSY	107
223	77833520	MOTOR PULLEY ASSY	105
224	77833507	MOTOR PULLEY ASSY	106
225	77833535	MOTOR PULLEY ASSY	109
226	77833502	MOTOR PULLEY ASSY	102
227	77833501	MOTOR PULLEY ASSY	124
228	77833506	MOTOR PULLEY ASSY	104
229	77833527	MOTOR PULLEY ASSY	108
230	77833525	MOTOR PULLEY ASSY	109
231	75790000	CAUTION LABEL	124 139
231	75790000	CAUTION LABEL	102-107
231	75790000	CAUTION LABEL	111 112
231	75790000	CAUTION LABEL	113
233	77833532	MOTOR PULLEY ASSY	108
234	83435402	CONNECTOR	102-110
234	83435402	CONNECTOR	113 114
234	83435402	CONNECTOR	111 112
234	83435402	CONNECTOR	128 139
236	83435501	CONTACT PIN	102-128
236	83435501	CONTACT PIN	139
238	51797233	TERMINAL	102-128
238	51797233	TERMINAL	114 139
239	62121108	TERMINAL	108-110
239	62121108	TERMINAL	114 128
239	62121108	TERMINAL	139
240	15003254	WIRE (YELLOW)	102-128
240	15003254	WIRE (YELLOW)	129 130
240	15003254	WIRE (YELLOW)	114 139
241	15003309	WIRE	106-110
241	15003309	WIRE	114 128
241	15003309	WIRE	139
242	75738478	CAPACITOR	110 114
242	75738478	CAPACITOR	139
243	75738421	CAPACITOR	109
243	75738421	CAPACITOR	114 128
243	75738421	CAPACITOR	108
244	75725000	CAPACITOR BOOT	108-110
244	75725000	CAPACITOR BOOT	114 128
244	75725000	CAPACITOR BOOT	139
305	77833526	MOTOR PULLEY ASSY	110
319	77833505	MOTOR PULLEY ASSY	113
337	93464000	WIRE BLACK	114 128
338	83435511	CONTACT PIN	102-128
338	83435511	CONTACT PIN	139
343	77833531	MOTOR PULLEY ASSY	110
344	75724543	CONNECTOR PANEL MTG	124
345	75724586	CONNECTOR PANEL MTG	124
347	93464555	WIPE 16 GRN	124
348	75724587	CONTACT PIN	129 130
349	51797214	LUG TERM RING CRIMP	129 130
350	75724569	CONNECTOR PANEL MTG	129 130
351	75724585	CONNECTOR PANEL MTG	129 130
352	77833542	MOTOR PULLEY ASSY	139
356	77833545	MOTOR PULLEY ASSY	139
380	77833526	MOTOR PULLEY ASSY	128
381	77833531	MOTOR PULLEY ASSY	128
382	77833525	MOTOR PULLEY ASSY	129
383	77833535	MOTOR PULLEY ASSY	129
384	77833527	MOTOR PULLEY ASSY	130
385	77833532	MOTOR PULLEY ASSY	130
390	77833529	MOTOR PULLEY ASSY	114
391	77833534	MOTOR PULLEY ASSY	114

* RECOMMENDED FIELD REPLACEMENT LEVEL. ALL OTHER PARTS SHOULD BE CONSIDERED REFERENCE DATA ONLY.

Figure 8-4. Drive Motor Assembly

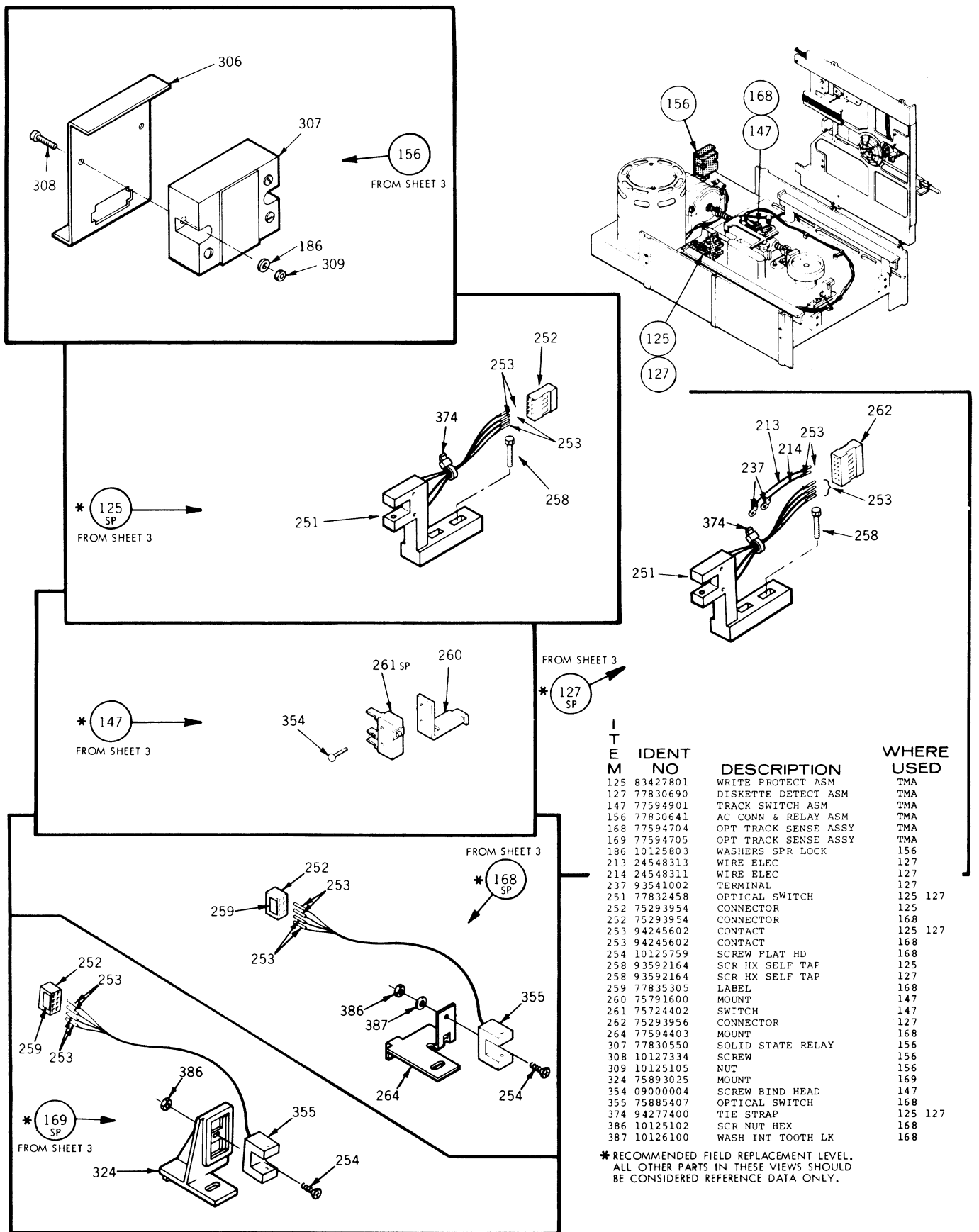

ITEM NO	DESCRIPTION	WHERE USED
125	83427801 WRITE PROTECT ASM	TMA
127	77830690 DISKETTE DETECT ASM	TMA
147	77594901 TRACK SWITCH ASM	TMA
156	77830641 AC CONN & RELAY ASM	TMA
168	77594704 OPT TRACK SENSE ASSY	TMA
169	77594705 OPT TRACK SENSE ASSY	TMA
186	10125803 WASHERS SPR LOCK	156
213	24548313 WIRE ELEC	127
214	24548311 WIRE ELEC	127
237	93541002 TERMINAL	127
251	77832458 OPTICAL SWITCH	125 127
252	75293954 CONNECTOR	125
252	75293954 CONNECTOR	168
253	94245602 CONTACT	125 127
253	94245602 CONTACT	168
254	10125759 SCR FLAT HD	168
258	93592164 SCR HX SELF TAP	125
258	93592164 SCR HX SELF TAP	127
259	77835305 LABEL	168
260	75791600 MOUNT	147
261	75724402 SWITCH	147
262	75293956 CONNECTOR	127
264	77594403 MOUNT	168
307	77830550 SOLID STATE RELAY	156
308	10127334 SCREW	156
309	10125105 NUT	156
324	75893025 MOUNT	169
354	09000004 SCREW BIND HEAD	147
355	75885407 OPTICAL SWITCH	168
374	94277400 TIE STRAP	125 127
386	10125102 SCR NUT HEX	168
387	10126100 WASH INT TOOTH LK	168

* RECOMMENDED FIELD REPLACEMENT LEVEL. ALL OTHER PARTS IN THESE VIEWS SHOULD BE CONSIDERED REFERENCE DATA ONLY.

Figure 8-5. Miscellaneous Sub-Assemblies

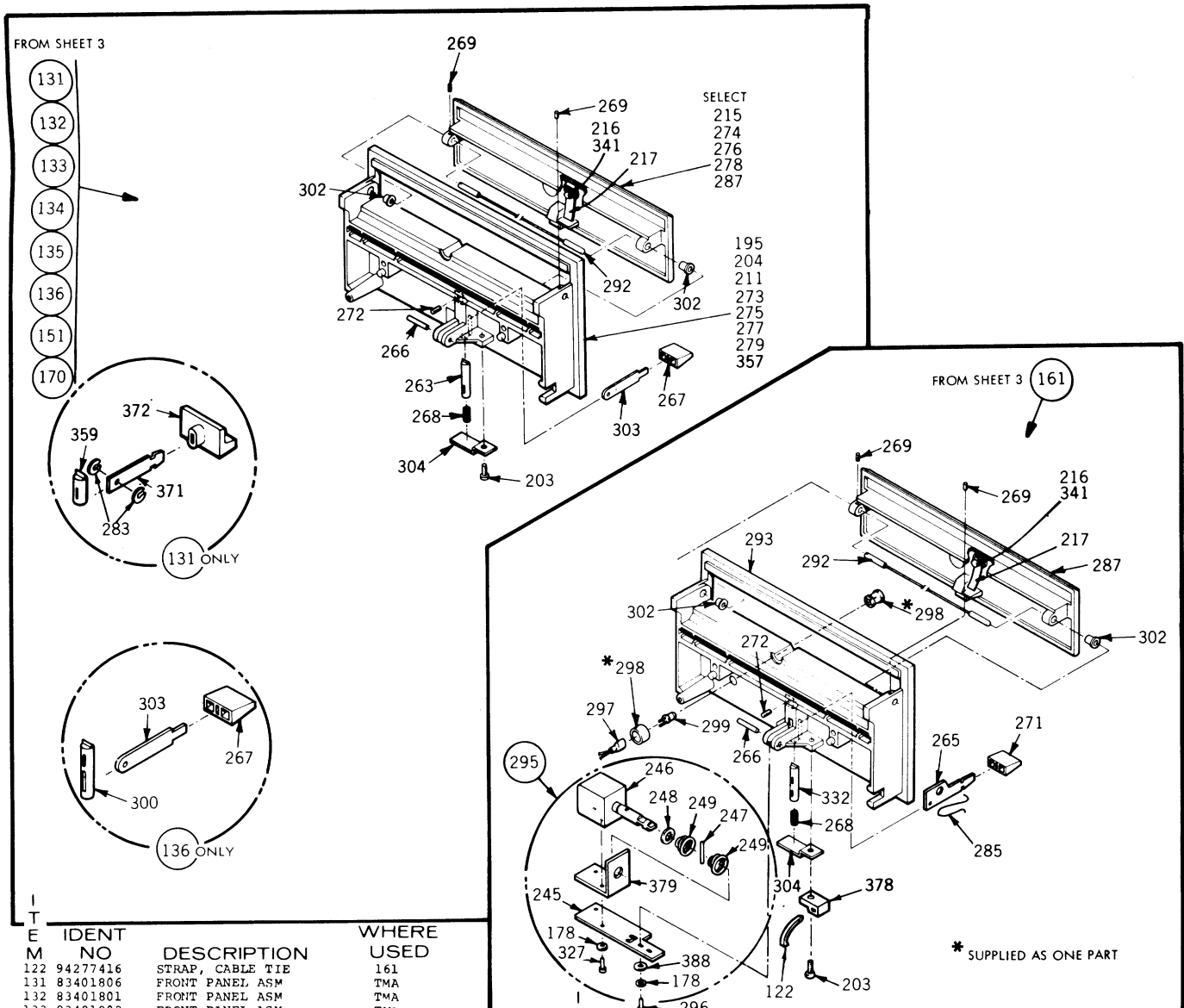

IDENT

M	NO	DESCRIPTION	WHERE USED
122	94277416	STRAP, CABLE TIE	161
131	83401806	FRONT PANEL ASM	TMA
132	83401801	FRONT PANEL ASM	TMA
133	83401802	FRONT PANEL ASM	TMA
134	83401803	FRONT PANEL ASM	TMA
135	83401804	FRONT PANEL ASM	TMA
136	83401805	FRONT PANEL ASM	TMA
151	83401809	FRONT PANEL ASM	TMA
161	77834543	FRONT PANEL ASSY	TMA
170	83401808	FRONT PANEL ASSY	TMA
195	83426624	PANEL FRONT FIN BLK	132
203	93592162	SCR HX WASHER SLF TA	131-136
203	93592162	SCR HX WASHER SLF TA	161 170
204	75898043	PANEL, FRONT, FIN BLK	151
211	83426626	PANEL FRONT FIN BLU	170
215	75812126	DOOR FINISHED BLU	170
216	93592080	SCR HEX WSR HD	131-136
216	93592080	SCR HEX WSR HD	161 170
217	75884657	LEAF SPRING	131-136
217	75884657	LEAF SPRING	161 170
245	77835131	SOLENOID BRKT	295
246	77834212	SOLENOID	295
247	93530103	PIN ROLL	295
248	75806507	WASHER	295
249	77834323	SPRING	295
263	83402301	LATCH-DOOR INJEC MOL	132-135
263	83402301	LATCH-DOOR INJEC MOL	170
265	77834318	LEVER-DOOR	161
266	92096099	PIN-GROOVED	131-136
266	92096099	PIN-GROOVED	161 170
267	75292700	KNOB-LEVER	132-136
267	75292700	KNOB-LEVER	170
268	83401200	SPRING-LATCH	131-136
268	83401200	SPRING-LATCH	161 170
269	83413406	SCR SET SOC HD 6-32	131-136
269	83413406	SCR SET SOC HD 6-32	161 170
271	75292701	KNOB-LEVER	161
272	83413404	SCREW-SELF LOCKING	131-136
272	83413404	SCREW-SELF LOCKING	161 170
273	83426621	PANEL FRONT, BLACK HW	133
274	75812121	DOOR, FINISHED, PA-BLK	133

IDENT

M	NO	DESCRIPTION	WHERE USED
275	83426622	PANEL FRONT, WHITE HW	134
276	75812122	DOOR, FINISHED, PA-WHT	134
277	83426623	PANEL FRONT, FIN BLUE	135
278	75812123	DOOR, FINISHED, PA-BLU	135
279	83461110	FRONT PANEL FINISHED	136
283	75881371	SHIM	131
285	75896352	DOOR LEVER SPRING	161
287	75812124	DOOR FINISHED BLACK	132 136
287	75812124	DOOR FINISHED BLACK	131 161
292	83403202	BAR TORSION DOOR	131-136
292	83403202	BAR TORSION DOOR	161 170
293	83461111	FRONT PANEL	161
295	77835133	DOOR LK ASSY	161
296	91976207	SCREW	161
297	77833702	HARNESS DR LK	161
298	75810703	RETAINING RING	161
299	75810701	DIODE LIGHT	161
300	83461200	LATCH DOOR	136
302	83401500	BUSHING-DOOR INJECT	131-136
302	83401500	BUSHING-DOOR INJECT	161 170
303	75746000	LEVER-DOOR	132-136
303	75746000	LEVER-DOOR	170
304	75746800	BRACKET LATCH	131-136
304	75746800	BRACKET LATCH	161 170
327	10127321	SCR PAN HD	295
332	75889161	LATCH DOOR	161
341	10126400	WASH EXT TOOTH LK	161 170
341	10126400	WASH EXT TOOTH LK	131-136
357	77832410	PANEL FRONT BLK-BURR	131
359	77830977	LATCH DOOR	131
371	75881370	LEVER DOOR	131
372	77832119	BUTTON LATCH	131
378	95862300	ANCHOR CABLE TIE	161
379	77835132	SPACER BKT	295

Figure 8-6. Front Panel Assembly (Sheet 1 of 2)

FROM SHEET 3

150

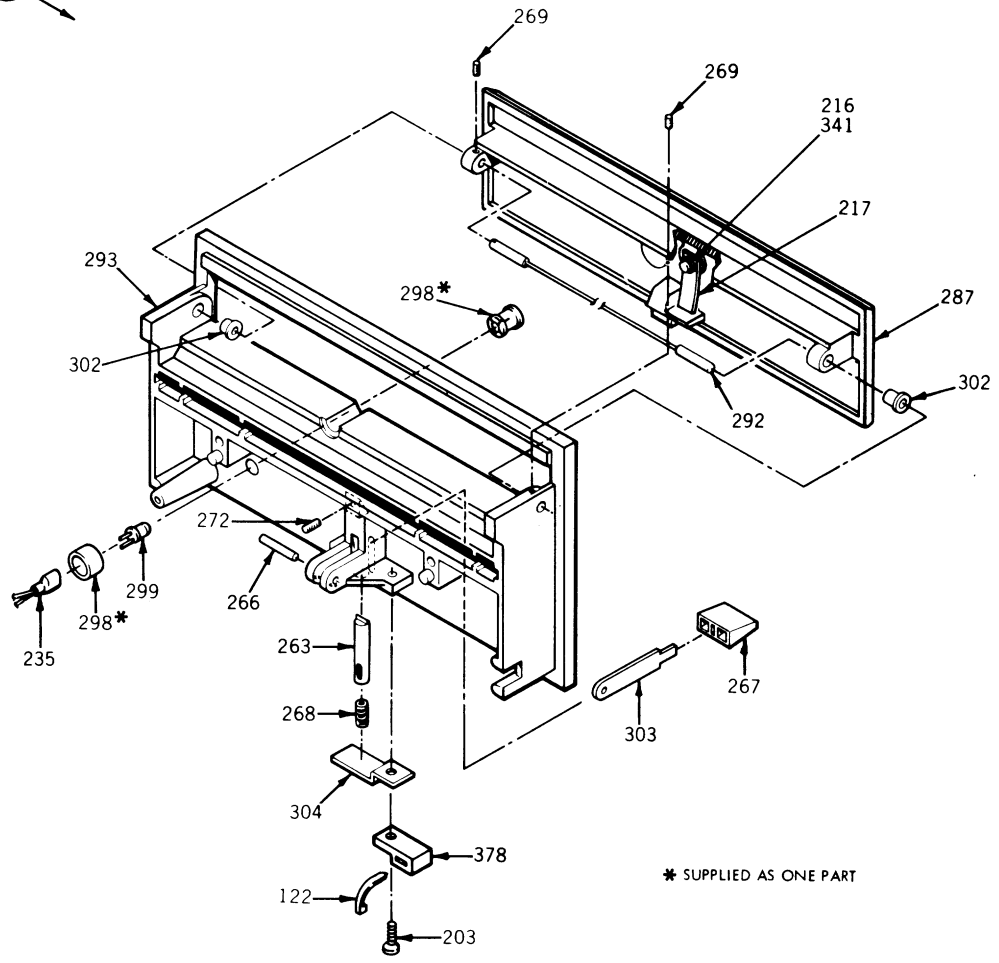

* SUPPLIED AS ONE PART

ITEM NO	IDENT NO	DESCRIPTION	WHERE USED
122	94277416	STRAP, CABLF TIE	150
150	75898080	FRONT PANEL ASM	TWA
203	93592162	SCR HX WASHR SLF TA	150
216	93592080	SCR HEX WSR HD	150
217	75884657	LEAF SPRING	150
235	75898086	HARNES	150
263	83402301	LATCH-DOOR INJEC MOL	150
266	92096099	PIN-GROOVED	150
267	75292700	KNOB-LEVER	150
268	83401200	SPRING-LATCH	150
269	83413406	SCR SET SOC HD 6-32	150
272	83413404	SCREW-SELF LOCKING	150
287	75812124	DOOR FINISHED BLACK	150
292	83403202	BAR TORSION DOOR	150
293	83461111	FRONT PANEL	150
298	75810703	RETAINING RING	150
299	75810701	DIODE LIGHT	150
302	83401500	BUSHING-DOOR INJFCT	150
303	75746000	LEVER-DOOR	150
304	75746800	BRACKET LATCH	150
341	10126400	WASH EXT TOOTH LK	150
378	95862300	ANCHOR CABLF TIE	150

Figure 8-6. Front Panel Assembly (Sheet 2 of 2)

8.6 PARTS LIST INSTRUCTIONS

8.6.1 ILLUSTRATION PARTS LISTS

The parts list for each illustration is an extract from the Top-Down Assembly/Component Parts list and contains only those parts depicted. Refer to paragraph 8.6.2 for explanation of parts list.

8.6.2 TOP-DOWN ASSEMBLY/COMPONENT PARTS LIST

- a. Starts at TMA level and lists all parts in Item Number sequence.
- b. Correlates Item numbers with part Identification numbers and the Description of each.
- c. Identifies where each part is used (where used column) within the device by listing the item number(s) of the next higher assembly.

NOTE

Where used data for Figure 8-1 is labeled TMA. Refer to Table 8-1 for correct application of parts (refer to paragraph 8.4).

- d. Defines the location of each part by listing the sheet number(s) where depicted.

NOTE

The same part may be used in any number of assemblies or sheet locations.

8.6.3 CROSS REFERENCE INDEX

- a. Lists all parts in numeric sequence (by Identification Number).
- b. In conjunction with the referenced sheet number (third column) and illustrations defines the physical location of each item identified.

8.6.4 SHEET NUMBER REFERENCING

Sheet number references of Parts Lists and Illustrations refers to sheet locations in this section. Example: Sheet reference 3 represents sheet 8-3, sheet 4 represents sheet 8-4, etc.

8.7 SPARE PARTS (SP)

This Illustrated Parts Breakdown is complete to the extent that all parts and assemblies are depicted and identified. Replacement part availability depends on the materials and provisioning operation of the supplier.

To assist the service representative in selecting replacement parts with minimum requisitioning lead times, engineering recommended spare parts which reflect the intended service level of the device are identified with the letters SP adjacent to the item number on the face of each illustration. Replaceable non-spared items will require longer requisitioning lead times.

Top-Down Assembly/Component Parts List

I T E M	IDENT NO	DESCRIPTION	WHERE USED		I T E M	IDENT NO	DESCRIPTION	WHERE USED	
			TMA	SH				TMA	SH
101	83458201	CHASSIS ASM-COMMON PARTS	TMA	S3	179	77830732	FOAM PAD	101 115	S5
101	83458201	CHASSIS ASM-COMMON PARTS	TMA	S4	180	75293203	BELT-FLAT	101 115	S4
101	83458201	CHASSIS ASM-COMMON PARTS	TMA	S5	181	75292609	SPRING-COMPRESSION	101 115	S5
102	75291920	DRIVE MOTOR ASM 60 HZ	TMA	S3	182	75292617	SPRING-COMPRESSION	101 115	S5
102	75291920	DRIVE MOTOR ASM 60 HZ	TMA	S7	183	75774732	CLIP-PUSH IN	101 115	S4
103	75291923	DRIVE MOTOR ASM 50 HZ	TMA	S3	184	75774736	CLIP-PUSH IN	101 115	S4
103	75291923	DRIVE MOTOR ASM 50 HZ	TMA	S7	186	10125803	WASHERS SPR LOCK	101 115	S4
104	75291926	DRIVE MOTOR ASM 60 HZ	TMA	S3	186	10125803	WASHERS SPR LOCK	101 115	S5
104	75291926	DRIVE MOTOR ASM 60 HZ	TMA	S7	186	10125803	WASHERS SPR LOCK	156	S8
105	75291927	DRIVE MOTOR ASM 50 HZ	TMA	S3	187	10125605	WASHERS PLAIN	101 115	S4
105	75291927	DRIVE MOTOR ASM 50 HZ	TMA	S7	188	77832145	LABEL IDENT	101 115	S4
106	75291928	DRIVE MOTOR ASM 50 HZ	TMA	S3	189	77835200	WASHER, NYLON	101 115	S5
106	75291928	DRIVE MOTOR ASM 50 HZ	TMA	S7	190	94217702	NUT-SELF LOCK, STL 8	101 115	S4
107	75291925	DRIVE MOTOR ASM 50 HZ	TMA	S3	191	92073022	BEARING FLANGED	101 115	S4
107	75291925	DRIVE MOTOR ASM 50 HZ	TMA	S7	191	92073022	BEARING FLANGED	171	S5
108	75881778	DRIVE MOTOR ASM 50 HZ	TMA	S3	192	93529005	WASHER-SPRING WAVE	101 115	S4
108	75881778	DRIVE MOTOR ASM 50 HZ	TMA	S7	193	92033037	RING RETAINING	101 115	S5
109	75881775	DRIVE MOTOR ASM 60 HZ	TMA	S3	194	92033038	RETAINING RING	101 171	S5
109	75881775	DRIVE MOTOR ASM 60 HZ	TMA	S7	194	92033038	RETAINING RING	115	S5
111	75291921	DRIVE MOTOR ASM 60 HZ	TMA	S3	195	83426624	PANEL FRONT FIN BLK	132	S9
111	75291921	DRIVE MOTOR ASM 60 HZ	TMA	S7	196	16402506	CLAMP CABLE	101 115	S4
113	75291924	DRIVE MOTOR ASM 60 HZ	TMA	S3	197	09000005	SCREW BIND HEAD	101 115	S5
113	75291924	DRIVE MOTOR ASM 60 HZ	TMA	S7	198	09000202	SCREW BIND HEAD	101 115	S5
115	75891480	CHASSIS ASM-COMMON PARTS	TMA	S3	199	09000403	SCREW BIND HEAD	101 115	S4
115	75891480	CHASSIS ASM-COMMON PARTS	TMA	S4	200	09000504	SCREW BIND HEAD	101 115	S5
115	75891480	CHASSIS ASM-COMMON PARTS	TMA	S5	201	10126219	SCR HEX SOC HD CAP	101 115	S5
122	94277416	STRAP, CABLE TIE	TMA	S3	202	10126222	SCREW HEX SOC HD	101 115	S4
122	94277416	STRAP, CABLE TIE	161	S9	203	93592162	SCR HX WASHER SLF TA	131-136	S9
122	94277416	STRAP, CABLE TIE	150	S10	203	93592162	SCR HX WASHER SLF TA	161 170	S9
124	75291902	DRIVE MOTOR ASM 50 HZ	TMA	S3	203	93592162	SCR HX WASHER SLF TA	150	S10
124	75291902	DRIVE MOTOR ASM 50 HZ	TMA	S7	204	75898043	PANEL, FRONT, FIN BLK	151	S9
125	83427801	WRITE PROTECT ASM	TMA	S3	205	93592086	SCR HEX SELF TAP	101 115	S4
125	83427801	WRITE PROTECT ASM	TMA	S8	205	93592086	SCR HEX SELF TAP	101 115	S5
126	92602001	CLAMP	TMA	S3	206	83413408	SCREW-SELF LOCKING	101 115	S5
127	77830690	DISKETTE DETECT ASM	TMA	S3	207	83411202	BUMPER DOOR	101 115	S5
127	77830690	DISKETTE DETECT ASM	TMA	S8	208	92602003	CLAMP, CABLE-NYLON	101 115	S4
128	75881779	DRIVE MOTOR ASM 60 HZ	TMA	S3	209	10126214	SCR HEX SOC HD CAP	101 115	S4
128	75881779	DRIVE MOTOR ASM 60 HZ	TMA	S7	210	83427900	PLATE-NUT	101 115	S4
129	75881780	DRIVE MOTOR ASM 50 HZ	TMA	S3	211	83426626	PANEL FRONT FIN BLU	170	S9
129	75881780	DRIVE MOTOR ASM 50 HZ	TMA	S7	212	94279109	FLAT WASHER	101 115	S5
130	75881781	DRIVE MOTOR ASM 60 HZ	TMA	S3	213	24548313	WIRE ELEC	127	S8
130	77881781	DRIVE MOTOR ASM 60 HZ	TMA	S7	214	24548311	WIRE ELEC	127	S8
131	83401806	FRONT PANEL ASM	TMA	S3	215	75812126	DOOR FINISHED BLU	170	S9
131	83401806	FRONT PANEL ASM	TMA	S9	216	93592080	SCR HEX WSR HD	131-136	S9
132	83401801	FRONT PANEL ASM	TMA	S3	216	93592080	SCR HEX WSR HD	161 170	S9
132	83401801	FRONT PANEL ASM	TMA	S9	216	93592080	SCR HEX WSR HD	150	S10
133	83401802	FRONT PANEL ASM	TMA	S3	217	75884657	LEAF SPRING	131-136	S9
133	83401802	FRONT PANEL ASM	TMA	S9	217	75884657	LEAF SPRING	161 170	S9
134	83401803	FRONT PANEL ASM	TMA	S3	217	75884657	LEAF SPRING	150	S10
134	83401803	FRONT PANEL ASM	TMA	S9	218	75882450	CARRIAGE STOP	101,115	S4
135	83401804	FRONT PANEL ASM	TMA	S3	219	93592488	SCREW	101,115	S4
135	83401804	FRONT PANEL ASM	TMA	S9	220	77833503	MOTOR PULLEY ASSY	111	S7
136	83401805	FRONT PANEL ASM	TMA	S3	221	77833504	MOTOR PULLEY ASSY	103	S7
136	83401805	FRONT PANEL ASM	TMA	S9	222	77833519	MOTOR PULLEY ASSY	107	S7
137	75791510	ACTUATOR ASM	TMA	S3	223	77833520	MOTOR PULLEY ASSY	105	S7
137	75791510	ACTUATOR ASM	TMA	S6	224	77833507	MOTOR PULLEY ASSY	106	S7
138	75791511	ACTUATOR ASM	TMA	S3	225	77833535	MOTOR PULLEY ASSY	109	S7
138	75791511	ACTUATOR ASM	TMA	S6	226	77833502	MOTOR PULLEY ASSY	102	S7
140	77830685	UPPER HARNESS ASM	TMA	S3	227	77833501	MOTOR PULLEY ASSY	124	S7
141	75747301	UPPER HARNESS ASM	TMA	S3	228	77833506	MOTOR PULLEY ASSY	104	S7
142	83403502	LOWER HARNESS ASM	TMA	S3	229	77833527	MOTOR PULLEY ASSY	108	S7
143	83403503	LOWER HARNESS ASM	TMA	S3	230	77833525	MOTOR PULLEY ASSY	109	S7
144	83403700	CONNECTOR BRACKET	TMA	S3	231	75790000	CAUTION LABEL	137 138	S6
145	75272300	CONNECTOR BRACKET	TMA	S3	231	75790000	CAUTION LABEL	124 139	S7
146	77830538	CSA LABEL	TMA	S3	231	75790000	CAUTION LABEL	102-107	S7
147	77594901	TRACK SWITCH ASM	TMA	S3	231	75790000	CAUTION LABEL	111 112	S7
147	77594901	TRACK SWITCH ASM	TMA	S8	231	75790000	CAUTION LABEL	113	S7
148	83460101	AMP CONN KIT	TMA	S3	233	77833532	MOTOR PULLEY ASSY	108	S7
149	75746702	CAPACITOR BRACKET	TMA	S3	234	83435402	CONNECTOR	102-110	S7
150	75898080	FRONT PANEL ASM	TMA	S3	234	83435402	CONNECTOR	113 114	S7
150	75898080	FRONT PANEL ASM	TMA	S10	234	83435402	CONNECTOR	111 112	S7
151	83401809	FRONT PANEL ASM	TMA	S3	234	83435402	CONNECTOR	128 139	S7
151	83401809	FRONT PANEL ASM	TMA	S9	235	75898086	HARNESS	150	S10
152	77832691	MOUNTING KIT	TMA	S3	236	83435501	CONTACT PIN	102-128	S7
152	77832691	MOUNTING KIT	TMA	S4	236	83435501	CONTACT PIN	139	S7
155	93592240	SCREW-WASHER	TMA	S3	237	93541002	TERMINAL	127	S8
156	77830641	AC CONN & RELAY ASM	TMA	S3	238	51797233	TERMINAL	102-128	S7
156	77830641	AC CONN & RELAY ASM	TMA	S8	238	51797233	TERMINAL	114 139	S7
157	77830995	COVER	TMA	S3	239	62121108	TERMINAL	108-110	S7
158	17901508	SCREW	TMA	S3	239	62121108	TERMINAL	114 128	S7
160	77834336	LABEL, FCO	TMA	S3	239	62121108	TERMINAL	139	S7
161	77834543	FRONT PANEL ASSY	TMA	S3	240	15003254	WIRE (YELLOW)	102-128	S7
161	77834543	FRONT PANEL ASSY	TMA	S9	240	15003254	WIRE (YELLOW)	129 130	S7
162	75746701	CAPACITOR BRACKET	TMA	S3	240	15003254	WIRE (YELLOW)	114 139	S7
164	77836055	LABEL	TMA	S3	241	15003309	WIRE	106-110	S7
168	77594704	OPT TRACK SENSE ASSY	TMA	S3	241	15003309	WIRE	114 128	S7
168	77594704	OPT TRACK SENSE ASSY	TMA	S8	241	15003309	WIRE	139	S7
169	77594705	OPT TRACK SENSE ASSY	TMA	S3	242	75738478	CAPACITOR	110 114	S7
169	77594705	OPT TRACK SENSE ASSY	TMA	S8	242	75738478	CAPACITOR	139	S7
170	83401808	FRONT PANEL ASSY	TMA	S3	243	75738421	CAPACITOR	109	S7
170	83401808	FRONT PANEL ASSY	TMA	S9	243	75738421	CAPACITOR	114 128	S7
171	83402101	CONE ASM	101 115	S5	243	75738421	CAPACITOR	108	S7
172	75273200	BUSHING	101 115	S5	244	75772500	CAPACITOR BOOT	108-110	S7
173	75747202	SOLENOID	101 115	S5	244	75772500	CAPACITOR BOOT	114 128	S7
174	77834331	EXTENSION ARMATURE	101 115	S5	244	75772500	CAPACITOR BOOT	139	S7
175	77834326	BAIL ARMATURE	101 115	S5	245	77835131	SOLENOID BRKT	295	S9
176	75885163	PUSH ROD ASSY	101 115	S5	246	77834212	SOLENOID	295	S9
177	75882711	CARRIAGE STOP KIT	137 138	S6	247	93530103	PIN ROLL	295	S9
178	10125801	WASHERS SPR LOCK	101 115	S4	248	75806507	WASHER	295	S9
178	10125801	WASHERS SPR LOCK	101 115	S5	249	77834323	SPRING	295	S9

Top-Down Assembly/Component Parts List (Cont.)

ITEM NO	IDENT NO	DESCRIPTION	WHERE USED		ITEM NO	IDENT NO	DESCRIPTION	WHERE USED		
			USED	SH				USED	SH	
250	93592482	SCR HEX HD	101	115	S5	324	75893025	MOUNT	169	S8
251	77832458	OPTICAL SWITCH	125	127	S8	325	77603100	ARM-HEAD LOAD	281	318
252	75293954	CONNECTOR	125		S8	326	77830482	HOLDER-PAD ASSY	281	318
252	75293954	CONNECTOR	168		S8	327	10127321	SCR PAN HD	295	S9
253	94245602	CONTACT	125	127	S8	329	77830998	PIN CARRIAGE	281	318
253	94245602	CONTACT	168		S8	330	77830999	SPRING TORSION	281	318
254	10125759	SCREW FLAT HD	168		S8	331	94047068	WASHER, SPECIAL	281	318
255	10127131	SCREW	152		S4	332	75889161	LATCH DOOR	161	S9
256	10125805	LOCK WASHER	152		S4	333	10127310	SCREW SLOTTED	281	318
257	83460400	HOLDER PAD	326		S6	334	10125001	SCREW HEX HD	137	138
258	93592164	SCR HX SELF TAP	125		S8	335	94047000	WASHER	TWA	S3
258	93592164	SCR HX SELF TAP	127		S8	336	93592160	SCREW, SELF TAP	101	115
259	77835305	LABEL	168		S8	336	93592160	SCREW, SELF TAP	114	128
260	75791600	MOUNT	147		S8	337	93464000	WIRE BLACK	102-128	S7
261	75724402	SWITCH	147		S8	338	83435511	CONTACT PIN	139	S7
262	75293956	CONNECTOR	127		S8	338	83435511	CONTACT PIN	139	S7
263	83402301	LATCH-DOOR INJEC MOL	132-135		S9	339	10126401	STAR LOCK WASHER	101	115
263	83402301	LATCH-DOOR INJEC MOL	170		S9	340	75731302	ELECTRICAL SYMBOL	101	115
263	83402301	LATCH-DOOR INJEC MOL	150		S10	341	10126400	WASH EXT TOOTH LK	161	170
264	77594403	MOUNT	168		S8	341	10126400	WASH EXT TOOTH LK	131-136	S9
265	77834318	LEVER-DOOR	161		S9	341	10126400	WASH EXT TOOTH LK	150	S10
266	92096099	PIN-GROOVED	131-136		S9	342	77594800	DECAL	152	S4
266	92096099	PIN-GROOVED	161	170	S9	343	77833531	MOTOR PULLEY ASSY	110	S7
266	92096099	PIN-GROOVED	150		S10	344	75724543	CONNECTOR PANEL MTG	124	S7
267	75292700	KNOB-LEVER	132-136		S9	345	75724586	CONNECTOR PANEL MTG	124	S7
267	75292700	KNOB-LEVER	170		S9	346	83426204	CARRIAGE HEAD ASSY	281	S6
267	75292700	KNOB-LEVER	150		S10	347	93464555	WIRE 16 GRN	124	S7
268	83401200	SPRING-LATCH	131-136		S9	348	75724587	CONTACT PIN	129	130
268	83401200	SPRING-LATCH	161	170	S9	349	51797214	LUG TERM RING CRIMP	129	130
268	83401200	SPRING-LATCH	150		S10	350	75724569	CONNECTOR PANEL MTG	129	130
269	83413406	SCR SET SOC HD 6-32	131-136		S9	351	75724585	CONNECTOR PANEL MTG	129	130
269	83413406	SCR SET SOC HD 6-32	161	170	S9	352	77833542	MOTOR PULLEY ASSY	139	S7
269	83413406	SCR SET SOC HD 6-32	150		S10	353	75724401	ACTUATOR SWITCH	101	115
271	75292701	KNOB-LEVER	161		S9	354	09000004	SCREW BIND HEAD	147	S8
272	83413404	SCREW-SELF LOCKING	131-136		S9	355	75885407	OPTICAL SWITCH	168	S8
272	83413404	SCREW-SELF LOCKING	161	170	S9	356	77833545	MOTOR PULLEY ASSY	139	S7
272	83413404	SCREW-SELF LOCKING	150		S10	357	77832410	PANEL FRONT BLK-BURR	131	S9
273	83426621	PANEL FRONT, BLACK HW	133		S9	358	83426205	CARRIAGE HEAD ASSY	318	S6
274	75812121	DOOR, FINISHED, PA-BLK	133		S9	359	77830977	LATCH DOOR	131	S9
275	83426622	PANEL FRONT, WHITE HW	134		S9	360	75886086	BASE-MECHANISM, DIE	101	S4
276	75812122	DOOR, FINISHED, PA-WHT	134		S9	361	83403601	SPINDLE	101	115
277	83426623	PANEL FRONT, FIN BLUE	135		S9	362	75747000	SPACER BEARING	101	115
278	75812123	DOOR, FINISHED, PA-BLU	135		S9	363	75745200	PULLEY-SPINDLE	101	115
279	83461110	FRONT PANEL FINISHED	136		S9	364	75886087	BASE-MECHANISM, DIE	115	S4
280	75747801	STEPPER MOTOR ASM	137	138	S6	365	83461800	CLAMP, STEPPER MOTOR	101	115
281	77839902	CARRIAGE ASM	137		S6	366	75292400	GUIDE-CARRIAGE	101	115
283	75881371	SHIM	131		S9	368	75812021	SUPPORT-ASSEMBLED	101	S5
284	77594000	SPRING-CARRIAGE	137	138	S6	369	83402803	ARM-DISK LOAD	101	S5
285	75896352	DOOR LEVER SPRING	161		S9	370	75273000	PIN DISK LOAD ARM	101	115
286	10126209	SCR-SOC HP CAP	281	318	S6	371	75881370	LEVER DOOR	131	S9
287	75812124	DOOR FINISHED BLACK	132	136	S9	372	77832119	BUTTON LATCH	131	S9
287	75812124	DOOR FINISHED BLACK	131	161	S9	373	77835304	LABEL	324	358
287	75812124	DOOR FINISHED BLACK	150		S10	374	94277400	TIE STRAP	125	127
288	75813000	RETAINER-BEARING	137	138	S6	375	83427303	NUT CARRIAGE	137	138
289	92073020	BEARING FLANGED	137	138	S6	376	75812022	SUPPORT-ASSEMBLED	115	S5
290	94217207	BRG BALL-EXT INNER R	137	138	S6	377	93592486	SCREW	101	115
291	93529001	WASHER-SPRING WAVE	137	138	S6	378	95862300	ANCHOR CABLE TIE	161	S9
292	83403202	BAR TORSION DOOR	131-136		S9	378	95862300	ANCHOR CABLE TIE	150	S10
292	83403202	BAR TORSION DOOR	161	170	S9	379	77835132	SPACER BKT	295	S9
292	83403202	BAR TORSION DOOR	150		S10	380	77835226	MOTOR PULLEY ASSY	128	S7
293	83461111	FRONT PANEL	161		S9	381	77833531	MOTOR PULLEY ASSY	128	S7
293	83461111	FRONT PANEL	150		S10	382	77833525	MOTOR PULLEY ASSY	129	S7
294	77832456	LUBRICANT	137	138	S6	383	77833535	MOTOR PULLEY ASSY	129	S7
295	77835133	DOOR LK ASSY	161		S9	384	77833527	MOTOR PULLEY ASSY	130	S7
296	91976207	SCREW	161		S9	385	77833532	MOTOR PULLEY ASSY	130	S7
297	77833702	HARNES DR LK	161		S9	386	10125102	SCR NUT HEX	168	S8
298	75810703	RETAINING RING	161		S9	387	10126100	WASH INT TOOTH LK	168	S8
298	75810703	RETAINING RING	150		S10	388	10125603	WASHER	101	115
299	75810701	DIODE LIGHT	161		S9	388	10125603	WASHER	101	115
299	75810701	DIODE LIGHT	150		S10	389	83402804	ARM-DISK LOAD	115	S5
300	83461200	LATCH DOOR	136		S9	390	77833529	MOTOR PULLEY ASSY	114	S7
301	77830975	ADAPTER	152		S4	391	77833534	MOTOR PULLEY ASSY	114	S7
302	83401500	BUSHING-DOOR INJECT	131-136		S9					
302	83401500	BUSHING-DOOR INJECT	161	170	S9					
302	83401500	BUSHING-DOOR INJECT	150		S10					
303	75746000	LEVER-DOOR	132-136		S9					
303	75746000	LEVER-DOOR	170		S9					
303	75746000	LEVER-DOOR	150		S10					
304	75746800	BRACKET LATCH	131-136		S9					
304	75746800	BRACKET LATCH	161	170	S9					
304	75746800	BRACKET LATCH	150		S10					
305	77833526	MOTOR PULLEY ASSY	110		S7					
306	83460701	PAD HEAD LOAD	326		S6					
307	77830550	SOLID STATE RELAY	156		S8					
308	10127334	SCREW	156		S8					
309	10125105	NUT	156		S8					
310	75790803	SHAFT	171		S5					
311	83426400	EXPANDER-CONE	171		S5					
312	77830481	CONE-DISK LOAD	171		S5					
313	83402200	SPRING CONE	171		S5					
314	92033029	RETAINING RING	171		S5					
315	83409701	SPRING-GARTER	171		S5					
316	94047069	WASHER	171		S5					
317	94047070	WASHER	171		S5					
318	77839901	CARRIAGE ASSY	138		S6					
319	77833505	MOTOR PULLEY ASSY	113		S7					
320	75812011	SUPPORT DIE CAST MACHINED	368		S5					
321	75292807	BEARING-CYLINDRICAL	368		S5					
322	75813201	BUSHING, PUSH ROD MOLDED	368		S5					
323	75813202	BUSHING, PUSH ROD MOLDED	368		S5					

Cross Reference List

ITEM NO	SH	ITEM NO	SH	ITEM NO	SH	ITEM NO	SH
354	S8	162	S3	330	S6	346	S6
197	S5	149	S3	372	S9	358	S6
198	S5	304	S9	188	S4	311	S5
199	S4	304	S9	357	S9	273	S9
200	S5	304	S10	294	S6	275	S9
334	S6	362	S4	251	S8	277	S9
386	S8	173	S5	152	S3	195	S9
309	S8	141	S3	152	S4	211	S9
388	S4	280	S6	227	S7	375	S6
388	S5	244	S7	226	S7	125	S3
187	S4	244	S7	220	S7	125	S8
254	S8	244	S7	221	S7	210	S4
178	S4	183	S4	319	S7	234	S7
178	S5	184	S4	228	S7	234	S7
186	S4	231	S6	224	S7	234	S7
186	S5	231	S7	222	S7	234	S7
186	S8	231	S7	223	S7	236	S7
256	S4	231	S7	230	S7	236	S7
387	S8	231	S7	382	S7	338	S7
286	S6	310	S5	305	S7	338	S7
209	S4	137	S3	380	S7	101	S3
201	S5	137	S6	229	S7	101	S4
202	S4	138	S3	384	S7	101	S5
341	S9	138	S6	390	S7	148	S3
341	S9	260	S8	343	S7	257	S6
341	S10	248	S9	381	S7	306	S6
339	S4	299	S9	233	S7	279	S9
255	S4	299	S10	385	S7	293	S9
333	S6	298	S9	391	S7	293	S10
327	S9	298	S10	225	S7	300	S9
308	S8	320	S5	383	S7	365	S4
240	S7	368	S5	352	S7	296	S9
240	S7	376	S5	356	S7	314	S5
240	S7	274	S9	297	S9	193	S5
241	S7	276	S9	246	S9	194	S5
241	S7	278	S9	265	S9	194	S5
241	S7	287	S9	249	S9	289	S6
196	S4	287	S9	175	S5	191	S4
158	S3	287	S10	174	S5	191	S5
214	S8	215	S9	160	S3	266	S9
213	S8	288	S6	161	S3	266	S9
349	S7	322	S5	161	S9	266	S10
238	S7	323	S5	245	S9	126	S3
238	S7	371	S9	379	S9	208	S4
239	S7	283	S9	295	S9	337	S7
239	S7	109	S3	189	S5	347	S7
239	S7	109	S7	373	S6	291	S6
145	S3	108	S3	259	S8	192	S4
370	S5	108	S7	164	S3	247	S9
172	S5	128	S3	318	S6	237	S8
124	S3	128	S7	281	S6	216	S9
124	S7	129	S3	130	S7	216	S9
102	S3	129	S7	268	S9	216	S10
102	S7	130	S3	268	S9	205	S4
111	S3	218	S4	268	S10	205	S5
111	S7	177	S6	302	S9	336	S3
103	S3	217	S9	302	S9	336	S4
103	S7	217	S9	302	S10	203	S9
113	S3	217	S10	132	S3	203	S9
113	S7	176	S5	132	S9	203	S10
107	S3	355	S8	133	S3	258	S8
107	S7	360	S4	133	S9	258	S8
104	S3	364	S4	134	S3	155	S3
104	S7	332	S9	134	S9	250	S5
105	S3	115	S3	135	S3	377	S4
105	S7	115	S4	135	S9	219	S4
106	S3	115	S5	136	S3	335	S6
106	S7	324	S8	136	S9	331	S6
366	S4	285	S9	131	S3	316	S5
181	S5	204	S9	131	S9	317	S5
182	S5	150	S3	170	S3	290	S6
267	S9	150	S10	170	S9	190	S4
267	S9	235	S10	151	S3	253	S8
267	S10	284	S6	151	S9	253	S8
271	S9	264	S8	171	S5	374	S8
321	S5	168	S5	313	S5	122	S3
180	S4	168	S8	263	S9	122	S9
252	S8	169	S3	263	S9	122	S10
252	S8	169	S8	263	S10	212	S5
262	S8	342	S4	369	S5	378	S9
353	S5	147	S3	389	S5	378	S10
261	S8	147	S8	292	S9		
344	S7	325	S6	292	S9		
350	S7	312	S5	292	S10		
351	S7	326	S6	142	S3		
345	S7	146	S3	143	S3		
348	S7	307	S8	361	S4		
340	S4	156	S3	144	S3		
243	S7	156	S8	315	S5		
243	S7	140	S3	20	S5		
243	S7	127	S3	272	S9		
242	S7	127	S8	272	S9		
242	S7	179	S5	272	S10		
363	S4	301	S4	269	S9		
303	S9	359	S9	269	S9		
303	S9	157	S3	269	S10		
303	S10	329	S6	206	S5		