

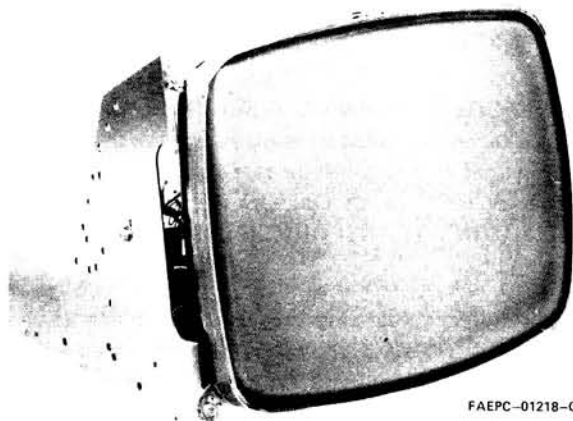

MOTOROLA



FAEPC-01218-0

Model MD3570-MD3574 Series - Chassis Version

GENERAL INFORMATION

These Motorola Series of CRT Display Monitors are available in two configurations. The chassis version, MD3570-74, has all components mounted on a lightweight metal chassis; the kit version, MD3970-74, is delivered with the CRT packed in a polystyrofoam cradle. The kit's circuit card is flexibly mounted in its shipping carton to allow the unit to be field installed to meet the particular installation requirements.

CAUTION

NO WORK SHOULD BE ATTEMPTED ON ANY EXPOSED MONITOR CHASSIS BY ANYONE NOT FAMILIAR WITH SERVICING PROCEDURES AND PRECAUTIONS.

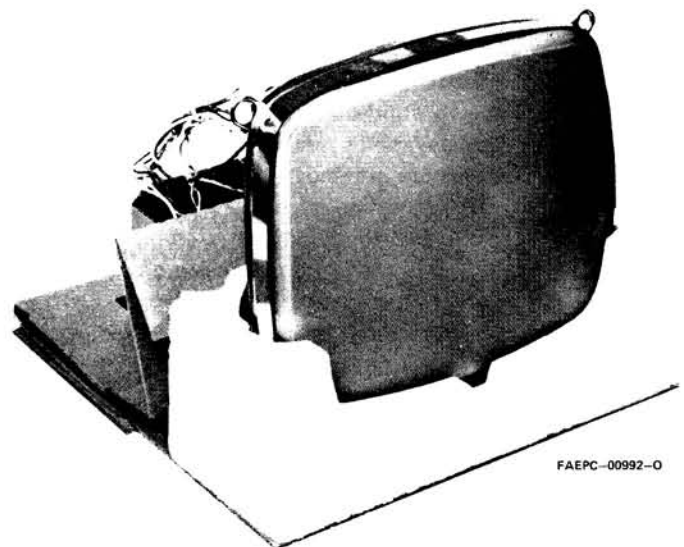

FAEPC-00992-0

Model MD3970-MD3974 Series - Kit Version

TABLE OF CONTENTS

GENERAL INFORMATION	1	HORIZONTAL SIZE ADJUSTMENT	5
SPECIFICATIONS	3	VIDEO/RASTER CENTERING ADJUSTMENT	5
DESCRIPTION	4	RASTER GEOMETRY ADJUSTMENTS	6
SERVICE NOTES		THEORY	
CIRCUIT TRACING	4	VIDEO AMPLIFIER	8
COMPONENT REMOVAL	4	HORIZONTAL DRIVE AMPLIFIER & OSCILLATOR	9
CRT REPLACEMENT	4	HORIZONTAL DRIVER & OUTPUT	9
OPERATIONAL CHECK/ADJUSTMENT PROCEDURES		HORIZONTAL OUTPUT TRANSFORMER	10
GENERAL	4	VERTICAL DRIVE	10
EQUIPMENT REQUIRED	4	PARTS LIST	12
BRIGHTNESS/CONTRAST ADJUSTMENT	5	SCHEMATIC DIAGRAM	13
VERTICAL HOLD ADJUSTMENT	5	INSTALLATION INSTRUCTIONS FOR	
FOCUS ADJUSTMENT	5	MD3970-74 MONITOR KITS	15
VERTICAL SIZE/LINEARITY ADJUSTMENT	5		



MOTOROLA INC.

Display Systems

SAFETY WARNING

CAUTION: NO WORK SHOULD BE ATTEMPTED ON AN EXPOSED MONITOR CHASSIS BY ANYONE NOT FAMILIAR WITH SERVICING PROCEDURES AND PRECAUTIONS.

1. **SAFETY PROCEDURES** should be developed by habit so that when the technician is rushed with repair work, he automatically takes precautions.
2. A **GOOD PRACTICE**, when working on any unit, is to first ground the chassis and to use only one hand when testing circuitry. This will avoid the possibility of carelessly putting one hand on chassis or ground and the other on an electrical connection which could cause a severe electrical shock.
3. Extreme care should be used in **HANDLING THE PICTURE TUBE** as rough handling may cause it to implode due to atmospheric pressure (14.7 lbs. per sq. in.). Do not nick or scratch glass or subject it to any undue pressure in removal or installation. When handling, safety goggles and heavy gloves should be worn for protection. Discharge picture tube by shorting the anode connection to chassis ground (not cabinet or other mounting parts). When discharging, go from ground to anode or use a well insulated piece of wire. When servicing or repairing the monitor, if the cathode ray tube is replaced by a type of tube other than that specified under the Motorola Part Number as original equipment in this Service Manual, then avoid prolonged exposure at close range to unshielded areas of the cathode ray tube. Possible danger of personal injury from unnecessary exposure to X-ray radiation may result.
4. An **ISOLATION TRANSFORMER** should always be used during the servicing of a unit whose chassis is connected to one side of the power line. Use a transformer of adequate power rating as this protects the serviceman from accidents resulting in personal injury from electrical shocks. It will also protect the chassis and its components from being damaged by accidental shorts of the circuitry that may be inadvertently introduced during the service operation.
5. Always **REPLACE PROTECTIVE DEVICES**, such as fishpaper, isolation resistors and capacitors and shields after working on the unit.
6. If the **HIGH VOLTAGE** is adjustable, it should always be **ADJUSTED** to the level recommended by the manufacturer. If the voltage is increased above the normal setting, exposure to unnecessary X-ray radiation could result. High voltage can accurately be measured with a high voltage meter connected from the anode lead to chassis.

7. **BEFORE RETURNING A SERVICED UNIT**, the service technician must thoroughly test the unit to be certain that it is completely safe to operate without danger of electrical shock. **DO NOT USE A LINE ISOLATION TRANSFORMER WHEN MAKING THIS TEST.**

In addition to practicing the basic and fundamental electrical safety rules, the following test, which is related to the minimum safety requirements of the Underwriters Laboratories should be performed by the service technician before any unit which has been serviced is returned.

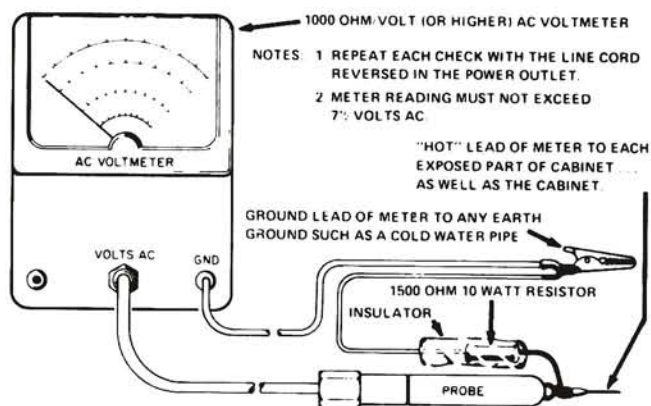

Voltmeter Hook-up for Safety Check

A 1000 ohm per volt AC voltmeter is prepared by shunting it with a 1500 ohm, 10 watt resistor. The safety test is made by contacting one meter probe to any portion of the unit exposed to the operator such as the cabinet trim, hardware, controls, knobs, etc., while the other probe is held in contact with a good "earth" ground such as a cold water pipe.

The AC voltage indicated by the meter may not exceed 7½ volts. A reading exceeding 7½ volts indicates that a potentially dangerous leakage path exists between the exposed portion of the unit and "earth" ground. Such a unit represents a potentially serious shock hazard to the operator.

The above test should be repeated with the power plug reversed, when applicable.

NEVER RETURN A MONITOR which does not pass the safety test until the fault has been located and corrected.

MD3570-74 & MD3970-74 SERIES 12" CRT DISPLAY MODULES

. ITEM	SPECIFICATION
Cathode Ray Tube:	12" measured diagonally (305 mm); 74.86 square inches (483 sq. cm); 90° deflection angle; integral implosion protection; P4 phosphor standard
Power Input:	+12VDC at 1.2 amps typical, 1.5 amps maximum
TTL Level Direct Drive Input Signals:	2.0 to 4.0V P-P Horizontal: 5μSec to 40 μSec positive-going drive Vertical: 50μSec to 15 mSec negative-going sync (positive-going optional) Video: positive white, 2.5V typical (2.0 to 4.0V PP)
Video Response:	Bandwidth within 3 dB, 10 Hz to 26 MHz typical
Horizontal Blanking Interval:	10 microseconds minimum (includes retrace and delay)
High Voltage:	12.5 kV typical
Scanning Frequency:	MD3570-74 and MD3970-74 from 15.7 kHz \pm 300 Hz to 20.7 kHz \pm 300 Hz Vertical 47-63 Hz
Resolution:	900 lines center, typical; 750 lines corner (P4 Phosphor)
Geometric Distortion:	within 2% measured with standard EIA ball chart and dot pattern
Linearity:	within 10% measured with standard EIA ball chart and dot pattern
Controls:	Internal - horizontal size, vertical size, vertical linearity, focus, internal brightness, vertical hold and horizontal phase (video-centering). Provisions for an additional remote (operator) brightness control (500K), and customer supplied contrast control (500 ohms nominal.)
Unit Weights:	MD3970-74 (all models) 11½ lbs. (5.18 Kg.) MD3570-74 (all models) 13½ lbs. (6 Kg.)
Environment:	Operating temperature: 0°C to +55°C Storage temperature: -40°C to +65°C Note: Models with bonded etched panels should not be subjected to storage or operating temperatures above 50°C. Operating altitude: 10,000 ft. maximum (3048 meters) Designed to comply with applicable DHEW rules on X-Radiation, and CSA Spec. Designed to enable listing under UL Specification 478

In a continual effort to upgrade our standard products as new technological advances are made, specifications are subject to change without notice.

DESCRIPTION

All models in this manual are electrically similar and employ direct drive. All signal development is accomplished externally to the monitor and applied to the individual video, horizontal drive, and vertical drive inputs.

They are fully transistorized (except the CRT) and are designed for alphanumeric display. A 12" CRT of the magnetic deflection type is used, which has integral implosion protection. These CRT monitors require a power input of +12 volts DC @ 1.2 amperes.

Input and output connections are made through a 10-pin circuit card edge connector. Provision is made for an optional customer supplied, remote brightness and/or contrast controls.

Circuit card components are mounted only on one side, with foil circuitry on the reverse side of the card. Schematic reference numbers are printed on both sides of the circuit card to help locate and identify components when servicing.

Circuitry consists of two stages of video amplification, five stages of horizontal deflection processing, and one stage of vertical deflection processing.

SERVICE NOTES

CIRCUIT TRACING

Component reference numbers are printed on the top and bottom of the three circuit cards to facilitate circuit tracing. In addition, control names are also shown and referenced on the schematic diagram in this manual.

Transistor elements are identified as follows:

E – emitter, B – base, and C – collector

COMPONENT REMOVAL

Removing components from an etched circuit card is facilitated by the fact that the circuitry (copper foil) appears on one side of the circuit card only.

A solder extracting gun is recommended for component removal. An iron with a temperature controlled heating element is also desirable since it reduces the possibility of damaging the circuit card foil due to over-heating.

The nozzle of the solder extracting gun is inserted directly over the component lead and when sufficiently heated, the solder is drawn away leaving the lead free from the copper foil. This method is particularly suitable in removing multi-terminal components.

CRT REPLACEMENT

General

Use extreme care in handling the CRT as rough handling may cause it to implode due to high vacuum pressure. Do not nick or scratch glass or subject it to any undue pres-

sure in removal or installation. Use goggles and heavy gloves for protection. In addition, be sure to disconnect the monitor from all external voltage sources.

Procedure

- Step 1. Connect a grounding strap (first) to a metal chassis for a good earth ground; then discharge CRT by shorting the H.V. 2nd anode to ground.
- Step 2. Remove the CRT socket, deflection yoke (loosen clamp screw) and 2nd anode lead connector.
- Step 3. Carefully remove CRT from the front of the chassis by loosening and removing four (4) screws, one (1) at each corner of the CRT.
- Step 4. Reverse steps 2 and 3 to install the new CRT.
- Step 5. After installation perform the following Operational Check/Adjustment Procedures.

OPERATIONAL CHECK/ADJUSTMENT PROCEDURES

GENERAL

The following procedures are provided to check the operation of the monitor and perform simple preinstallation adjustments (if required), or readjust after servicing and component replacement.

When reference is made to adjust to a specific size display (vertically and horizontally), refer to original model specifications for correct dimensions by the monitor model number. This also applies to minimum and maximum tolerances when adjusting for correct CRT geometry, linearity, focus, etc.

– NOTE –

To assist in understanding more of the preceding terminology, refer to a separate Motorola Manual, "Incoming Inspection Guide" (Motorola part number 68P25253A71).

Perform the procedures in the sequence presented, and allow at least five (5) minutes warm-up before adjusting the monitor. In addition, when instructed to disconnect an input signal, do not ground the signal at the circuit card edge connector (P1). This action could damage the signal source generator. Instead, disconnect the signal at its source.

CCW = Counter Clockwise Rotation, CW = Clockwise Rotation. (As viewed from rear of circuit card.)

EQUIPMENT REQUIRED

- Regulated 12VDC Power Supply
- Precision Digital Voltmeter
- Non-Metallic Alignment Tool
- Test Signals (Bench test signals must be same ampli-

tude, polarity, and frequency as final installed operating signal source. Refer to original specifications for values by monitor model number.)

The following Motorola gauges are required for performing complete and accurate CRT geometry and linearity alignment. Refer to original model specifications for correct gauges to use.

Linearity Gauge Slot Gauge Parallelogram Gauge

BRIGHTNESS/CONTRAST ADJUSTMENT

Procedure:

- Step 1A. Disconnect video signal input (only) from pin 8 of edge connector P1 . . .
- or
- Step 1B. If monitor is equipped with a Contrast control (R116 on the monitor circuit card or customer supplied off-circuit card), rotate to the position that cuts off the video input signal.
- Step 2. Rotate Master Brightness control (R110) fully CCW (raster off).
- Step 3. If present, rotate the CRT Brightness Cutoff control (R118) fully CW.
- Step 4. If present, rotate the Remote Brightness control fully CW.
- Step 5. Rotate Master Brightness control (R110) until the raster just begins to appear on the CRT; then back off slightly to the threshold of raster cutoff.
- Step 6A. Reconnect video signal. . .
- or
- Step 6B. Adjust Contrast control (if present) for desired video display level on CRT.
- Step 7. Rotate Remote Brightness control fully CCW; video display disappears.
- Step 8. Rotate CRT Brightness Cutoff control (R118) CCW until the video display just begins to appear on the CRT; then back off slightly to the threshold of video display cutoff.
- Step 9. Adjust Remote Brightness control for desired (overall) video display brightness level.

VERTICAL HOLD ADJUSTMENT

Procedure:

If video display is rolling, adjust the Vertical Hold control (R206) until the video display remains locked in.

FOCUS ADJUSTMENT

Procedure:

The optimum focus of the display is obtained by adjusting the Focus control, R318, for best focus at a point that is near the center and approximately 1/3 down from the top of the display.

VERTICAL SIZE/LINEARITY ADJUSTMENT

Procedure:

- Step 1. Adjust the Vertical Size control (R208) until the specified size display (vertically) is obtained.
- Step 2. (Refer to Figure 1.) Adjust the Vertical Linearity control (R211) until the extreme top and bottom characters (designated "A" and "B") are equal in height to the center characters (designated "C").
- Step 3. Readjust the Vertical Size control (R208), if necessary, for specified size display (vertically).

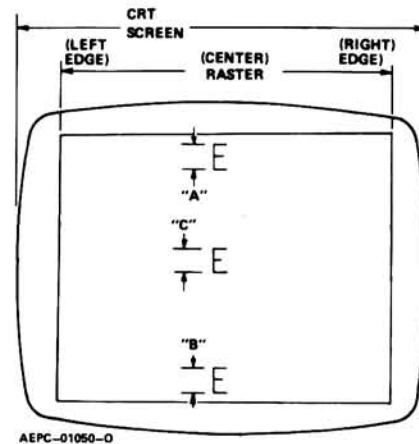

Figure 1. Partial CRT Display of Characters for Vertical Linearity Adjustment

HORIZONTAL SIZE ADJUSTMENT

Procedure:

- Step 1. Turn slug of Horizontal Width Coil, L303, clockwise (into the circuit card) to increase width, and counterclockwise to decrease width (away from the circuit card).
- Step 2. Adjust Horizontal Width Coil, L303 for specified width or for a proportionate display (approximately 6" high by 8½" wide).

VIDEO/RASTER CENTERING ADJUSTMENT

(Applicable only if the CRT and/or deflection yoke have been changed.)

General

This procedure should be performed while the monitor is free-standing on a bench, and in the correct sequence (preceding the Raster Geometry Adjustment procedures). Do not readjust after the monitor has been installed in a cabinet or terminal.

- Step 1. With a test signal applied to the monitor, increase the Brightness control until the raster becomes visible.
- Step 2. If necessary, adjust Vert. Size, R208, and Horiz.

Width, L303, so that all edges of the raster are visible.

- Step 3. Adjust Horizontal Centering control, R307, to position the video display equidistant from the left and right edges of the illuminated raster.
- Step 4. Position the centering magnets for best overall centering of the raster within the active phosphor area of the CRT.
- Step 5. Readjust the Vert. Size, R208, and Horiz. Width, L303, to specified dimensions.

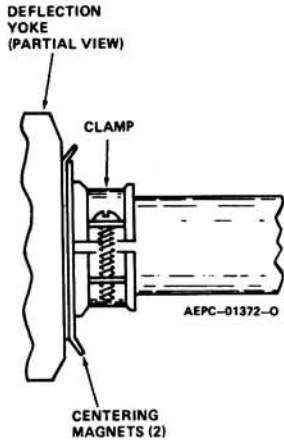

Figure 2. Partial View of CRT Neck/Deflection Yoke

RASTER GEOMETRY ADJUSTMENTS

General

This adjustment is normally required only if the yoke and/or CRT have been replaced. Upon completion of the geometry adjustments, there may not be a yoke magnet installed on every yoke mounting pin. Normal installation ranges from one to four yoke magnets per deflection yoke. In addition, keep in mind that there will be some interaction between yoke magnets on the deflection yoke mounting pins. Whereby, as the geometry adjustment proceeds, it may be necessary to remove an earlier positioned magnet from one pin when a new magnet is positioned (or added) on a different pin.

There are two (2) different strength yoke magnets available for correcting CRT geometry. The soft core (or flexible) magnet is the stronger of the two magnets. (Reference Figure 4 to identify their north poles.) Pincushion and trapezoidal correction generally require high strength magnets, and barrel correction requires a lower strength magnet for correction.

— WARNING —

High voltages are present at the deflection yoke and are a potential shock hazard. Exercise caution when performing the following adjustment procedures.

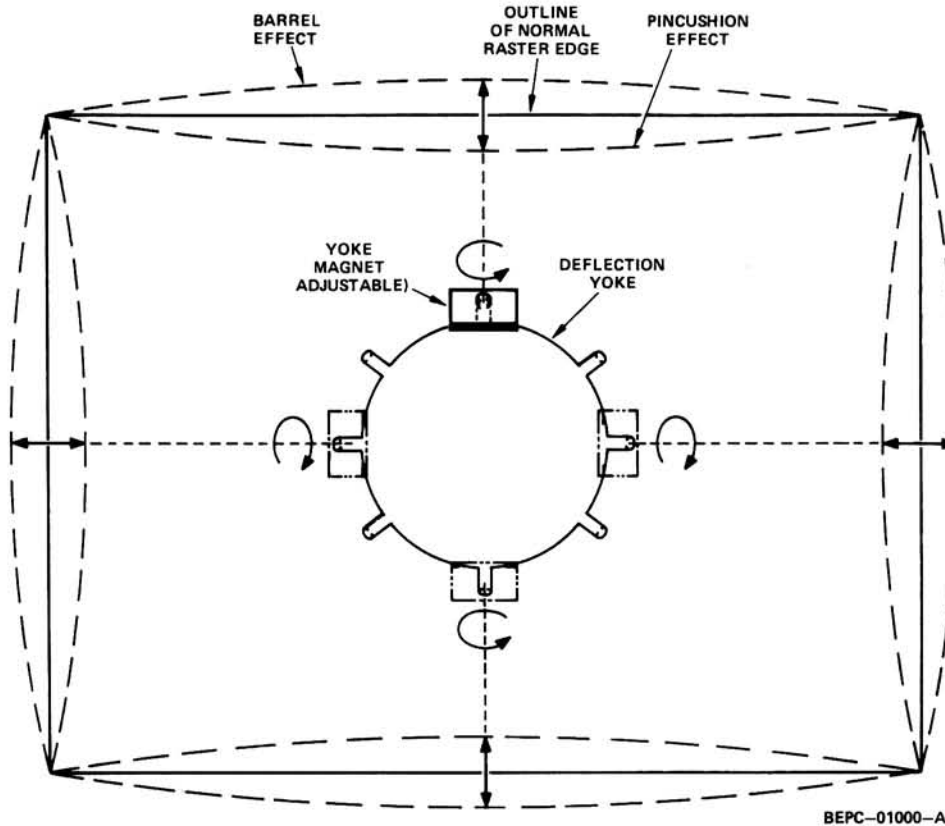

Figure 3. Pincushion/Barrel Effects and Adjustment

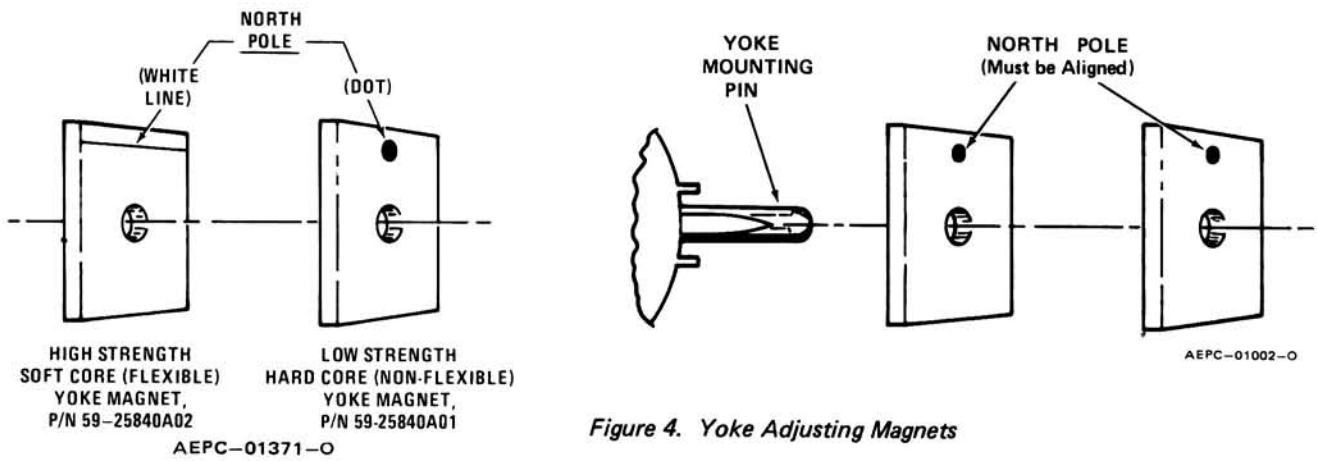

Figure 4. Yoke Adjusting Magnets

Pincushion/Barrel Correction (top, bottom and sides) Procedure:

Perform this adjustment if the raster exhibits the abnormal effects shown in Figure 3.

- Step 1. Push a magnet on the yoke mounting pin as shown in Figure 3. A magnet should be placed only on the pin that corresponds to the affected area.
- Step 2. Rotate the magnet to obtain the desired raster, labeled "NORMAL" on Figure 3.
- Step 3. If the desired raster cannot be obtained, add a second magnet to the yoke mounting pin. Both magnets must be aligned as shown in Figure 4; then rotated simultaneously.

Trapezoidal Correction (corners) Procedure:

Perform this adjustment if the raster exhibits the abnormal effects shown in Figure 5.

- Step 1. Push a magnet onto the yoke mounting pin as shown in Figure 5. Magnet should be placed only on the pin that corresponds to the affected area.
- Step 2. Rotate the magnet to obtain the desired raster, labeled "NORMAL" in Figure 5.
- Step 3. If the desired raster cannot be obtained, add a second magnet to the yoke mounting pin. Both magnets must be aligned as shown in Figure 4; then rotated simultaneously.

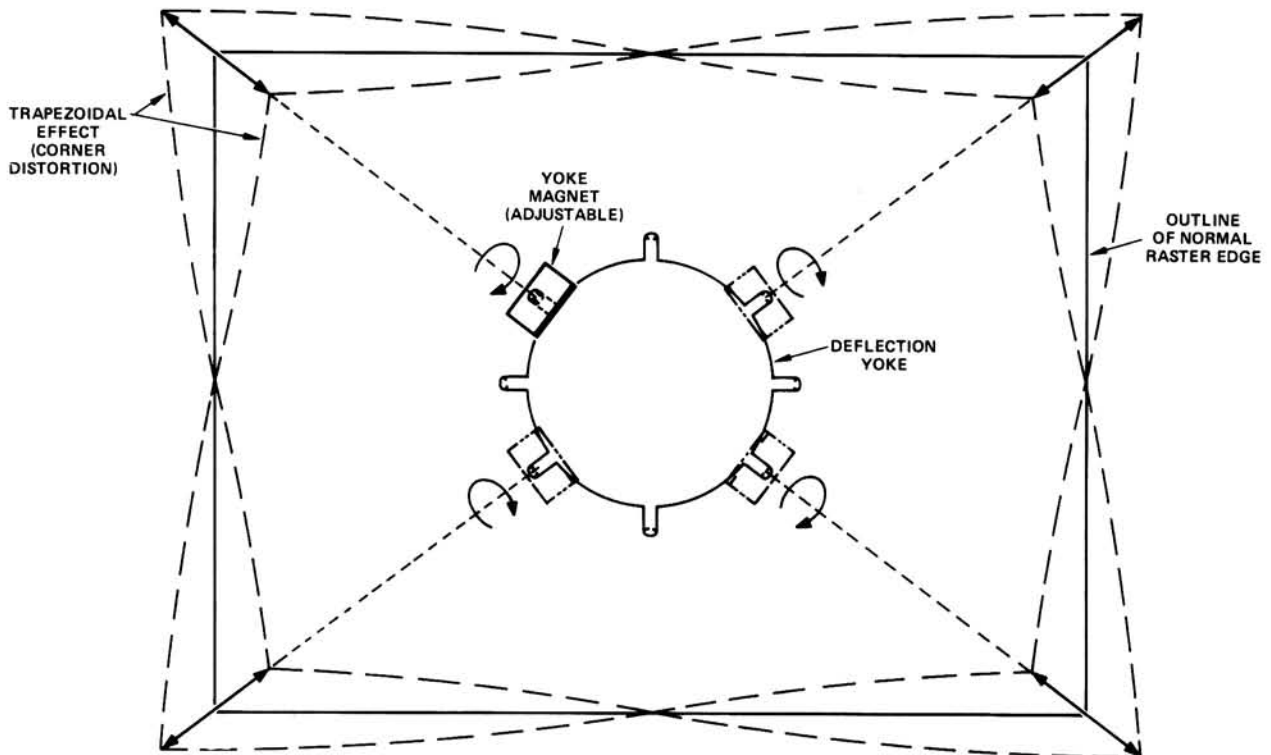

Figure 5. Trapezoidal Effect and Adjustment

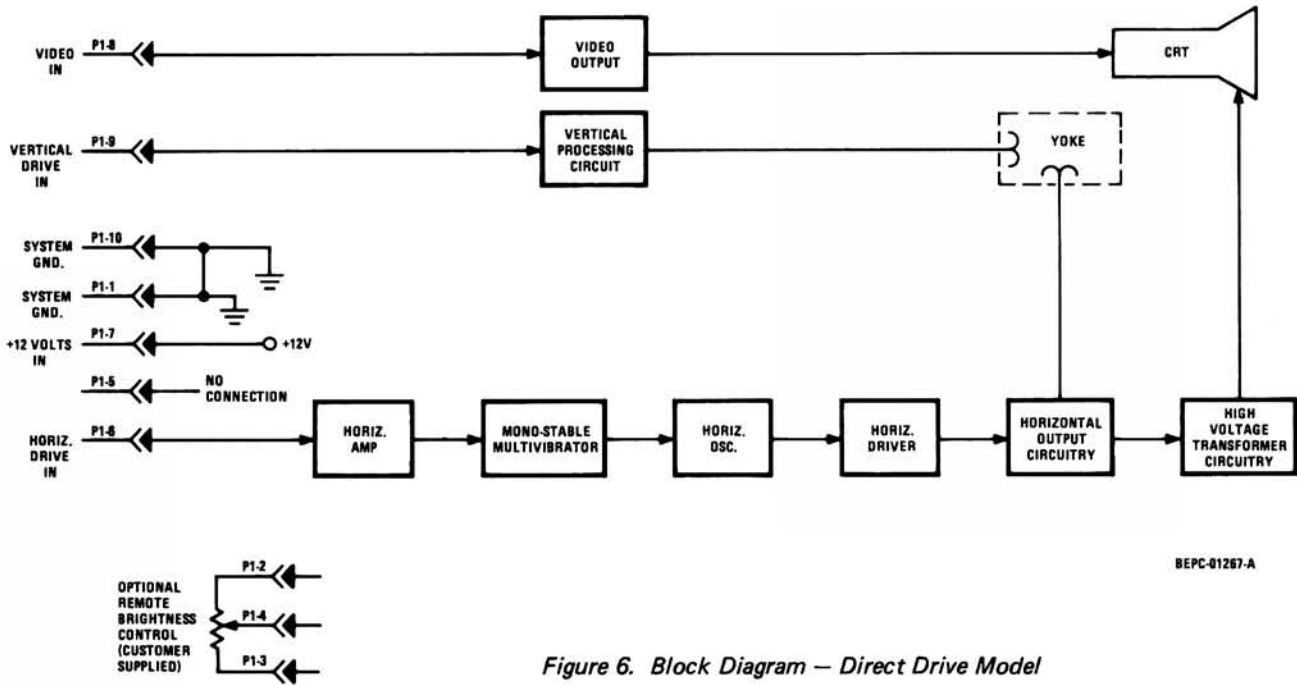

Figure 6. Block Diagram — Direct Drive Model

THEORY OF OPERATION

These Motorola Series CRT Monitors are direct drive units requiring separate video, horizontal drive and vertical drive inputs. All are TTL compatible. Power supplied to the monitor is +12V DC.

The monitor consists of a Video Amplifier, a Vertical Processing stage, and five stages of Horizontal Deflection (see Figure 6).

VIDEO AMPLIFIER (Refer to Figure 7)

The linear video amplifier consists of two stages, Q101 and Q102, which are connected in a cascode configuration. This common emitter-common base arrangement greatly reduces the effect of Miller capacity (when compared to a conventional single transistor video amplifier/output stage).

A TTL compatible non-composite video signal, approximately 3.0 volts P-P, is DC coupled to the base of Q102 via R102. R108 and C103 provide high frequency compensation to maintain a flat response when Q101 and Q102 conduct.

During a no-signal condition, video driver transistor Q102 is off. At the same time, video output transistor Q101, is base biased at 6V by voltage divider R103 and R104. When a video signal is applied to the base of Q102, it turns on, allowing Q101 to conduct. The resultant output is developed across collector load resistor R105 and DC coupled to the CRT cathode via resistor R109. Q101 is protected from CRT arcing by a spark gap built into the CRT socket, and R109 further isolates Q101 from transients. Capacitor C101 shorts video frequency signals from the base of Q101 to ground. Capacitor C102 provides additional filtering of the +68V supply.

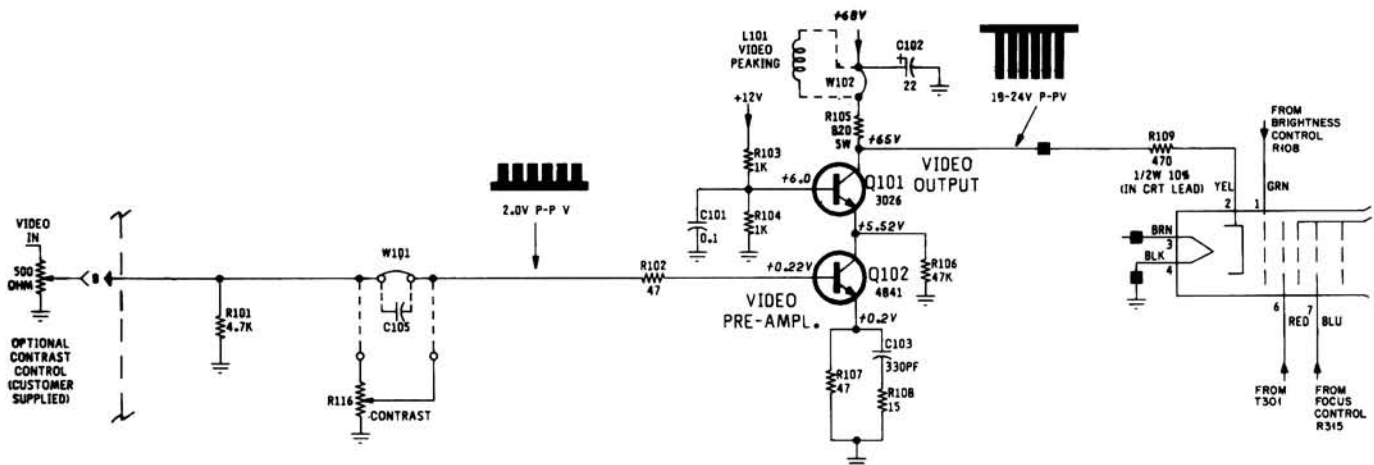

Figure 7. Video Amplifier Circuitry

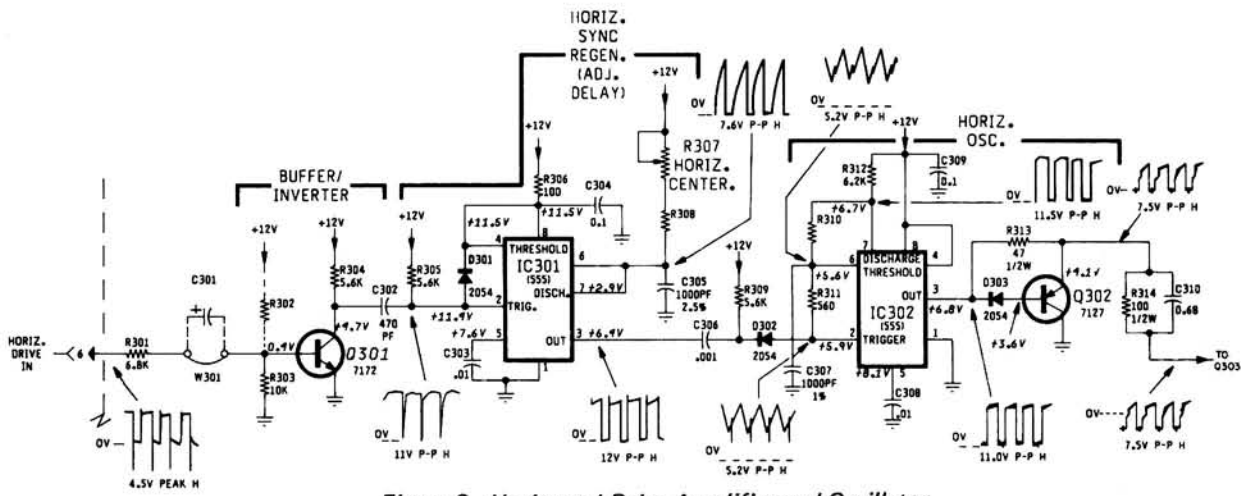

Figure 8. Horizontal Drive Amplifier and Oscillator

HORIZONTAL DRIVE AMPLIFIER AND OSCILLATOR (Refer to Figure 8)

Transistor Q301 is a single state horizontal drive amplifier which operates as a switch. During a no-signal condition, Q301 is biased at cut-off. The horizontal drive input is DC coupled to the base of Q301. Positive-going horizontal drive pulses of 3.0 volts P-P will turn Q301 on and cause it to saturate. The inverted amplified output of Q301 is developed across resistor R304. These inverted pulses of approximately 11 volts P-P, pass through a differentiator circuit consisting of C302 and R305. This shapes the pulses into sharp spikes which are applied to the input (pin 2) of IC301.

Diode D301 clamps the input signal to +12 volts. IC301 is a timer IC used in a mono-stable multivibrator mode to delay the incoming drive pulse approximately one horizontal scan line. This delay is made variable (via R307) to center the video information on the CRT. Components R307, R308 and C305 form an RC network which determine the amount of delay. This delay has a range of 1/2 to 1 1/2 horizontal scan lines. Capacitor C304 provides local filtering for IC301.

The 12 volt P-P non-symmetrical output of IC301 (pin 3) passes through a differentiator circuit consisting of C306 and R309. The differentiator produces positive and negative going spikes which are applied to diode D302. D302 couples only the negative-going spikes to the input of IC302 (pin 2).

IC302 is used as an oscillator that free-runs above the horizontal synchronized input frequency. If a loss of the horizontal drive signal occurs, the oscillator will free-run at a higher frequency reducing the high voltage developed by the flyback transformer. This prevents any destruction of components in the horizontal output circuitry. Components R310, R311, R312 and C307 determine the free-running frequency of the oscillator. Capacitor C309 provides local filtering for IC302. The output of IC302 (pin 3) is an 11 volt P-P non-symmetrical square wave.

HORIZONTAL DRIVER AND OUTPUT (Refer to Figure 9)

When the output of IC302 (Pin 3) goes high, horizontal output transistor Q303 is forward biased via R313, R314 and C310 causing it to "turn-on." At this time horizontal

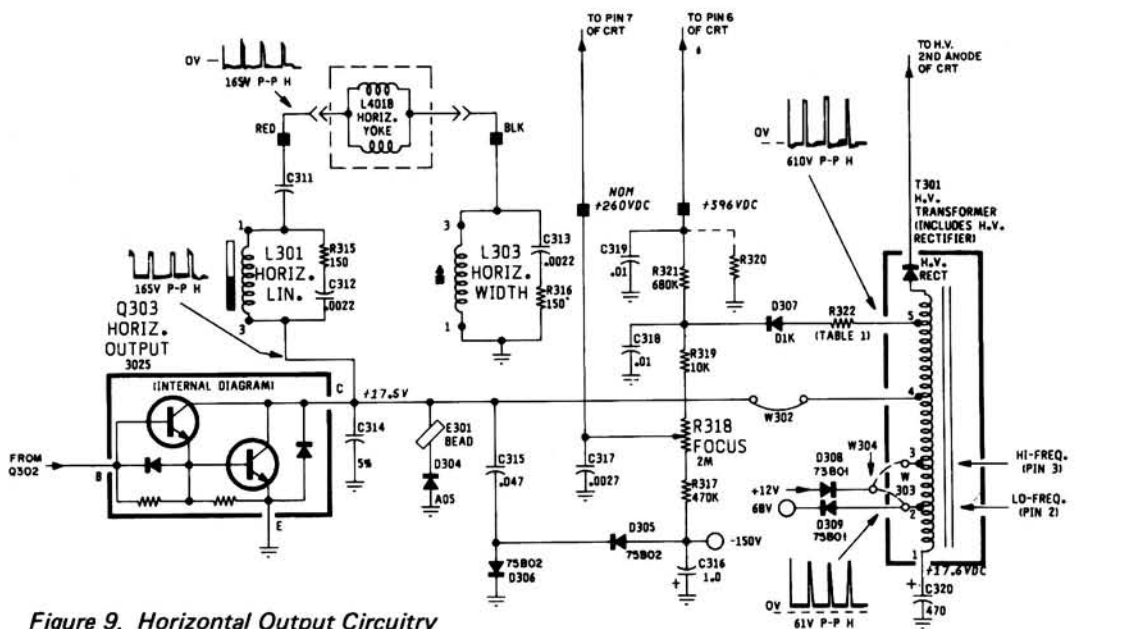

Figure 9. Horizontal Output Circuitry

driver transistor Q302 is reverse biased and is cut off. Diode D303 protects Q302 from reverse base-emitter voltage.

When the output of IC302 goes low, Q302 turns on, drawing current through R314 and C310 which turns Q303 off. RC network R314 and C310 is a speed-up network used to increase the collector switching time of Q303.

HORIZONTAL OUTPUT TRANSFORMER (Refer to Figure 9)

The horizontal output transistor, Q303, is simply a switch which is turned on and off at the horizontal scan rate by the driving signal applied to its base. A sawtooth current through the deflection coils is required to sweep the beam linearly across the CRT screen. The sweep begins at the center of the CRT and sweeps to the right. This happens when Q303 is turned on and its collector voltage drops to near zero. C314 begins discharging through the deflection coils which deflect the beam to the right edge of the CRT. At this time, Q303 cuts off and C314 ceases to supply current to the deflection coils. However, an induced voltage appears across the deflection coil as the magnetic field collapses and an oscillation then occurs between the deflection coils and C314.

During the first half cycle of this oscillation, the induced voltage is felt across the collector of now cut off Q303, C314 and the primary of T301 - the flyback transformer. This voltage is stepped up by T301 and rectified to produce the required high voltage that is applied to the 2nd anode at the CRT. The electron beam is also deflected to the left edge of the CRT at this time because the collapsing magnetic field of the deflection coils reverses polarity.

During the second half cycle of the deflection coils/C314 oscillation, the voltage on the collector of still cut off Q303 becomes negative. At this time, damper diode D304 becomes forward biased and begins conduction. The deflection coil current gradually decreases to zero during damper conduction allowing the beam to sweep linearly to the center of the screen.

Focus voltage for the CRT is derived from the auto-transformer action of T301. D307 and C318 form a positive voltage source. This voltage is reduced by R321 and filtered

further by C319 to supply the second grid, G2, of the CRT. During auto-transformer action time, D306 conducts, charging C315 negative to positive. When the yoke field collapses, C315 discharges through D305 and places a negative charge on C316. This creates the -150 volt source for the brightness circuit. The focus pot (R318) varies the focus voltage in a limited range provided by the voltage divider resistors R319 and R317. Coil L301 is a magnetically biased linearity coil that shapes the deflection current for optimum trace linearity. Coil L303 is a series horizontal width control. Components R315 and C312, C313 and R316 are damping network components for the horizontal linearity (L301) and width (L303) coils.

VERTICAL DRIVE (Refer to Figure 10)

The vertical deflection circuit consists of one stage, IC201, which accomplishes all active vertical drive functions. Vertical input pulses are differentiated by C201 and R202. This allows IC201 to be edge sensitive. R201 provides proper input loading. Diode D201 couples only the negative-going spikes from the differentiator circuit to the sync input of IC201 (Pin 8). R203 and R204 provide input current limiting. The sync input (Pin 8) performs several functions. It strips away any random noise that may be present on the input line and conditions the vertical pulses for processing. It also converts the input voltage pulses to current to control the internal oscillator. The oscillator generates a non-symmetrical square wave with a short duty cycle at approximately 60 Hz. Components R205, R206 and C202 determine the frequency. This square wave signal is applied to a ramp generator whose slope and amplitude is determined by R207, R208, and C203. The ramp voltage signal is applied to a buffer stage which isolates the ramp generator from the output stages and reduces any loading effect on the previous stages. Components R209, R210, R211, C204, and C205 reshape the ramp voltage to make it extremely linear.

The output signal from the buffer stage is applied to a pre-amp stage for amplification and then to a power amp stage which drives the vertical deflection coils directly via coupling capacitor C210. Components R216 and C209 provide damping to prevent any oscillations in the output circuit. R213, R214, R215, R217, R218, C206, C207 and C208 provide AC and DC feedback for the output stage to maintain proper gain and linearity.

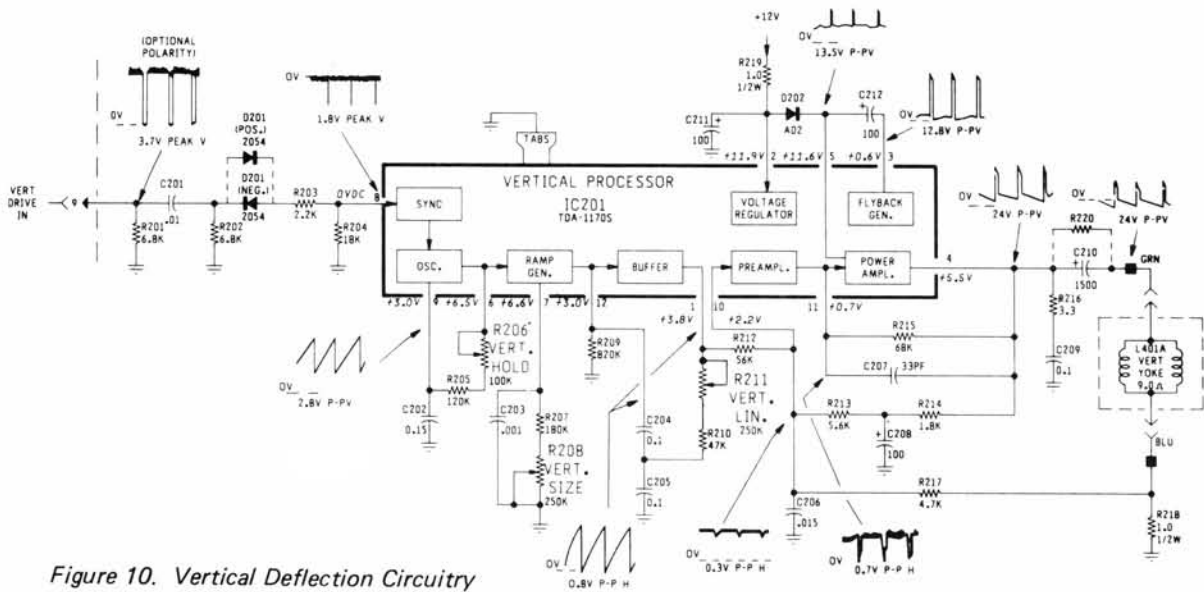

Figure 10. Vertical Deflection Circuitry

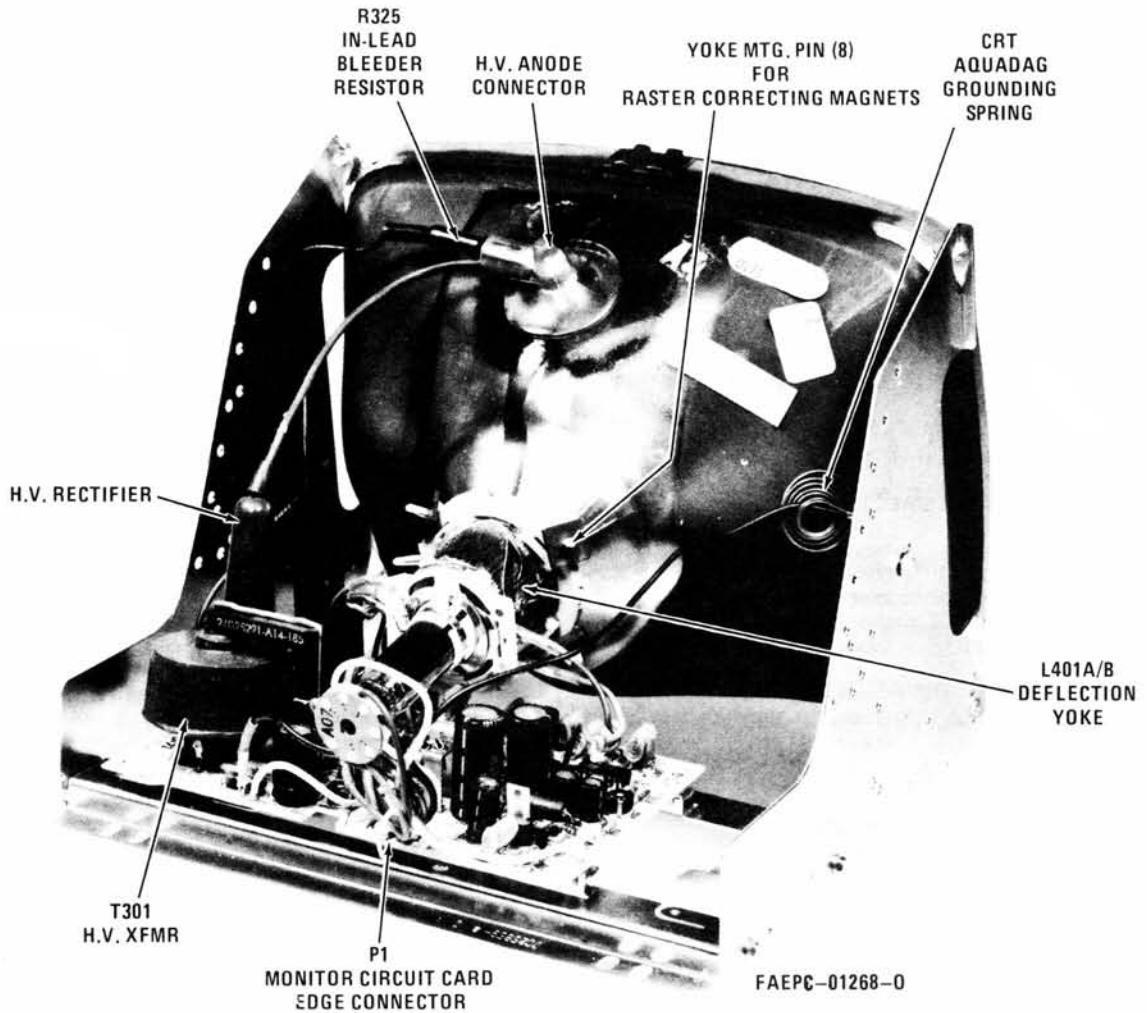

Figure 11. Model MD3570-74 Series Chassis Version, Rear View

REPLACEMENT PARTS LIST

REF. NO.	PART NO.	DESCRIPTION	REF. NO.	PART NO.	DESCRIPTION
CAPACITORS: (All values are in microfarads unless otherwise noted.)			TRANSISTORS:		
C101	8R29959A77	0.1 10% 200V Poly.	Q101	48R03026A00	Transistor, 3026
C102	23R29914B49	22 100V Lytic	Q102	48R134841	Transistor, 4841
C103	21S131625	330 10% X5F 500V Disc	Q301	48R137172	Transistor, 7172
C104	8R29959A65	.047 10% 200V Poly.	Q302	48R00137127	Transistor, 7127
C201	8R29959A42	.01 10% 400V Poly.	Q303	48R03025A00	Transistor, 3025
C202	8R22959A82	.15 10% 100V Poly.	IC201	51R06015A00	Vertical Proc.; TDA-1170S
C203	21S180851	.001 10% X5F 500V Disc	IC301,302	51R06332A00	Timer; 555
C204,205	8R29959A77	0.1 10% 200V Poly.	RESISTORS:		
C206	8R29959A46	.015 10% 100V Poly.	Note: Only power or special resistors are listed. Use the description when ordering standard values of fixed carbon resistors up to 2 watts.		
C207	21S180894	33 10% NPO 500V Disc	R105	17R29999A03	820 5% 5W
C208	23R29914A40	100 16V Lytic	R110	18D25904A02	Control Brightness 250K
C209	8R29959A77	0.1 10% 200V Poly.	R206	18D25904A04	Control Vertical Hold 100K
C210	23R29914A68	1500 125V Lytic	R208	18D25904A02	Control Vertical Size 250K
C211,212	23R29914A40	100 16V Lytic	R211	18D25904A02	Control Vertical Linearity 250K
C302	21S180852	470PF 10% X5F 500V Disc	R307	18D25904A08	Control HorizontalCentering 22K
C303	8R29959A42	.01 10% 400V Poly.	R310		33.2K 1% (MD2570-71/MD3970-71)
C304	8R29959A77	0.1 10% 200V Poly.			28.0K 1% (MD3573-74/MD3973-74)
C305	8R29970A03	.001 2.5% 100V Polyprop.	R318	18D25245A32	Control Focus 2 Meg.
C306	21S180851	.001 10% X5F 500V Disc	R325	6R29978A01	240 Meg. 20% 2W Cer.
C307	8R29970A02	.001 1% 100V Polyprop.	TRANSFORMERS:		
C308	8R29959A42	.01 10% 400V Poly.	T301	24D25291A14	Transformer, Horiz. Output MD3570-74
C309	8R29959A77	0.1 10% 200V Poly.	T301	24D25291A17	Transformer, Horiz. Output MD3970-74
C310	8R29959B05	.68 10% 100V Poly.	MISCELLANEOUS:		
C311	23R29910A04	10 25V Lytic (MD3573-74/MD3973-74)	- CRT REPLACEMENT NOTE -		
	23R29910A04	15 25V Lytic (MD3570-71/MD3970-71)	Order replacement CRT's by referring to the CRT Identification Label on the bell of the tube. There will be a manufacturers Type Number, and a Motorola Part Number that begins with a 96 prefix. If the label is not present, or legible, order the replacement CRT by the complete model number.		
C312,313	21S180C39	.0022 10% Z5F Disc	---	42D25298A04	Anode Connector
C314	8R29956A38	.039 5% 200V Mylar	---	9D25241A07	CRT Socket
		.047 5% 200V Mylar (MD3570-71/MD3970-71)	---	59B25840A01	Yoke Magnet
C316	23R29944A02	1 250V Lytic	---	41D65987A01	Aquadag Spring (M3573)
C317	21S180C41	.0027 10% Z5F 100V Disc	---	41B25685B01	Aquadag Spring (M3973)
C318,319	8R29959A42	.01 10% 400V Poly.	---	29-10134A71	Yoke Lead Term. Lugs
C320	23R29914A85	470 35V Lytic	---	29S10134A55	Aquadag & Bleeder Wire Lugs
C401	23R29914A48	2200 16V Lytic	---	84D25912A01	P.C. Panel
			---	26-25834B01	Heat Sink for Q4
DIODES/RECTIFIERS:			E301	76A25809A02	Ferrite Bead
D201	48R02054A00	Diode, 2054	P401	15S10183B06	Housing, Male
D202	48R191A02	Diode, 91A02		39S10184A83	Pin, Female
D301-303	48R02054A00	Diode, 2054	S401	15S10183B07	Housing, Female
D304	48R191A05	Diode, 91A05		39S10184A84	Pin, Male
D305,306	48R02075B02	Diode, B02			
D307	48R134978	Diode, D1K			
D308	48R02073B01	Diode, Fst. Recvry.			
D309	48R02075B01	Diode, B01			
COILS/CHOKES:					
L401A/B	24D25830A02	Yoke, Deflection			
L301	24D25600A15	Coil, Linearity			
L303	24D25603A16	Coil, Width			

- NOTE -

For replacement of components that differ in unique CRT display models, order replacement components by specifying the units model number, description of the component, and its schematic designator.

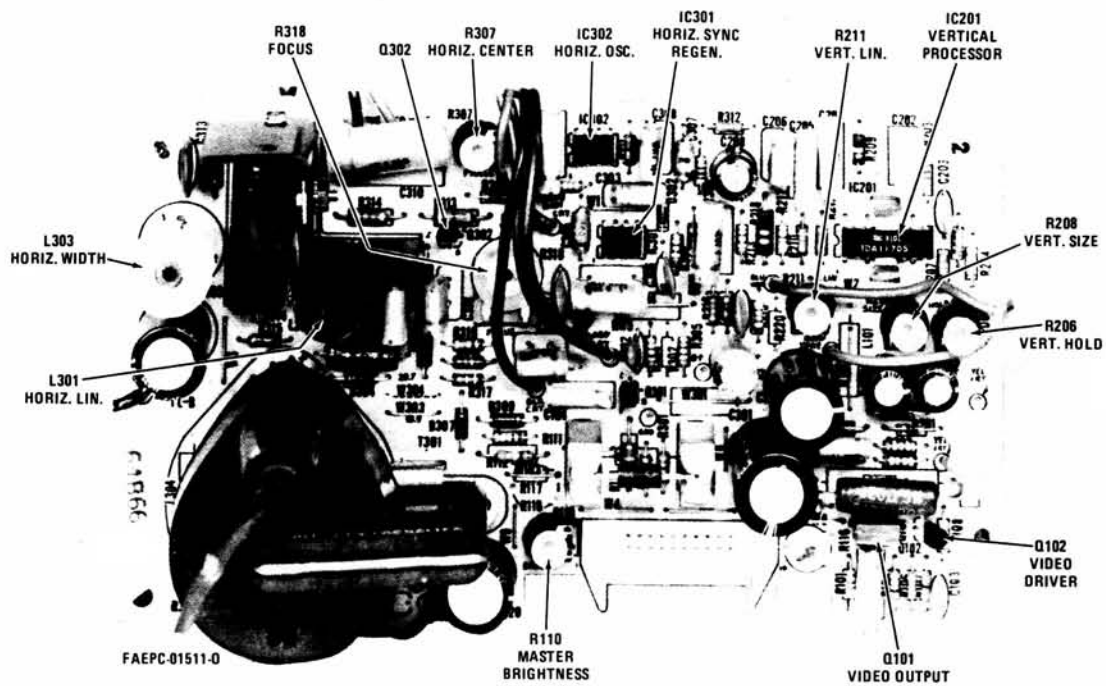

Model MD3570-4/MD3970-4 Series CRT Display Monitor Circuit Card, Component View (Current Version)

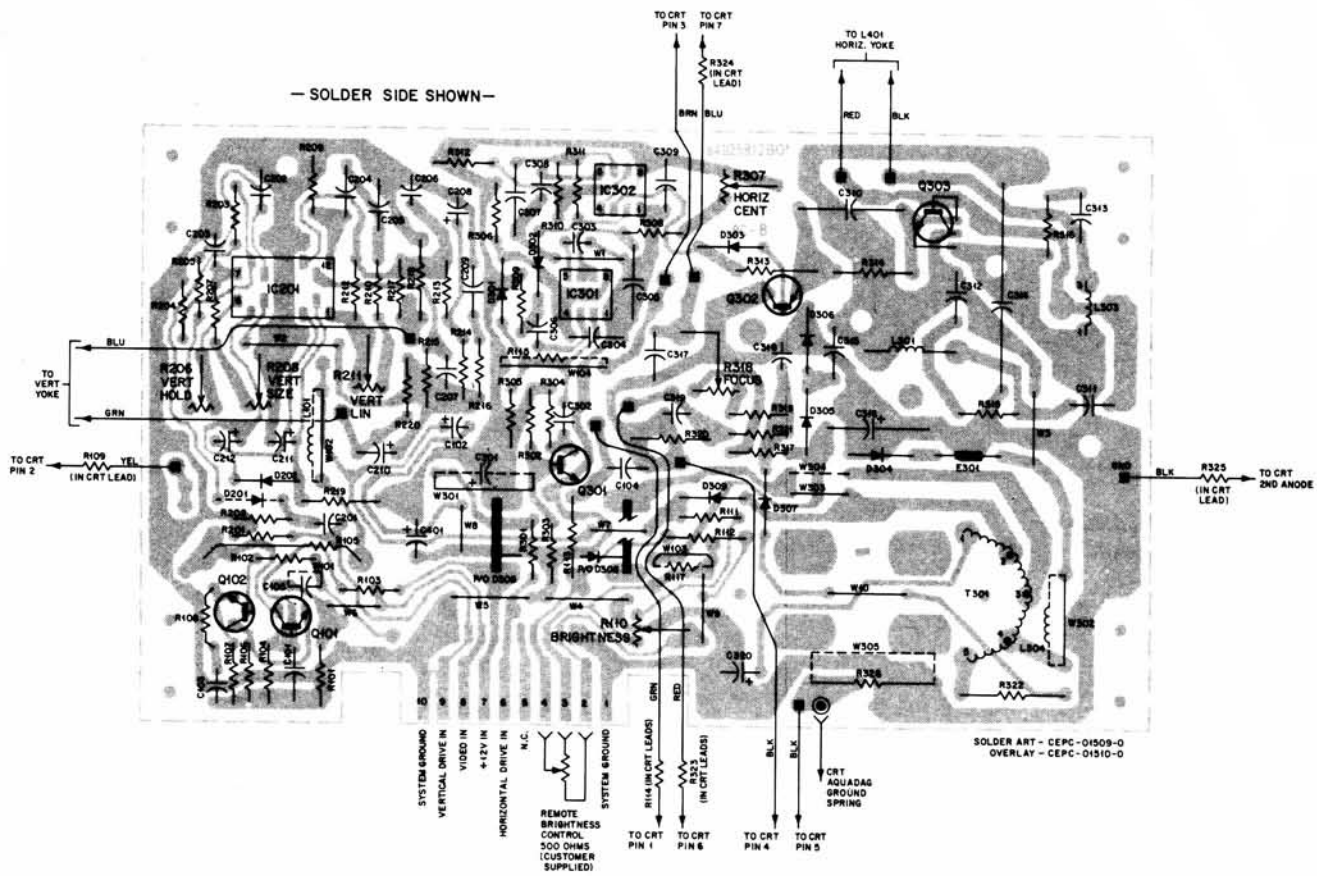

Model MD3570-4/MD3970-4 Series CRT Display Monitor Circuit Card Detail, Solder Side (Current Version)

TABLE 1 CRT RATIO VARIABLES

CRT RATIO	R115	R154	R270	R322
1"	3.4	IN	OUT	10K 10K 1.1W
9"	4.5	OUT	3.9K	1.8K 1.5K 1W
CRT	4.5	OUT	3.9K	1.8K 1.5K 1W

- LEGEND:**
- CIRCUIT CARD EDGE CONNECTION
 - ⊙ CIRCUIT CARD MALE PIN CONNECTION
 - ⊙ PLUGGY MALE PIN CONNECTION
 - SOCKET/TYPE FEMALE PIN CONNECTION
 - REPRESENTS SOURCE OF DISTRIBUTION POINT FOR VOLTAGE VALUE INDICATED.
 - ⊕— DC VOLTAGES MEASURED WITH INSTRUMENT COLORING CONNECTION TO POINTS SHOWN WITH VOLTAGE VALUE.
 - ⊕⊕ VOLTAGE VALUES MAY VARY ± 15%.
 - ⊕⊕⊕ VOLTAGE VALUES WITH ASSOCIATED CONTROL SETTINGS.
 - N.P., NON-POLARIZED CAPACITOR.

- NOTES:**
- UNLESS OTHERWISE SPECIFIED, ALL CAPACITORS ARE IN MICROFARADS, RESISTORS ARE 1/4W, 5%. REFERENCE TO PARTS LIST AND IDENTIFICATION OF COMPONENTS REFER TO PARTS LIST.
 - VOLTAGES MEASURED WITH CONTROLS SET FOR NORMAL OPERATION, INPUT SIGNALS AS SHOWN.
 - DC VOLTAGES MEASURED WITH VOLT.
 - WAVEFORMS TO BE TAKEN WITH OSCILLOSCOPE AT VERTICAL 1V OR HORIZONTAL 50K RATE AS SHOWN.
 - COMPONENTS ENCLOSED BY DASHED LINES ARE MOUNTED OFF CIRCUIT BOARD.
 - COMPONENTS LOCATED IN FRONT VOLUME LEADS.
 - IDENTIFIED COMPONENTS MAY NOT BE IN PLACE UNTIL ALL POINTS ARE CHECKED AND IDENTIFIED. SOME MAY BE AVAILABLE FOR VALUES.

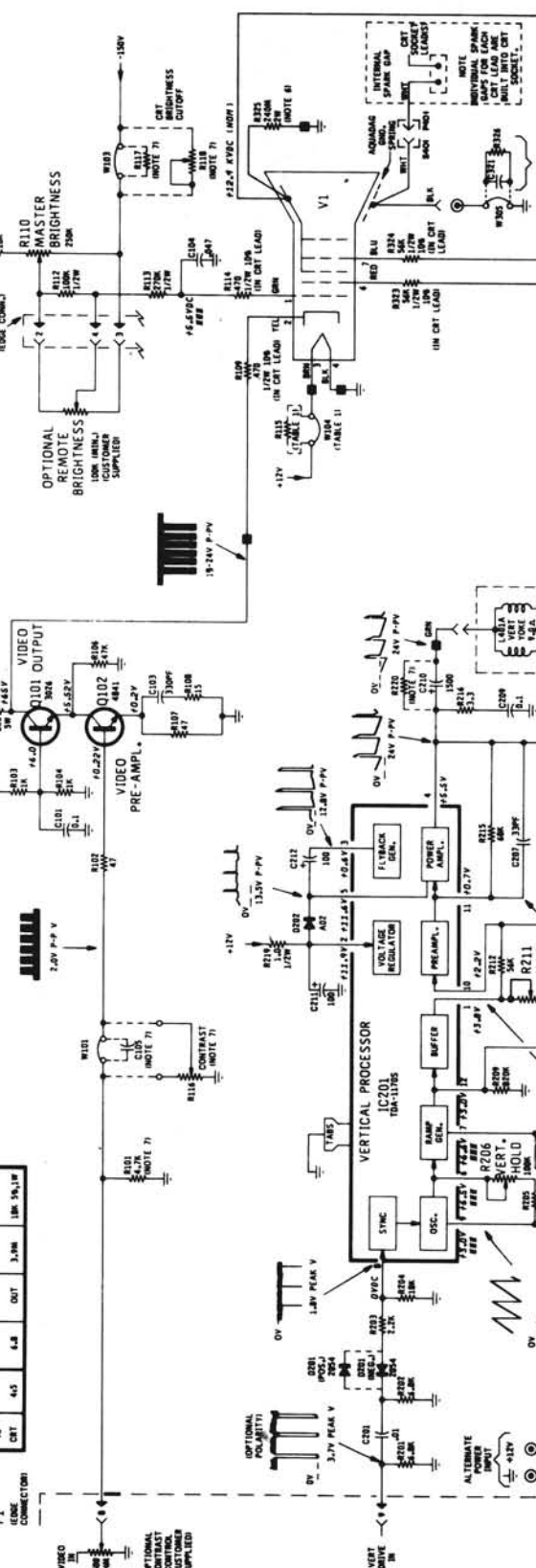
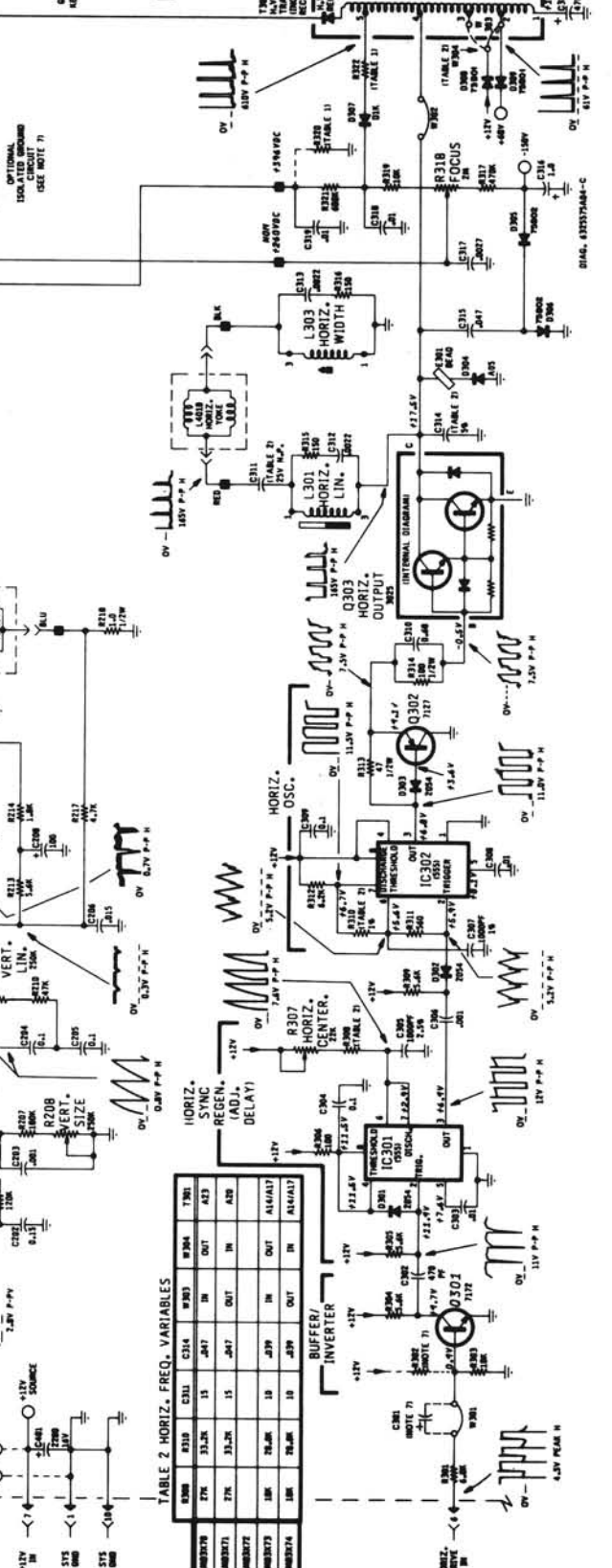
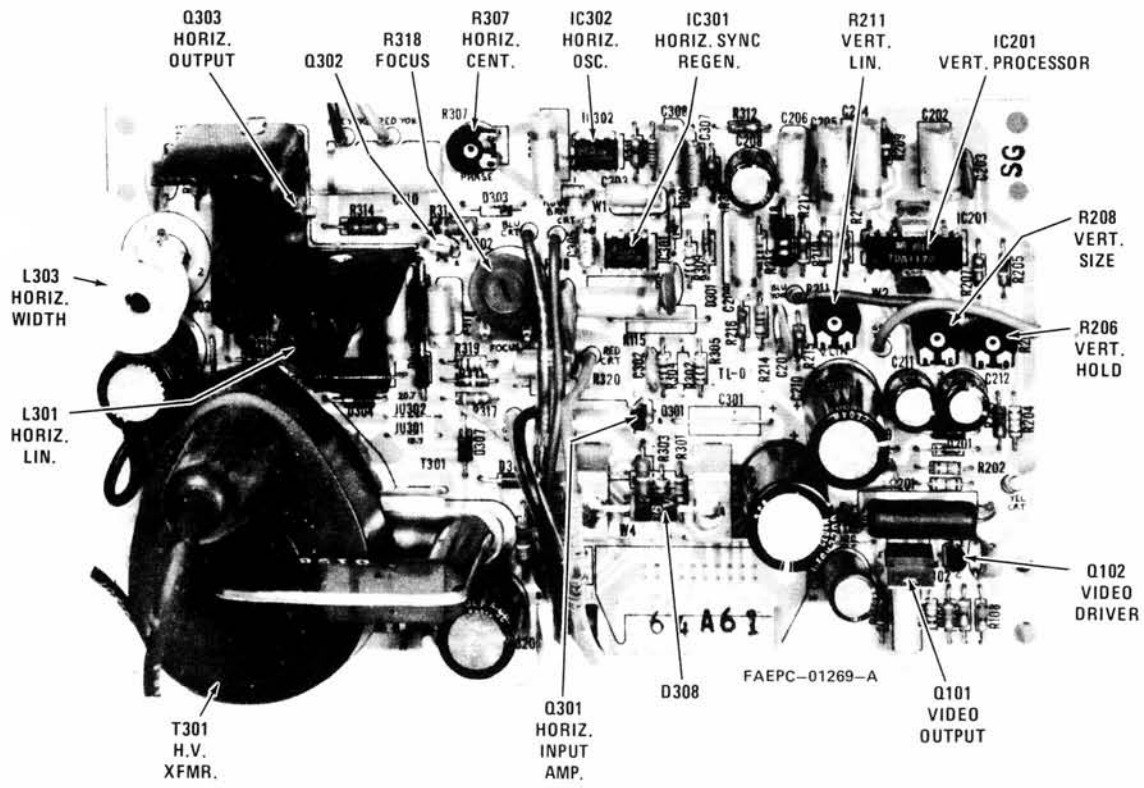

TABLE 2 HORIZ.-FREQ. VARIABLES

WAVEFORM	R310	R311	C314	R303	R304	T301
HORIZ. SYNC.	33.2K	15	.047	IN	OUT	A33
HORIZ. REGEN. (A.D.J.)	33.2K	15	.047	OUT	IN	A33
HORIZ. DELAY	18K	10	.039	IN	OUT	A14/A17
HORIZ. OSC.	18K	10	.039	OUT	IN	A14/A17





Model MD3570-4/MD3970-4 Series CRT Display Monitor Circuit Card, Component View (Early Version)

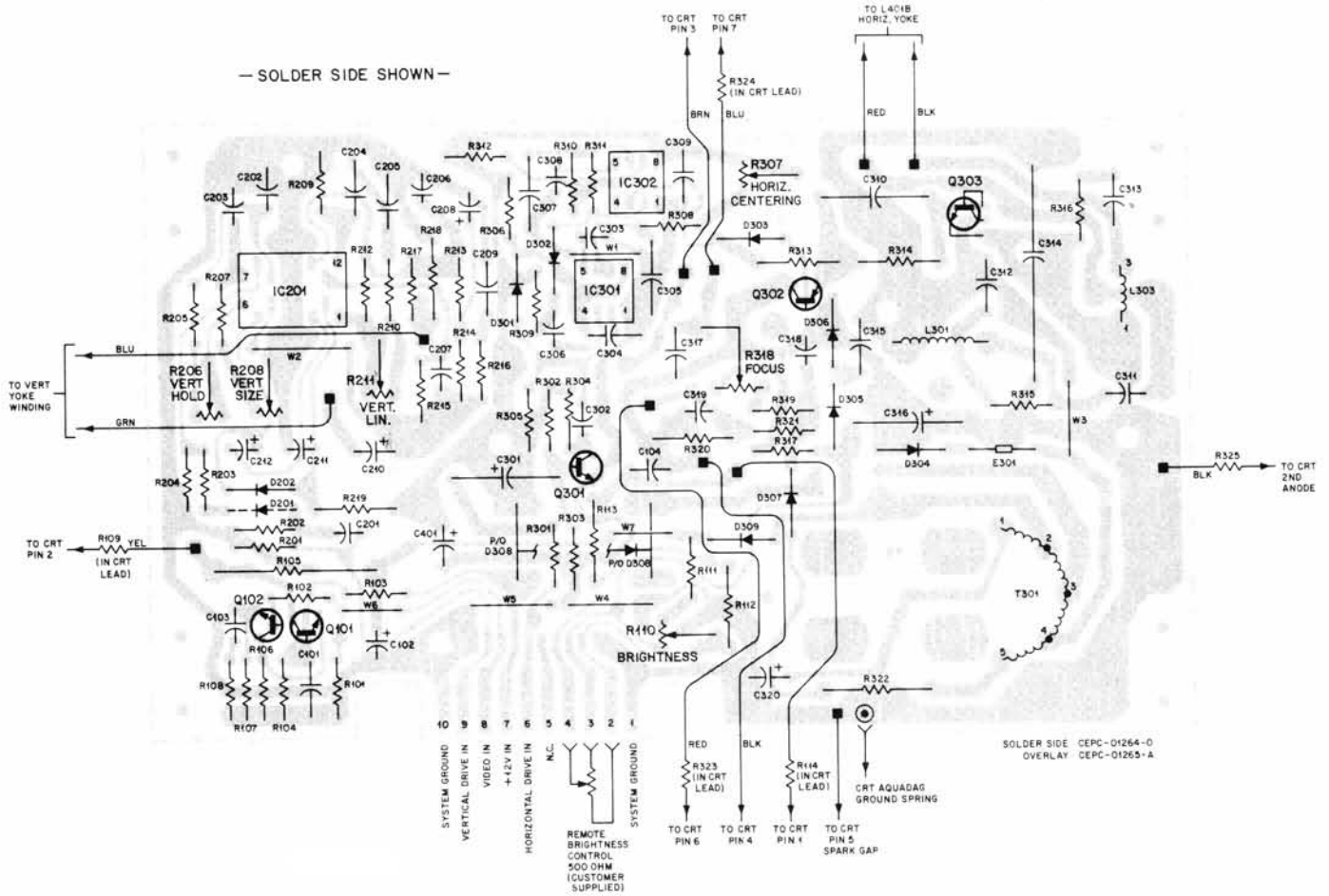

Model MD3570-4/MD3970-4 Series CRT Display Monitor Circuit Card Detail, Solder Side (Early Version)

Installation Instruction Section for MD3970-74 Monitor Kits

GENERAL

The Model MD3970-74 CRT Display Monitor kit may be installed into many different types of cabinets, housings, consoles, etc. As a result, it is not the intention of these brief installation instructions to describe the many installation possibilities. Instead, only installation limitations will be described. To ensure a proper installation, read the following paragraphs completely (before starting) to fully understand the various limitations.

For complete operation and maintenance information, which includes schematics, circuit card layout details, parts lists, photographs with parts identification/location, etc., use the front half of this manual.

— CAUTION —

NO WORK SHOULD BE ATTEMPTED ON ANY EXPOSED MONITOR KIT COMPONENTS BY ANYONE NOT FAMILIAR WITH PROPER SERVICING PROCEDURES AND PRECAUTIONS.

PRELIMINARY CHECKOUT

The 12-inch CRT and associated components, which make up the basic MD3970-74 kit, are mounted and shipped as shown in Figure 1. All components are properly interconnected for operation. Simply fabricate the mating plug for the edge connector on the rear of the monitor circuit card (see Figure 2).

To pretest the kit before final installation, remove the kit

from the shipping carton, or remove the kit from the pallet and open the cardboard shipping housing. (See Figure 1.)

— CAUTION —

A fire hazard exists if the monitor is operated in the shipping carton or on the cardboard shipping board for any length of time. Be sure adequate ventilation is available to keep the ambient temperature, in the monitor housing, below +55°C (+131°F).

12-INCH CRT

As with any glass envelope vacuum tube, the danger of implosion is always present if dropped or mishandled. Even though the CRT used in this kit has integral implosion protection, handle the CRT with extreme care, and wear safety glasses. In addition, do not carry the CRT by its neck or apply excessive pressure to it.

The CRT may be positioned in any manner desired. However, be sure that the anode cap has a minimum of 1-inch clearance from any metal shield, bracket, etc., and ½" clearance away from the bell and neck of the CRT.

To mount the CRT in its final operating location, use No. 8 type hardware and the holes in each corner of the CRT. After final installation, check to be sure that the CRT aquadag spring is positioned properly and grounded by the black wire to the monitor circuit card.

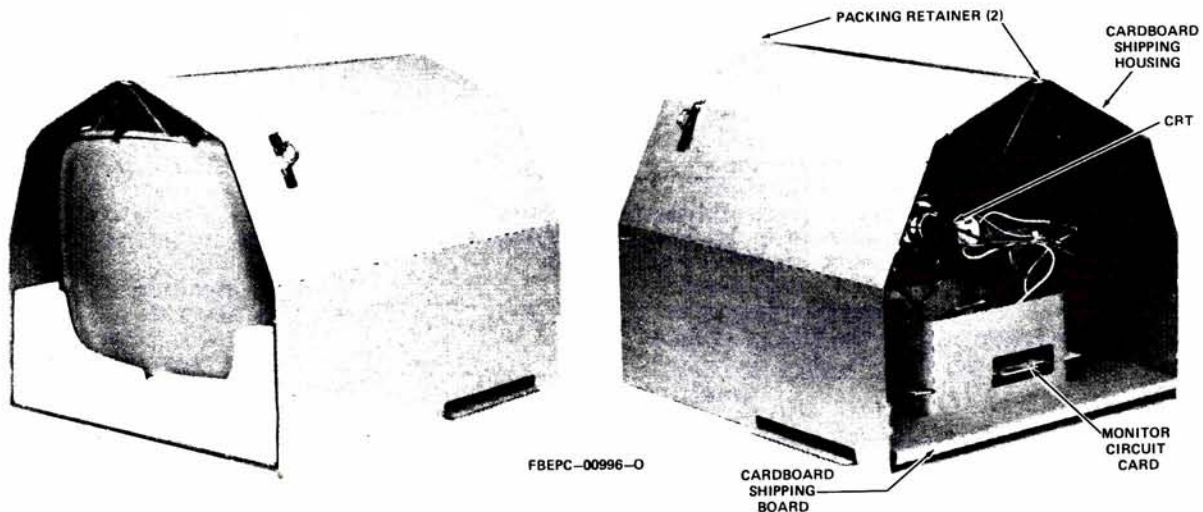

Figure 1. Model MD3970-74 Series Kit Version, Shipping Package (Front and Rear View)

MONITOR CIRCUIT CARD

The monitor circuit card may be mounted horizontally or vertically. A minimum of 5/16-inch clearance is required between the copper foil side of the circuit card and the mounting surface. In addition, a minimum of 2 inches is required above the circuit card for component clearance and access to all adjustable controls. Furthermore, it is desirable to place the High Voltage Transformer a minimum of three inches away from the Deflection Yoke.

Do not allow any wires to lay on top of, or alongside any power transistor heat sinks on the circuit card. High heat dissipation could melt the wire insulation. In addition, be sure the yellow wire (CRT cathode connection) from the circuit card to pin 2 of the CRT socket does not lay near any metal or horizontal circuitry.

Use four (4) No. 6 type screws and hardware, plus stand-offs, to secure the circuit card in its desired location.

Grounding of the monitor circuit card, to an external metal chassis ground connection depends on the overall system grounding of the monitor.

Refer to the ADJUSTMENTS outlined in front half of this manual and perform as necessary.

— NOTE —

At the time of the initial installation procedure, it will be necessary to perform the Raster (Geometry) Adjustment Procedures.

GENERAL SERVICING PRECAUTIONS

— CAUTION —

Before attempting to service the monitor, disconnect (or turn off) the external power supply; then, as an added precaution, discharge the CRT 2nd anode before handling any high voltage components. In addition, be sure to observe all safety warnings and service notes in the front of this manual.

When it is necessary to disconnect the deflection yoke, and/or CRT socket leads, pull their small female pins straight out without any back and forth rocking motion. This action will prevent, or at least minimize deforming male pins on the components and/or breaking their solder connections.

Use caution around the heat sink of the horizontal output transistor. The heat sink is at the same potential as the transistor collector. During normal operation with signal input present, the horizontal heat sink has 165 volt P-P pulses (with respect to system ground).

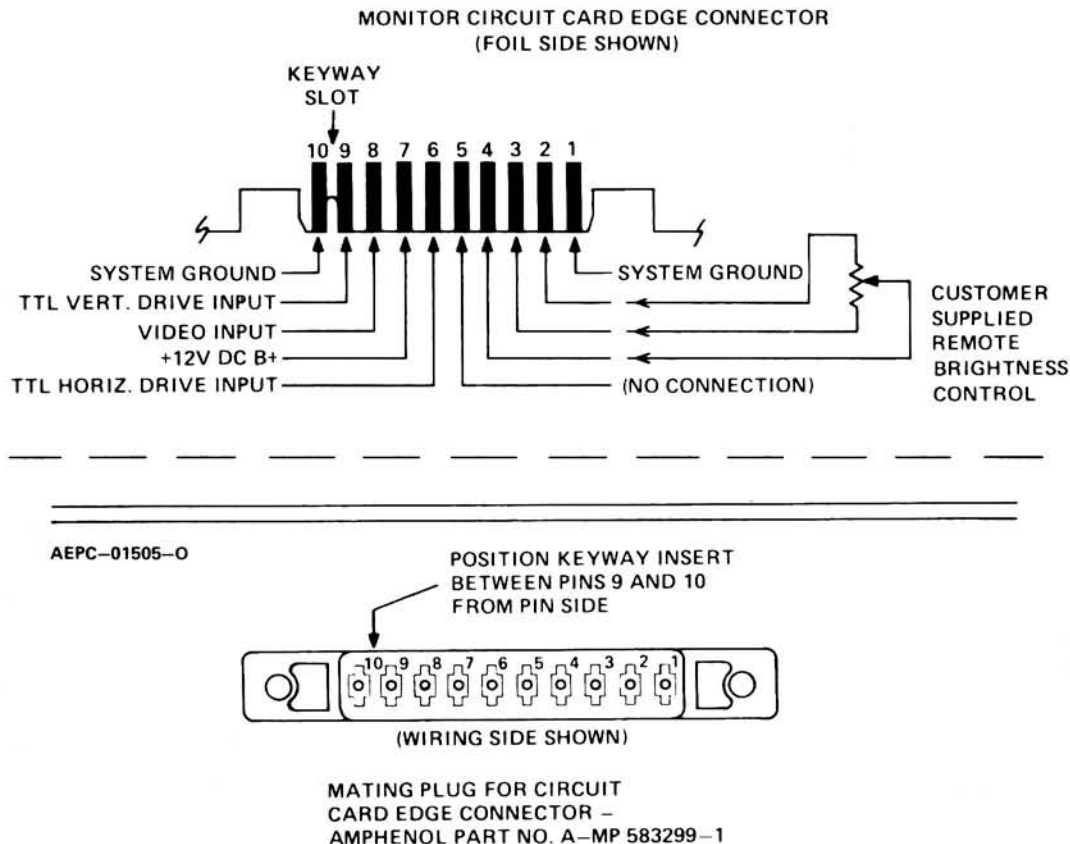

Figure 2. Model MD3970-74 Series Kit Version, Circuit Card Edge Connector