

# CHAPTER 2 DISASSEMBLY AND REASSEMBLY

## CONTENTS

<b>2.1</b>	<b>Precautions for disassembly and reassembly</b> .....	2-1
<b>2.2</b>	<b>Disassembly and reassembly of the main unit</b> .....	2-2
2.2.1	Optional cover and upper case .....	2-2
2.2.2	Q10GMS board .....	2-4
2.2.3	Q10SYM board .....	2-5
2.2.4	Q10PS board (Power supply unit) .....	2-6
2.2.5	FDD (SD-321) unit .....	2-7
2.2.6	Power lamp .....	2-8
<b>2.3</b>	<b>Disassembly and reassembly of CRT (green monitor unit)</b> .....	2-9
2.3.1	Cover .....	2-9
2.3.2	CRT .....	2-10
2.3.3	Board (CRT drive unit) .....	2-11
<b>2.4</b>	<b>Disassembly and reassembly of the keyboard unit</b> .....	2-12
2.4.1	Cover .....	2-12
2.4.2	Replacement of key switches and LED lamps .....	2-13
<b>2.5</b>	<b>SD-321 mechanism</b> .....	2-14
2.5.1	Main board set .....	2-14
2.5.2	Voice coil motor unit (VCM unit) .....	2-16
2.5.3	Sub-frame, collet set, collet lever and pad arm .....	2-18
2.5.4	Front panel .....	2-20
2.5.5	Disk guide (L) unit, write protector set and eject transmission level .....	2-21
2.5.6	Disk drive motor and endless belt .....	2-24
2.5.7	Disk guide (R), idler set and disk drive pulley set .....	2-26
2.5.8	Index detector A set .....	2-28
2.5.9	Index detector B set .....	2-30
2.5.10	Eject lock lever set .....	2-32

## 2.1 Precautions for disassembly and reassembly

Before disassembling or reassembling the QX-10, pay attention to the following.

- 1) Make sure the power switch is turned off.  
Disconnect the AC cable from the AC inlet.
- 2) Disconnect the cables of the keyboard, CRT unit, etc. connected to the QX-10.
- 3) Power is charged in the electrolytic condenser in the power supply unit for a few minutes after the power switch is turned off. So take care to avoid electric shock.
- 4) Take special care to keep the CRT unit away from cathode rays or the yoke coil.  
If the anode cap is removed, it must be properly discharged with a resistor of about 10 M $\Omega$  interposed between the cap and GND.
- 5) When a substrate using ICs such as a circuit board is handled, be sure to touch a grounded device with your hands to discharge static electricity prior to handling.
- 6) Be sure to use the specified screws. (See Table 2-1)
- 7) Do not touch the contact surfaces of connectors with bare hands.
- 8) When the Q10 SYM substrate is removed or transported, disconnect the battery connector CN12.

Abbreviations for screws and small parts







Abbreviation	Name	Rough Sketch
CS	Cup screw	
CP	Cross-recessed pan head machine screw	
CB	Cross-recessed head blind tapping screw	
CPO	Cross-recessed head C.P.screw (with outside toothed lock washer)	
CTB	Cross-recessed head blind tapping screw	
CTC	Cross-recessed head cup tapping screw	
CTBR	Cross-recessed head Brajier head tapping screw	
CO	Cross-recessed head oval counter sunk screw	
HH	Hexagon socket half-point set screw	
PW	Plane washer	
SW	Spring washer	
OW	Outside toothed lock washer	
CW	Conical toothed lock washer	
HN	Hexagon nut	

Table 2-1

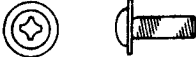
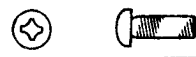
## 2.2 Disassembly and reassembly of the main unit

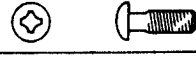
### 2.2.1 Optional cover and upper case

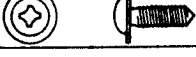
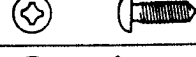
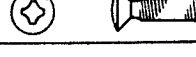
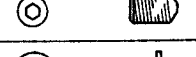
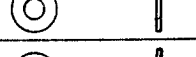
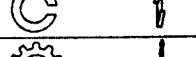
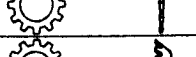
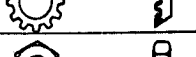
Disassembly procedure	Notes on disassembly
<p>1. Remove two screws of the optional cover shown in Fig. 2-1.</p> <p>CB: M4 × 12 × 4</p>	 <p>Fig. 2-1</p>
<p>2. Remove the connector cap A between the option cover and lower case.</p>	<p>● To replace connector cap A, first replace the optional cover and then insert the lower part of connector cap A into the groove of the lower case and push the upper part.</p>
<p>3. Remove two screw hole caps located in the right end of the upper case top with a (-) screwdriver.</p>	 <p>Fig 2-2</p>
<p>4. Remove the the four set screws of the upper case shown in Fig. 2-3.</p> <p>CS: M4 × 12 × 4</p>	 <p>Fig 2-3</p>
<p>5. Remove the two connectors shown in Fig. 2-4.(CN6 and CN7 on the Q10 SYM substrate)</p>	 <p>Fig. 2-4</p>

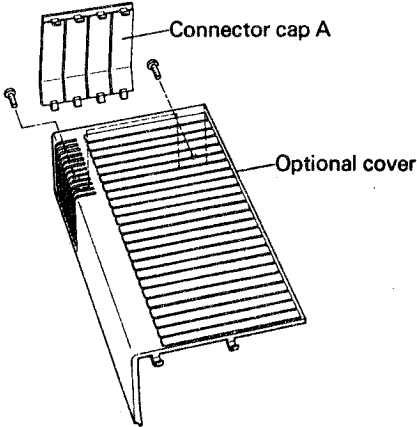
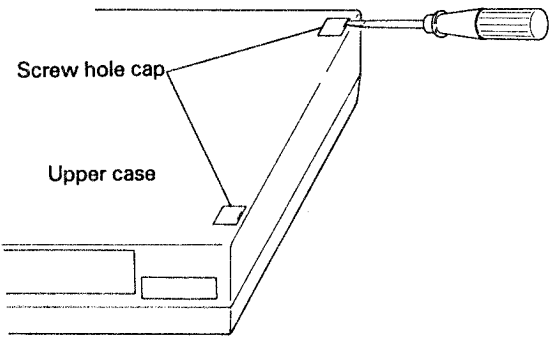
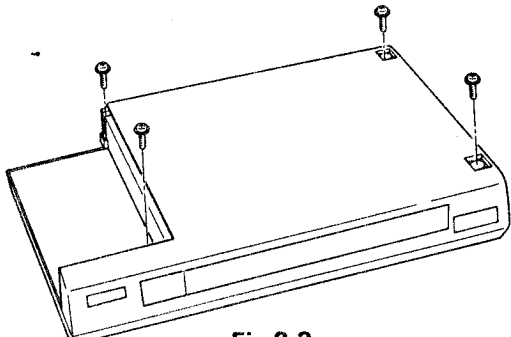
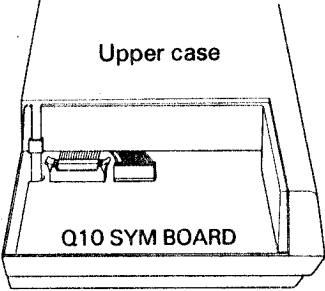
### Disassembly procedure

6. Note: Upper and lower cases are connected via the grounding wire.  
Lift the upper case by hand and remove it so that the rear part come to the front, and put it in front of the lower case.

7. Remove the screw on the right side of the speaker of Q10 SYM board, and disconnect the grounding wire.

CTC: M3 × 12 × 1

- Carry out above procedure in reverse for reassembly.

### Notes on disassembly

- The CN6 us 1 Upper case lock type, and should be removed by opening left and right levers.
- When replacing, make sure the cables of CN7 and CN7 are not trapped by the case or Q10 GMS board.

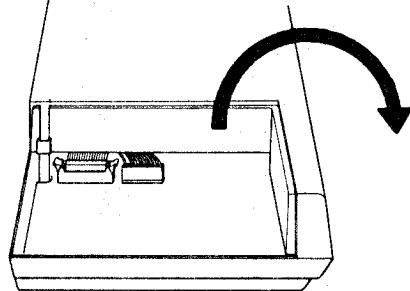

Fig. 2-5

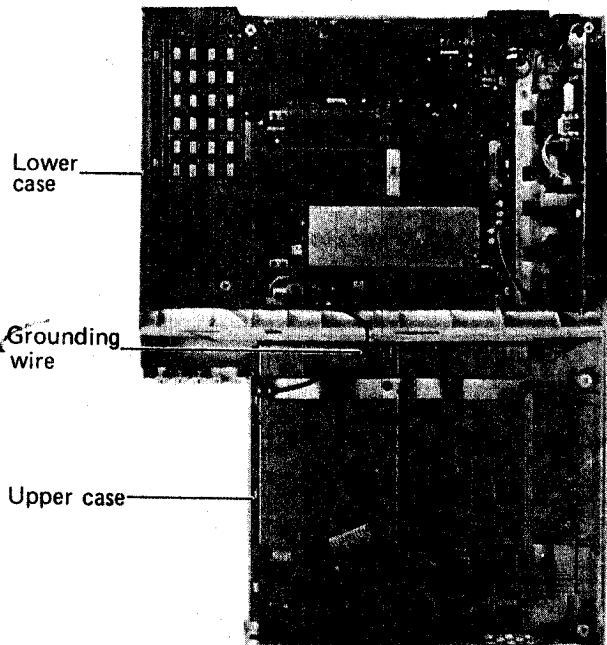

Fig. 2-6

- When replacing, make sure the cables of CN7 and CN7 are not trapped by the case or Q10 GMS board.

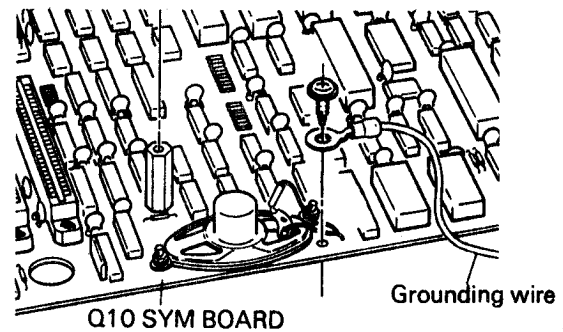

Fig. 2-7

- The tightening torque is 5 kg·cm.

## 2.2.2 Q10 GMS board

Disassembly procedure	Notes on disassembly
<p>1. Remove the upper case referring to 2.2.1.</p> <p>2. Remove screws No. 1 ~ 4 shown in drawing on the right.</p> <p>CTB: M3 × 10 × 1 CPO: M3 × 8 × 3</p> <p>3. Hold the Q10 GMS board by both hand and lift it straight up. Then the connector on the right of the screw 1 shown in Fig. 2-8 comes off.</p> <p>4. Remove grounding plate C and shielding plate attached to the Q10 GMS board.</p> <p>CPO: M3 × 8 × 3 OW: M3 × 3 HN: M3 × 3</p> <p style="text-align: center;">Fig. 2-9</p>	<p style="text-align: center;">Fig. 2-8</p> <ul style="list-style-type: none"> <li>● Before handling the board, be sure to discharge the static electricity from your body.</li> <li>● To replace the board, set connectors CN9 and CN10 correctly and securely in the Q10 SYM board.</li> <li>● When replacing the board, pay attention to the direction of grounding plate C.</li> </ul> <p>Note: When a defective Q10 GMS board is replaced, grounding plate C and shielding plate are not included in spare parts.</p> <ul style="list-style-type: none"> <li>● The tightening torque of screw 1 shown in Fig. 2-8 is 5 kg·cm.</li> </ul>
<ul style="list-style-type: none"> <li>● Carry out above procedure in reverse for reassembly.</li> </ul>	

### 2.2.3 Q10 SYM board

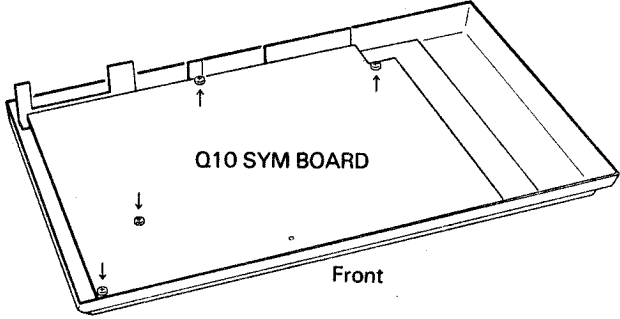
Disassembly procedure	Notes on disassembly
<p>1. Remove the upper case and Q10 GMS board referring to 2.2.1 and 2.2.2.</p> <p>2. Remove the four screws indicated by arrow marks in the drawing on the right.</p> <p>CTB: M3 × 10 × 4</p> <p>3. Remove the connector on the Q10 SYM board.</p> <p>CN8 – Power supply CN13 – FAN CN12 – Battery</p> <p>4. Remove the board by opening the claws provided on the left and right sides of the board.</p> <p>5. Take off the board.</p> <ul style="list-style-type: none"><li>● Carry out above procedure in reverse for reassembly.</li></ul>	 <p>Fig. 2-10</p> <ul style="list-style-type: none"><li>● The tightening torque of the screws is 5 kg·m.</li></ul> <p>Note: The connector for connection between CN12 and battery must also be removed when the board itself is transported to prevent shorting of the battery</p> <ul style="list-style-type: none"><li>● Before holding the board, be sure to discharge the static electricity from your body.</li><li>● Take off the board lifting the front side first.</li><li>● To replace it, insert the rear side first.</li></ul>

## 2.2.4 Q10PS board (Power supply unit)

Disassembly procedure	Notes on disassembly
<p>1. Remove the upper case according to 2.2.1.</p> <p>2. Disconnect the AC input connector CN1 and the connector connected to CN8 of the Q10 SYM board.</p> <p>3. Remove the four screws shown in the drawing on the right.            CS: M4 × 8 × 4            OW: M4 × 4</p> <p>4. Remove the grounding plate.</p> <p>5. Lift the power supply unit and take it off.</p> <p>● Carry out above procedure in reverse for reassembly.</p>	<div data-bbox="843 479 1354 831" data-label="Image"> </div> <p data-bbox="1016 857 1114 887"><b>Fig. 2-11</b></p> <ul data-bbox="785 920 1373 1077" style="list-style-type: none"> <li>● To replace the grounding plate, pay attention to the direction (with the tooth tip facing up and left).</li> <li>● In the part A shown in Fig. 2-11, attach screws, grounding wire press terminal and toothed washer in that order.</li> </ul> <div data-bbox="788 1137 1244 1279" data-label="Image"> </div> <p data-bbox="1009 1312 1114 1341"><b>Fig. 2-12</b></p> <ul data-bbox="785 1375 1373 1464" style="list-style-type: none"> <li>● When a defective power supply unit is replaced, insulating paper A shown in Fig. 2-11 is not included in spare parts.</li> </ul>

## 2.2.5 FDD (SD-321) unit

Disassembly procedure	Notes on disassembly						
<p>1. Remove the upper case according to 2.2.1.</p> <p>2. Remove screws A,B and C or D,E and F (FDD-A/B side) shown in Fig. 2-13</p> <p>CPO: M4 x 8 x 5 (Screws B ~ F in Fig. 2-13)</p> <p>CS: M4 x 8 x 1</p> <p>OW: M4 x 1 (Screw A in Fig. 2-13)</p> <p>3. Remove the two connectors of FDD.</p> <p>4. Pull out the FDD in the direction of the arrow shown in Fig. 2-13 (case front side).</p>	<div data-bbox="884 293 1398 680" data-label="Diagram"> </div> <p style="text-align: center;">Fig. 2-13</p> <ul style="list-style-type: none"> <li>● The lead of the grounding wire of screw A should be attached in the direction shown in Fig.2-13</li> <li>● Grounding plate B is mounted like a wave.</li> <li>● When a defective FDD is replaced, make secure setting of the following DIP switch and mounting of the terminator.</li> </ul>						
<ul style="list-style-type: none"> <li>● Carry out above procedure in reverse for reassembly.</li> </ul>	<table border="1" style="width: 100%; text-align: center;"> <thead> <tr> <th data-bbox="824 1214 1141 1258">FDD-A</th> <th data-bbox="1141 1214 1464 1258">FDD-B</th> </tr> </thead> <tbody> <tr> <td data-bbox="824 1258 1141 1496"> <p>Only 1 ON</p> </td> <td data-bbox="1141 1258 1464 1496"> <p>Only 2 ON</p> </td> </tr> <tr> <td data-bbox="824 1496 1141 1563"> <p>Without terminator</p> </td> <td data-bbox="1141 1496 1464 1563"> <p>With terminator</p> </td> </tr> </tbody> </table> <p style="text-align: center;">Fig. 2-14</p>	FDD-A	FDD-B	<p>Only 1 ON</p>	<p>Only 2 ON</p>	<p>Without terminator</p>	<p>With terminator</p>
FDD-A	FDD-B						
<p>Only 1 ON</p>	<p>Only 2 ON</p>						
<p>Without terminator</p>	<p>With terminator</p>						

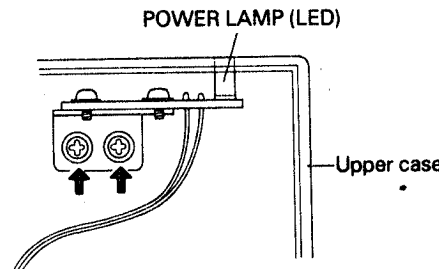
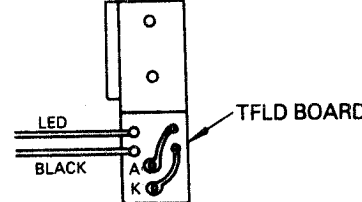
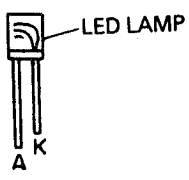

## 2.2.6 Power lamp

Disassembly procedure	Notes on disassembly
<ul style="list-style-type: none"><li>• Disassembly is necessary when the power lamp is found to be defective.</li></ul> <ol style="list-style-type: none"><li>1. Remove the upper case according to 2.2.1.</li> <li>2. Remove the two screws indicated by arrows in Fig. 2-15.  CTC: M3 × 8 × 2</li> <li>3. Remove the solder of A and K shown in Fig. 2-16, and remove the LED lamp.</li> <li>4. The pole with the longer lead wire as shown in Fig. 2-17 is the anode of the LED lamp. Insert the lamp into the TFLD board shown in Fig. 2-16 in the correct direction, ensuring close contact.</li> <li>5. Solder the lamp</li>  <li>6. Tighten the two screws mentioned in step 2.</li></ol>	 <p>POWER LAMP (LED)</p> <p>Upper case</p> <p>Fig. 2-15</p>  <p>LED</p> <p>BLACK</p> <p>A</p> <p>K</p> <p>TFLD BOARD</p> <p>Fig. 2-16</p>  <p>LED LAMP</p> <p>A</p> <p>K</p> <p>Fig. 2-17</p>

## 2.3 Disassembly and reassembly of CRT (green monitor unit)

### 2.3.1 Cover

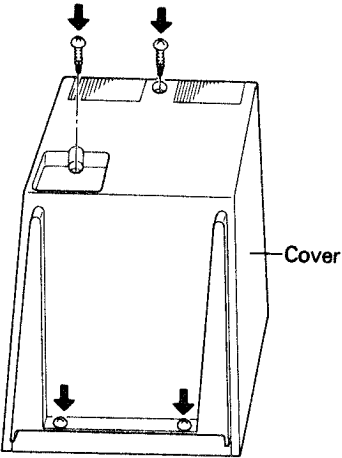
Disassembly procedure	Notes on disassembly
<p>1. Set the unit with the CRT screen down.</p> <p>2. Remove the four screws indicated by arrows in Fig. 2-18.</p> <p>CTBR: M4 × 16 × 4</p> <p>3. Lift the cover.</p> <p>● Carry out above procedure in reverse for reassembly.</p>	<p>● There are many high voltage parts in the green monitor. Be careful not to touch them.</p>  <p>Fig. 2-18</p>

## 2.3.2 CRT

Disassembly procedure	Notes on disassembly
<p>1. Discharge through a resistor of about 25M<math>\Omega</math> inserted between the anode cap terminal and GND (ground frame).</p>  <p>2. Disconnect the cable connectors (2) coming from the DY (deflection yoke) shown in Fig. 2-19 from the board.</p> <p>3. Disconnect the grounding wire connector coming from the middle of the wire which makes connection between the CRT fixing screws 2 and 3, from the board.</p> <p>4. Remove the socket shown in Fig. 2.19.</p> <p>5. Remove four screws 1 ~ 4 shown in fig. 2-19.</p> <p>CTC: M4 x 116 x 4  OW: M4 x 2  PW: M4 x 0.8 x 16 x 2</p> <p>● Carry out above procedure in reverse for reassembly.</p>	<p>● High voltage is applied to the CRT. Keep this in mind and take care.</p> <p>● Screws 3 and 4 should be used as shown below.</p> 

Fig. 2-19

Fig. 2-20

### 2.3.3 Board (CRT drive unit)

Disassembly procedure	Notes on disassembly
<p>1. Carry out steps 1 ~ 4 of 2.3.2.</p> <p>2. Remove screws 1 ~ 4 shown in Fig. 2-21.</p>	<p>● High voltage is applied to the board. Keep in mind and take care.</p>  <p>Fig. 2-21</p>

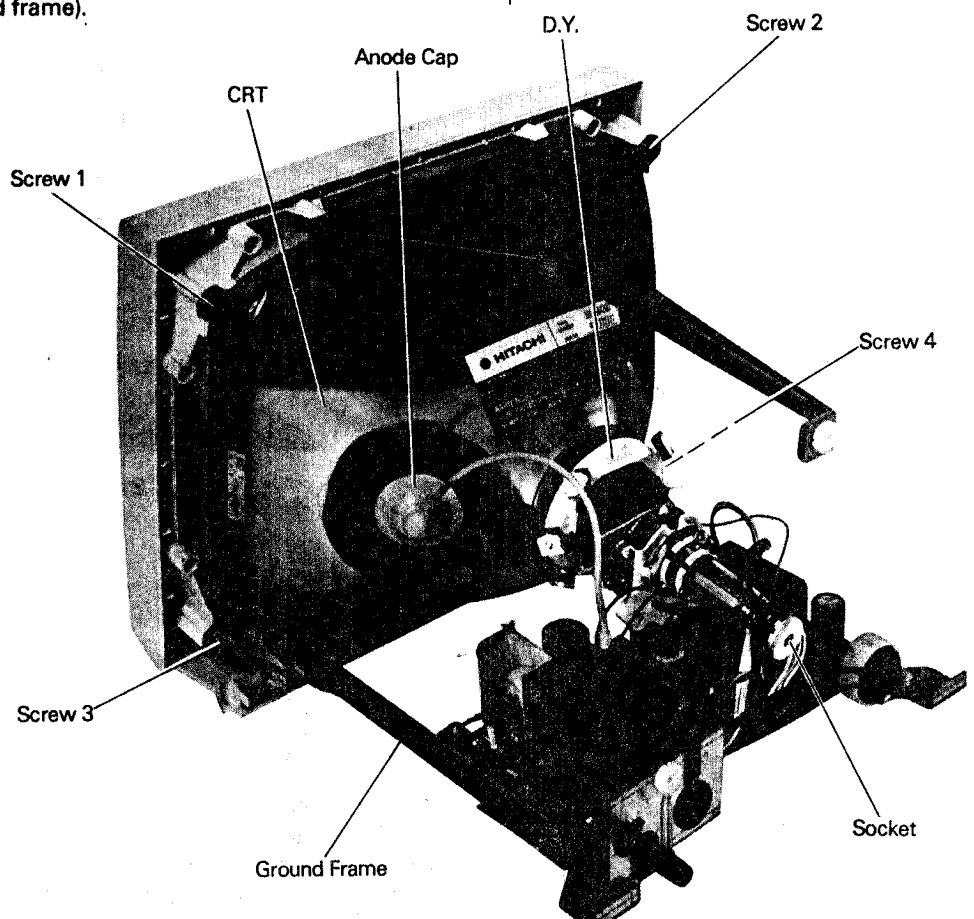
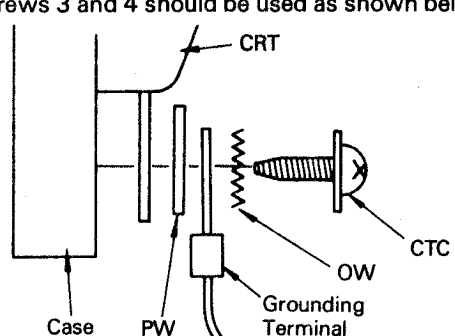
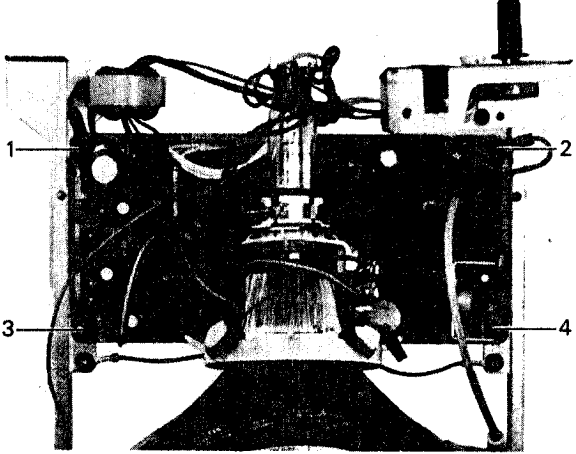
## 2.4 Disassembly and reassembly of the keyboard unit

### 2.4.1 Cover

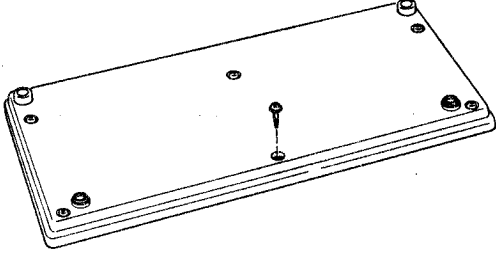
Disassembly procedure	Notes on disassembly
<p>1. Set the unit with the key top down.</p> <p>2. Remove the six screws shown in Fig. 2-21</p> <p>CTC M4 x 12 x 4</p> <p>3. Remove upper and lower cases, and take off the keyboard unit.</p>	 <p>Fig. 2-22</p>

## 2.4.2 Replacement of key switches and LED lamps

Disassembly procedure	Notes on disassembly
<p>• Replacement is necessary when the key switch malfunctions. Check continuity using a circuit tester.</p> <p>1. Remove all the the screws (cup and tapping screws) on the soldered surface of the keyboard unit.</p> <p>2. Lift the unit straight up holding part { } shown in Fig. 2-23 with the key top up.</p>	
	
<p>3. Key switch Desolder the defective key switch and replace it.</p> <p>LED lamp Desolder the defective LED and replace it.</p> <p>● Carry out above procedure in reverse for reassembly.</p>	

Fig. 2-23

## 2.5 SD-321 mechanism

### 2.5.1 Main board set

Disassembly procedure	Notes on disassembly
<p>1) Remove the main board fixing screws. (See Fig. 2-24)</p> <p>A) Front panel CTC M2.5 × 6 B) Disk guide R CTC M2.5 × 6 C) Disk drive motor CS M2.5 × 4 D) Radiator plate CS M2.5 × 25</p> <p>2) Lift the main board so that it is almost parallel to the main frame.</p> <p>3) Disconnect the connector of the head lead wire. (See Fig. 2-25.)</p>	
 <p>Fig. 2-24</p>	 <p>Fig. 2-25</p>

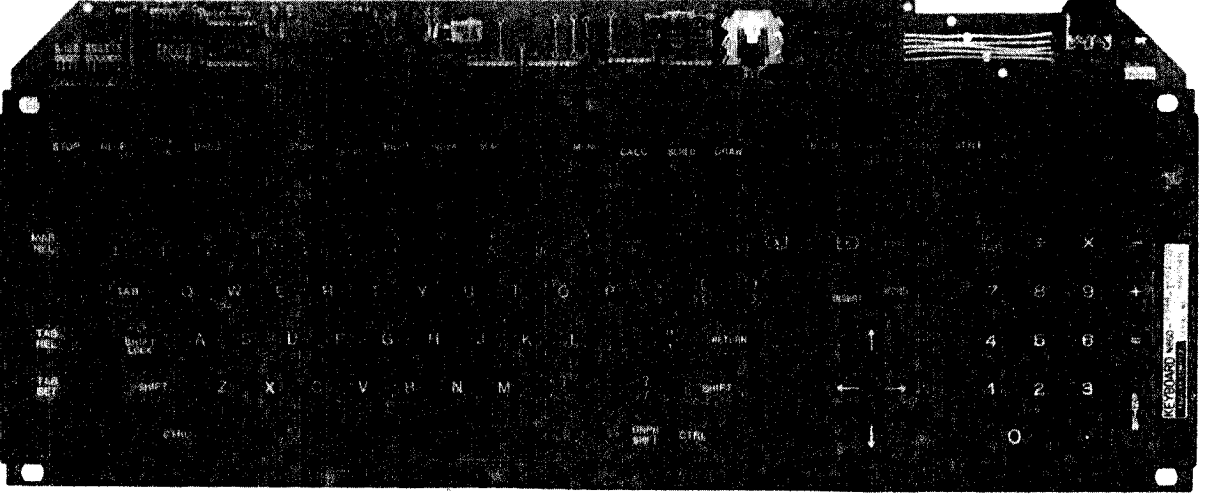
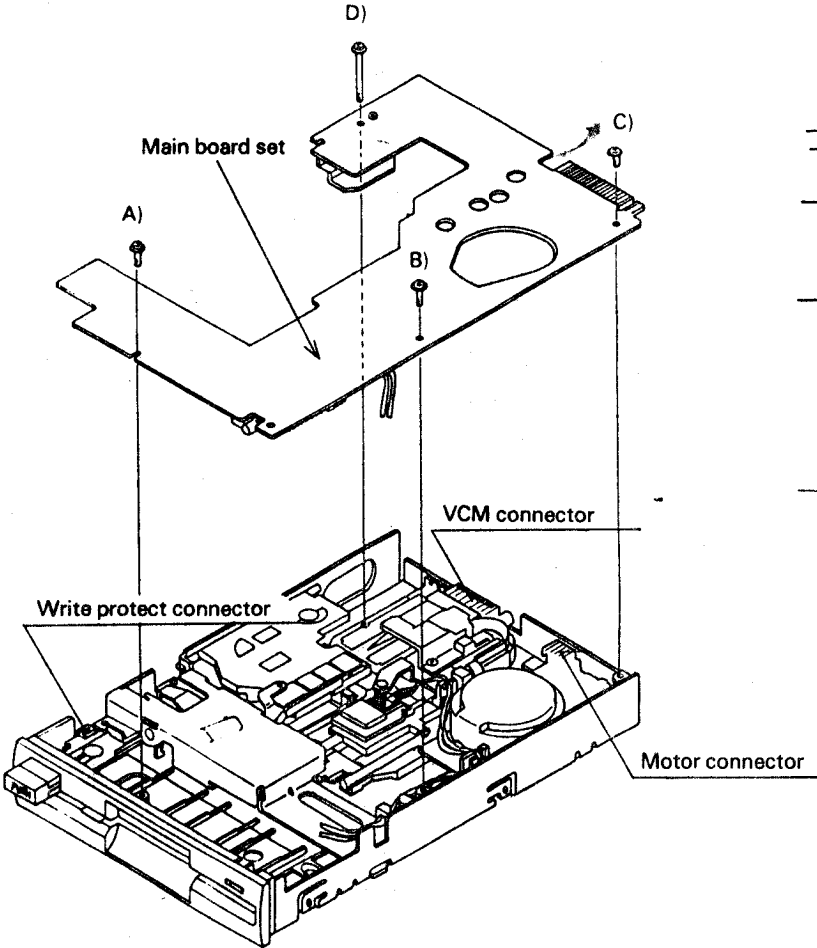
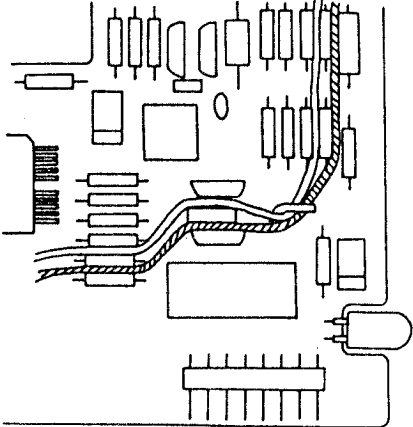
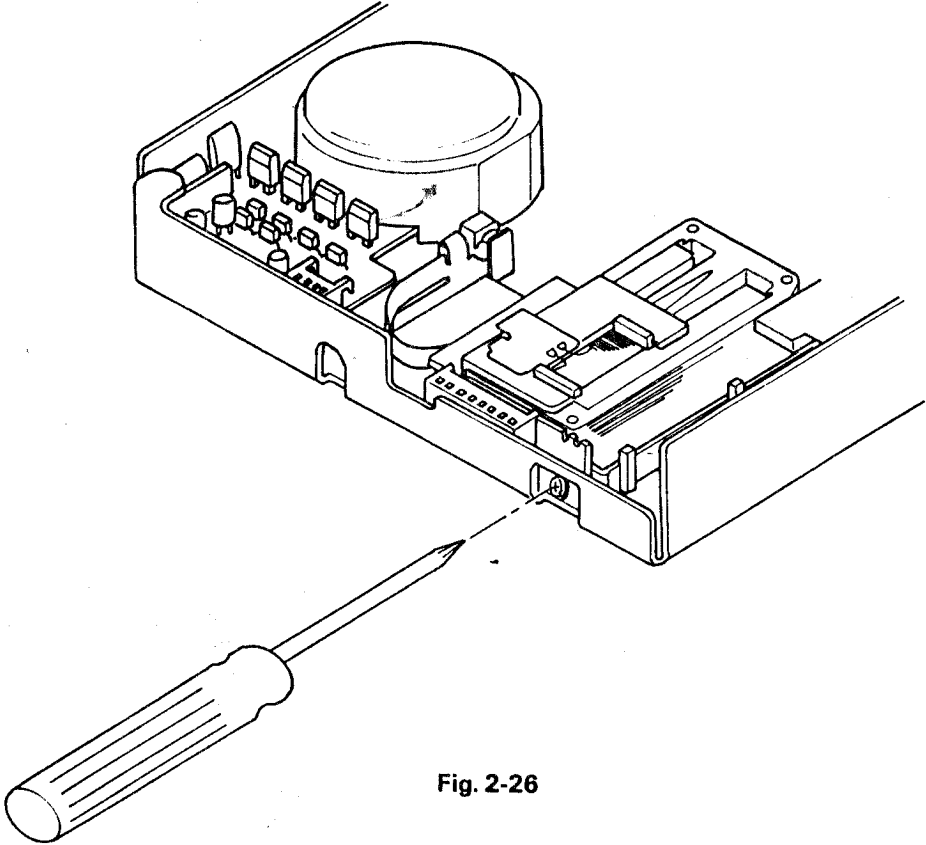
Disassembly procedure	Notes on disassembly
<p>1) Check the head lead wire follows the specified route. (Fig. 2-25)</p> <p>2) Check each connector is in the correct position, and set the main board set.</p> <p>3) Tighten the main board set fixing screws. Tightening torque: 4.0 kg-m for A) ~ D)</p>	<p>Note 1. Take care not to damage the terminal when the connector is connected or disconnected.</p> <p>Note 2. If the VCM connector does not coincide with the main board connector, loosen the VCM flexible lead plate fixing screw a little, adjust the connectors and then re-tighten the screw. (Fig. 2-26)</p> <p>Note 3. Before tightening the main board fixing screws, make sure that the head lead wire is not trapped by the front panel.</p>
	
<p><b>Fig. 2-26</b></p>	

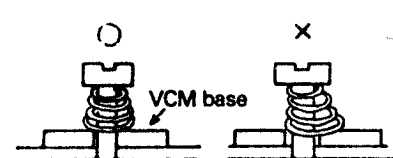
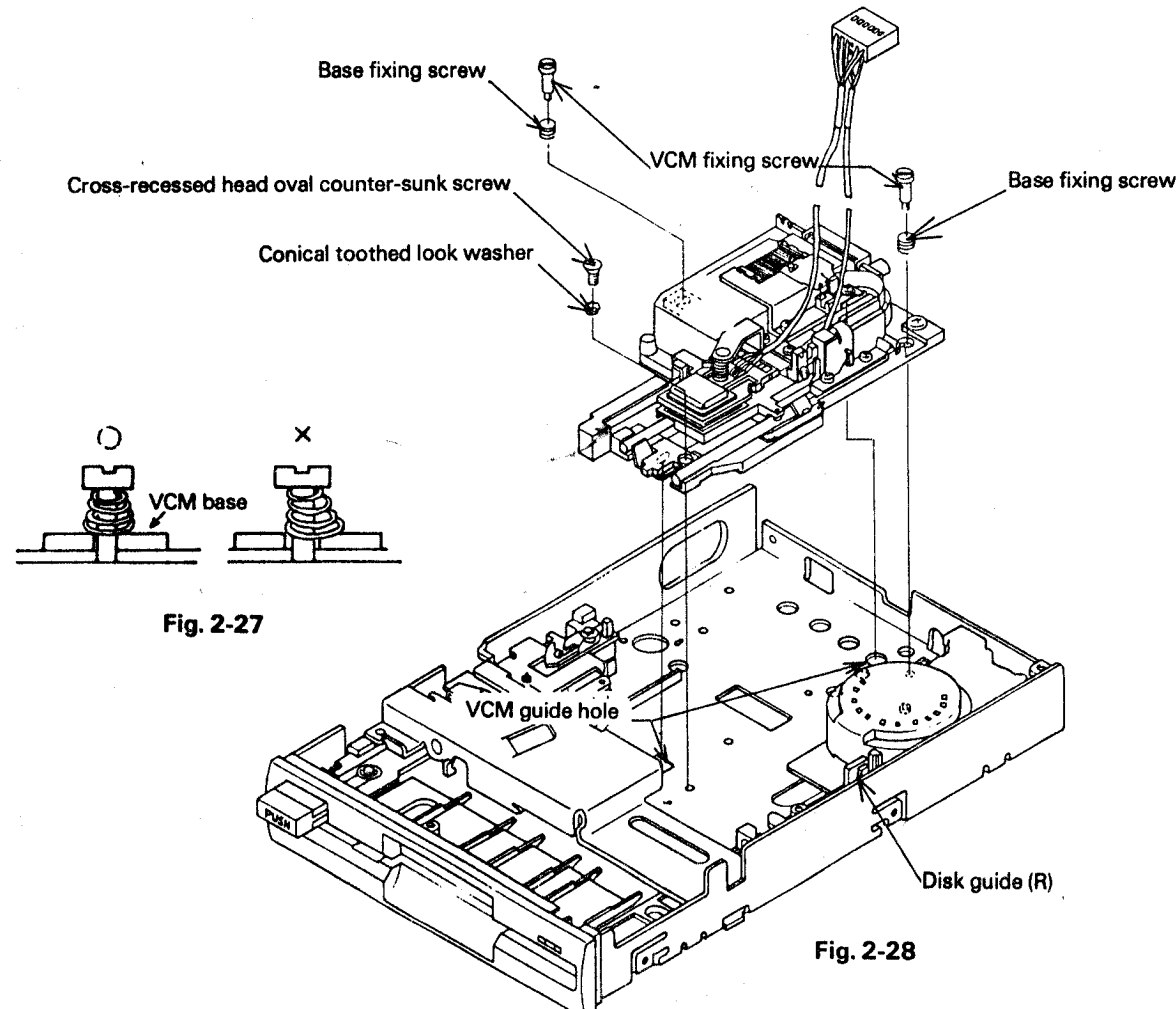

## 2.5.2 Voice coil motor unit (VCM unit)

Disassembly procedure	Notes on disassembly
<p>1) Take off the main board set. (See 2.5.1.)</p> <p>2) Remove the clamp of the head lead wire.</p> <p>3) Remove the VCM fixing screws and cross-recessed head oval counter-sunk screw, and take off the VCM unit from the main frame. (Fig. 2-28)</p>	<ul style="list-style-type: none"> <li>● Insert insulating paper between upper and lower heads.</li> </ul>
 <p>Fig. 2-27</p>	 <p>Fig. 2-28</p>

Disassembly procedure	Notes on disassembly
<p>1) Set the VCM unit so that it fits in the guide hole of the main frame.</p> <p>2) Set the base fixing screw, VCM fixing screws, conical toothed lock washer and cross-recessed head oval counter-sunk screw. Fix the VCM unit while pushing it toward the disk guide (R) and rear side. (Screw tightening torque: 5.0 kg·cm)</p> <p>3) Connect the head lead wire to the disk guide (R) and the specified positions of the main board set. (Figs. 2-25 and 2-26)</p> <p>4) Mount the main board set. (Refer to 2.5.1) (Fig. 2-28)</p> <p>* Method of clamping the head lead wire to the disk guide (R) Fig. 2-29</p>	<p>● The base fixing spring should not incline beyond the VCM base. (Fig. 2-27)</p>
<p>1. Set the head lead wire to the head lead wire clamping position of the disk guide (R). Set the head lead wire as follows:</p> <p>A) Move the VCM drive coil to track 00.</p> <p>B) Set the upper head lead wire so that it touches the front end of the clamp position wall of the disk guide (R)</p> <p>C) Hold the part making contact between the wire and wall with tweezers, move it to the right of the clamping position and set it in the clamping position as it is.</p> <p>D) Hook the lower head lead wire on the bent and raised part of the slide axis holder B and bring it to the disk guide (R) clamping position.</p> <p>E) Set the wire in the clamping position with tweezers so that the clearance between the wire and the clamping position is about 2 mm.</p> <p>Note 1. In the lower head holder and disk guide (R) clamping position, upper and lower head lead wires are upside down.</p> <p>Note 2. The upper head lead wire crossed the lower head lead wire from the front panel side.</p> <p>2. Check sliding of the head lead wire.</p> <p>1) The lead wire should not be over tightened in track 00.</p> <p>2) The lead wire should not come out of the slide axis holder B in track 39.</p> <p>3. Connect the head lead wire to the disk guide (R). Route the head lead wire through the lead wire guide provided on the disk guide (R).</p>	 <p>The diagrams in Figure 2-29 illustrate the process of clamping the head lead wire. The top diagram shows the disk guide (R) with the head lead wire being positioned. The middle diagram shows the slide axis holder B being moved to clamp the wire, with a 2mm clearance indicated. The bottom diagram shows the final clamped position of the head lead wire.</p>

Fig. 2-29

### 2.5.3 Sub-frame, collet set, collet lever and pad arm

Disassembly procedure	Notes on disassembly
<p>1) Remove the main board set. (Refer to 2.5.1)</p> <p>2) Remove the slide lever spring.</p> <p>3) Remove the sub-frame unit fixing screws. (Fig. 2-30) CS M2.5 × 19 × 3</p> <p>4) Remove the sub-frame unit from the main unit.</p> <p>5) Remove the pad arm fixing screw from the sub-frame unit, and pull the pad arm to the front (in the direction of the arrow shown in Fig. 2-30). SF thin M2 × 4 (P 0.25) × 1</p> <p>6) Push the collet lever down until the collet set is disengaged in arrow A direction from the collet guide shaft. Move the collet set gently in arrow B direction shown in Fig. 2-31 and remove it from the collet lever.</p> <p>7) Remove the E stopper ring of the collet lever shaft and take off the shaft. RE ETWJ-2.3 × 1</p>	<ul style="list-style-type: none"> <li>● Since the upper head arm is placed on the collet bar arm, care should be taken not to drop the upper head onto the lower head.</li> </ul>
 <p style="text-align: center;">Fig. 2-30</p>	 <p style="text-align: center;">Fig. 2-31</p>

Disassembly procedure	Notes on disassembly
<ol style="list-style-type: none"> <li>1) Set the collet lever and collet lever spring in the sub-frame, and fix the unit with the E stopper ring through the collet lever shaft.</li> <li>2) Rotate the collet lever and set the collet in the collet lever groove.</li> <li>3) Adjust the collet center hole to the sub-frame guide shaft, and set the collet in the sub-frame.</li> <li>4) Check the collet rotation and collet lever operation.</li> <li>5) Make sure the disk guide sleeves have been set in the disk guide (L) and (R) units.</li> <li>6) Set the sub-frame unit in the main unit, Push the sub-frame unit backward toward the disk guide (L) unit, and fix it with the sub-frame unit fixing screws. (Screw tightening torque: 6.0 kg-cm)</li> <li>7) Hook the slide lever spring between the sub-frame and slide lever.</li> <li>8) Mount the main board set. (Refer to 2.4.1)</li> </ol>	<ul style="list-style-type: none"> <li>● Pay attention to the set of the collet lever spring (Fig. 2-32).</li> </ul>
 <p data-bbox="608 1653 1063 1684">(View of sub-frame unit seen from the bottom)</p> <p data-bbox="780 1720 890 1751"><b>Fig. 2-32</b></p>	

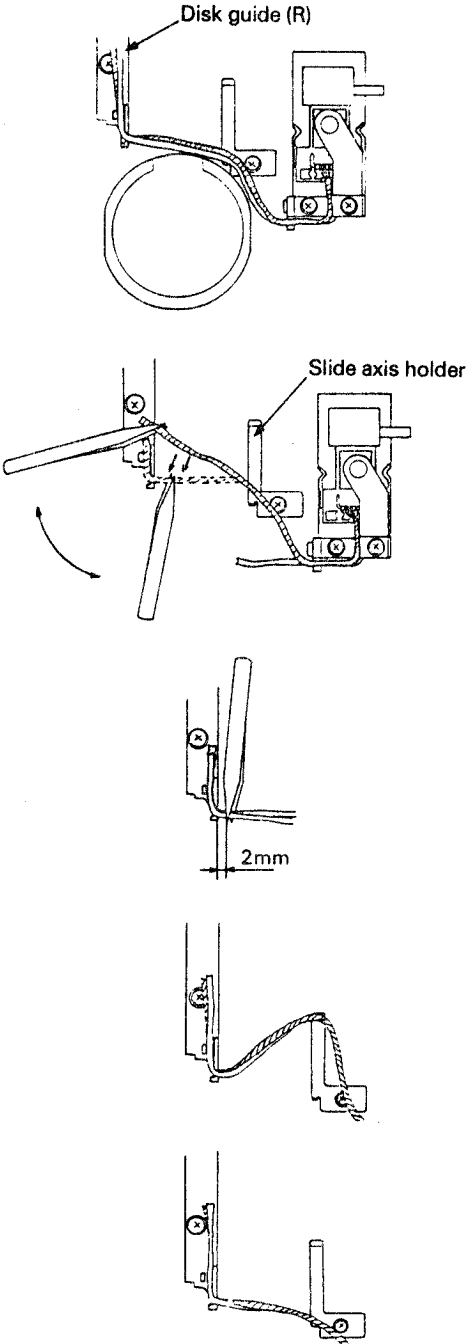
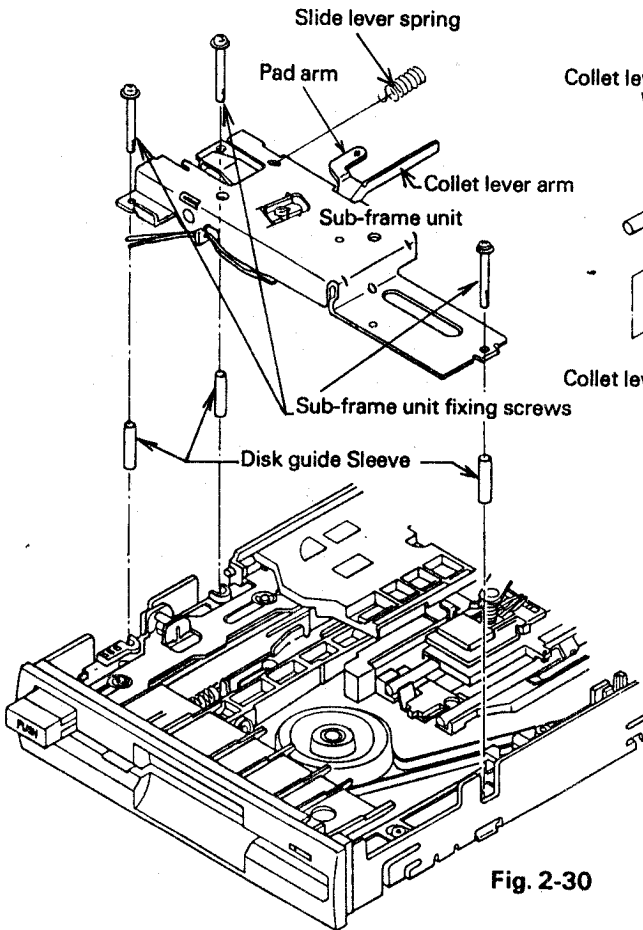
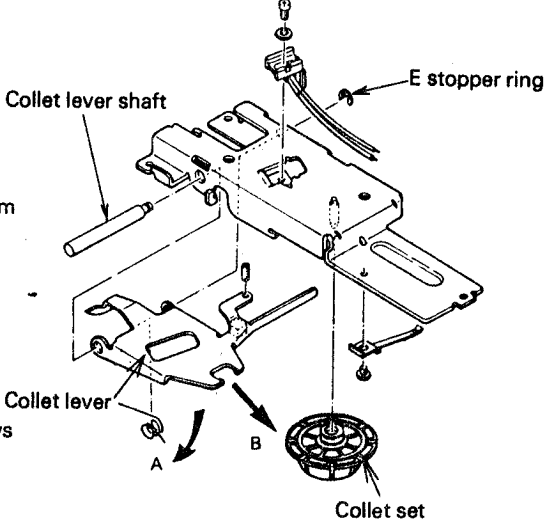
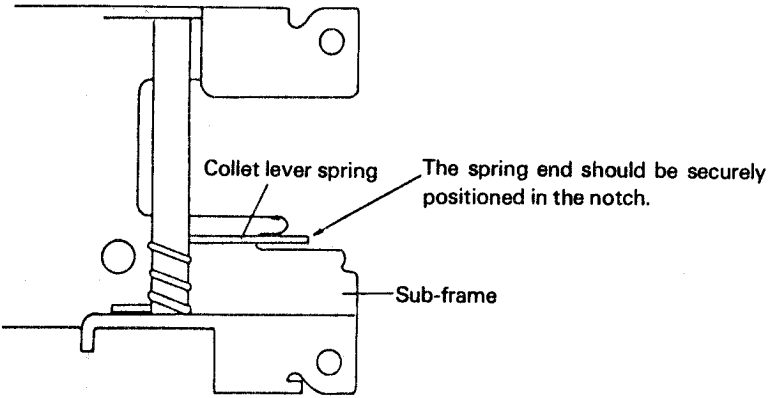
## 2.5.4 Front panel

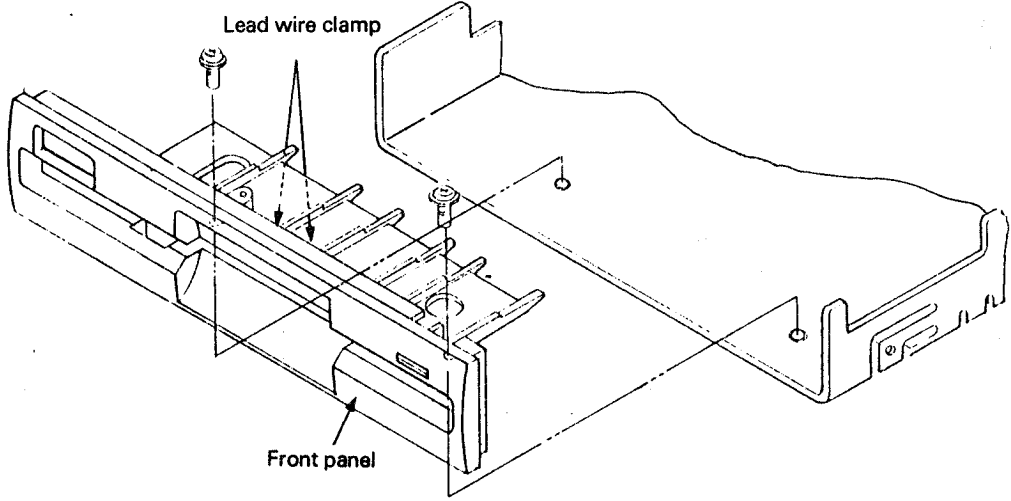
Disassembly procedure	Notes on disassembly
<p>1) Remove the main board set. (Refer to 2.5.1)</p> <p>2) Remove the front panel fixing screws, and take off the front panel by pulling it to the front. CS M2.5 × 4 × 2</p>	<ul style="list-style-type: none"> <li>● The front panel should be taken off taking care that it not caught by the lead wire of index detector B located under the front panel lead wire clamp.</li> </ul>
	
<p>Fig. 2-33</p>	
<p>1) Set the front panel, and hook the lead wire of index detector B on the front panel lead wire clamp.</p> <p>2) Fix the front panel to the main unit with the front panel fixing screws. (Screw tightening torque: 4.0 kg-cm)</p> <p>3) Mount the main board set. (Refer to 2.5.1)</p>	<ul style="list-style-type: none"> <li>● Insert the lead wire of the index detector B inside the claws (2) of the lead wire clamp. (Refer to Fig. 2-33)</li> </ul>

### 2.5.5 Disk guide (L) unit, write protect detector set and eject transmission level

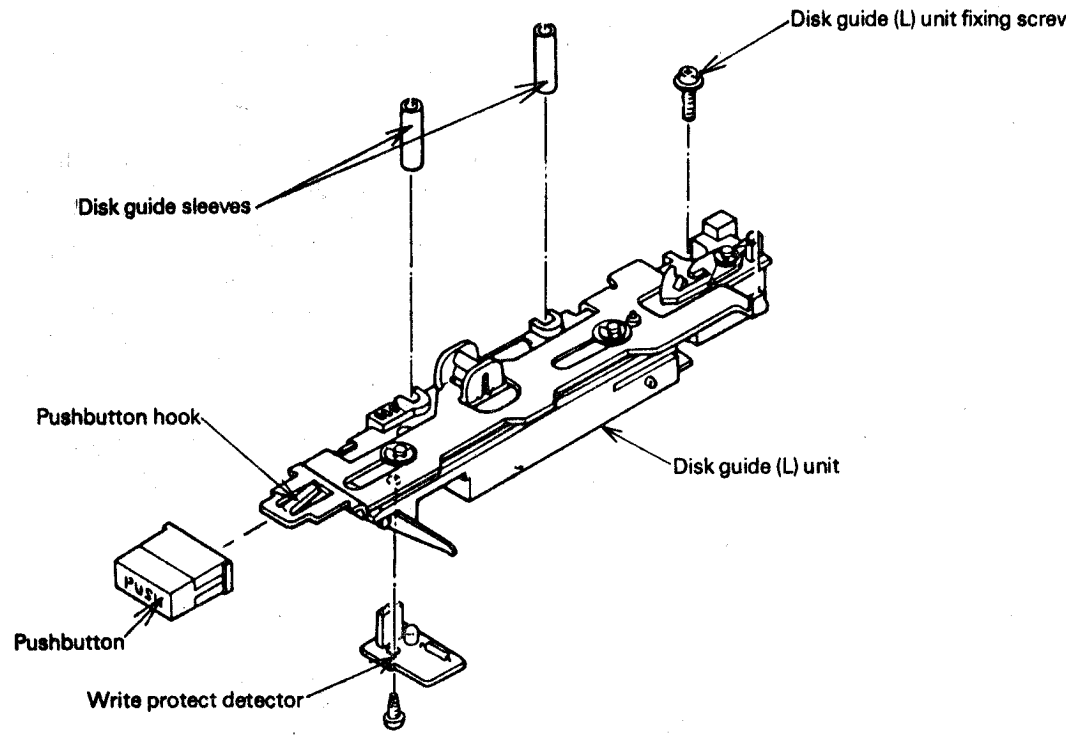
Disassembly procedure	Notes on disassembly
<p>1) Remove the main board set (Refer to 2.5.1)</p> <p>2) Remove the sub-frame unit. (Refer to 2.5.3)</p> <p>3) Remove the front panel fixing screws and take off the front panel by pulling it to the front. (Refer to 2.5.4) CS M2.5 x 4 x 2</p> <p>4) Remove the disk guide (L) unit fixing screw, and take off the disk guide (L) unit from the main unit.</p> <p>5) Remove the write protect detector fixing screw, and take off the write protect detector from the disk guide (L).</p> <p>6) Push the slide lever push buttonhook up, and remove the pushbutton.</p>	
 <p style="text-align: center;">Fig. 2-34</p>	

**Disassembly procedure**

**Notes on disassembly**

1) Lubricate the latch receiver of the disk guide (L).

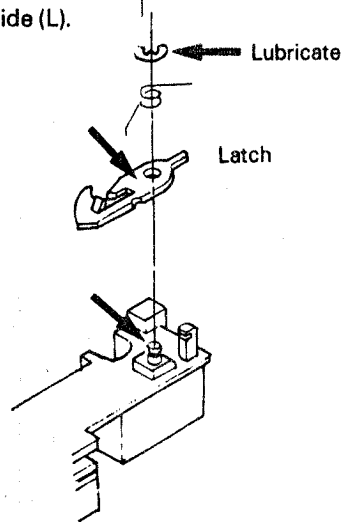

**Fig. 2-35**

2) Lubricate the part making contact between the safety lever and disk guide (L).

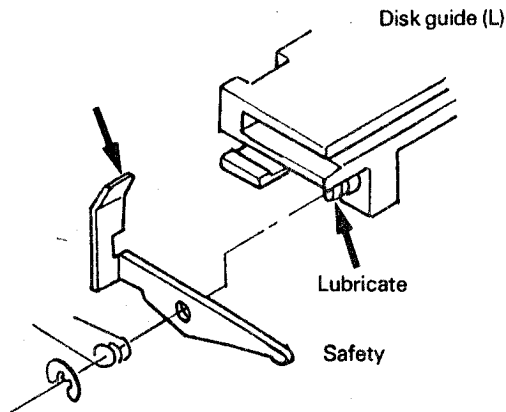

**Fig. 2-36**

3) Lubricate the eject transmission lever bearing of the disk guide (L).

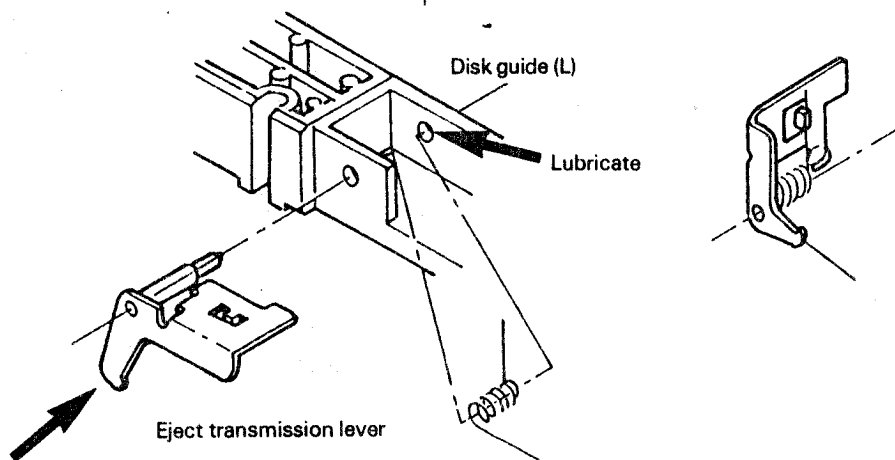

**Fig. 2-37**

4) Push the pushbutton into the disk guide (L).

**Disassembly procedure**

**Notes on disassembly**

- 5) Set the write protect detector board in the disk guide(L) and fix it with screw.  
(Screw tightening torque: 1.0 kg-cm)

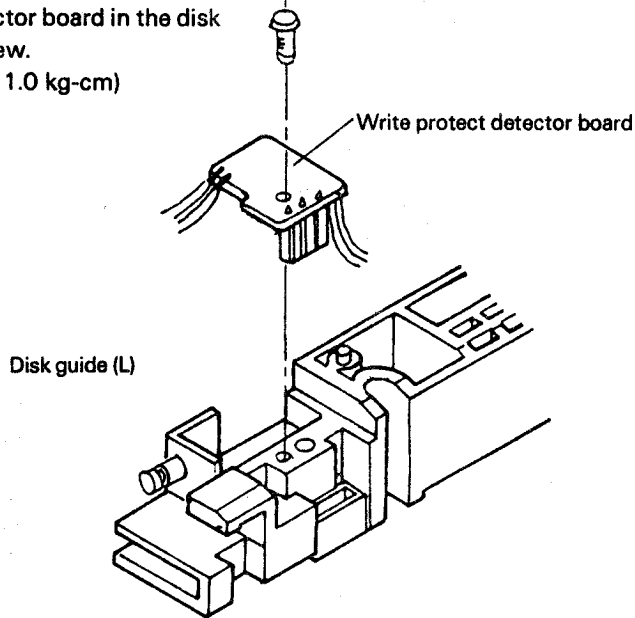

**Fig. 2-38**

- 6) Route the cable connecting the index detector B and write protect detector board pass under the eject lock lever.  
(Fig. 2-39)

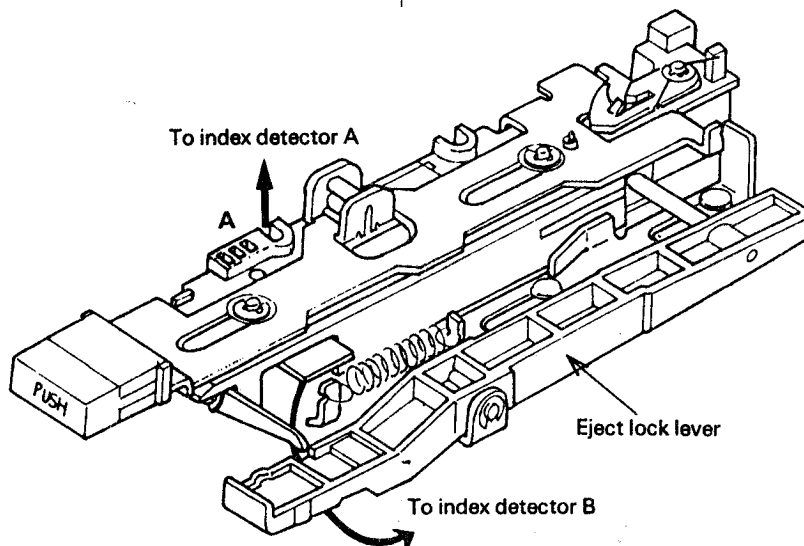

**Fig. 2-39**

- 7) Fix the disk guide (L) unit to the main unit with the disk guide (L) unit fixing screws.  
(See A of Fig. 2-39.)
- 8) Mount the front panel. (Refer to 2.5.4)
- 9) Mount the sub-frame unit. (Refer to 2.5.3)
- 10) Mount the main board set. (Refer to 2.5.1)

- Insert the cable connecting the write protect detector board and index detector A into the groove of the disk guide (L) unit.

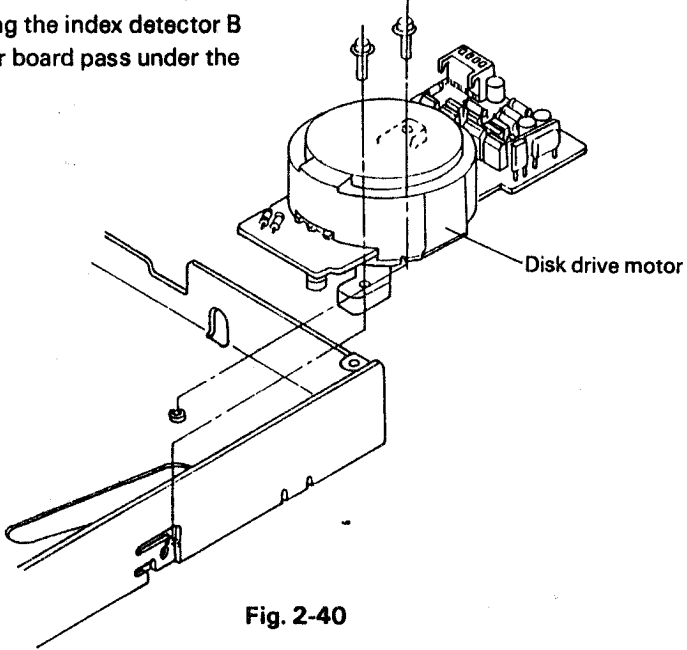
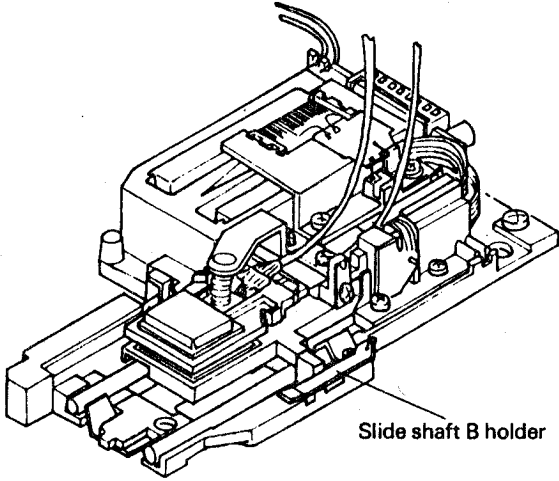

## 2.5.6 Disk drive motor and endless belt

Disassembly procedure	Notes on disassembly
<p>1) Remove the main board set. (Refer to 2.5.1)</p> <p>2) Remove the sub-frame unit. (Refer to 2.5.3)</p> <p>3) Remove the disk drive motor fixing screws. (Fig. 2-39)</p> <p style="padding-left: 40px;">CS M2.5 × 6 × 2</p> <p>4) Remove the slide shaft B holder fixing screw, and take off the slide shaft B holder from the VCM unit. (Fig. 2-40)</p> <p>5) Remove the endless belt. Remove the disk drive motor from the main unit.</p>	
<p>6) Route the cable connecting the index detector B and write protect detector board pass under the eject lock lever. (Fig. 2-39)</p>	<div style="text-align: center;">  <p>Fig. 2-40</p> </div> <div style="text-align: center;">  <p>Fig. 2-41</p> </div>

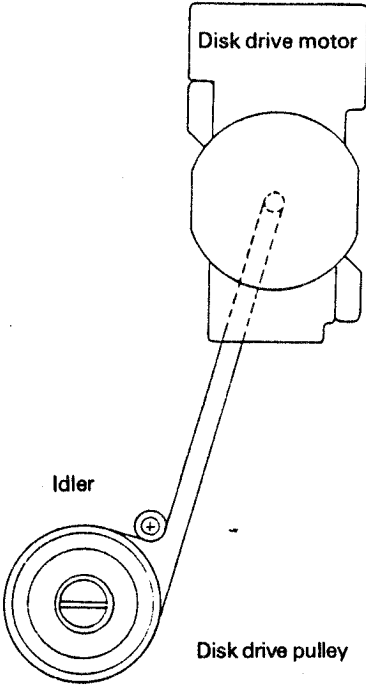
Disassembly procedure	Notes on disassembly
<ol style="list-style-type: none"> <li>1) Fix the disk motor with the disk drive motor fixing screws. (Screw tightening torque: 5.0 kg-cm)</li> <li>2) Mount the endless belt on the disk drive motor pulley, idler bearing and disk drive pulley in that order. (Fig. 2-42)</li> <li>3) Fix the slide shaft B holder to the VCM unit with the slide shaft B holder fixing screw.</li> <li>4) Mount the sub-frame. (Refer to 2.5.3)</li> <li>5) Mount the main board set. (Refer to 2.5.1)</li> <li>6) Check the disk speed. (Refer to 3.4.2)               <ul style="list-style-type: none"> <li>Note 1. Check the disk rotates smoothly without generating abnormal noise.</li> <li>Note 2 Check the belt is not frayed or cracked.</li> </ul> </li> </ol>	
	
<p><b>Fig. 2-42</b></p>	

## 2.5.7 Disk guide (R), idler set and disk drive pulley set

Disassembly procedure	Notes on disassembly
<p>1) Remove the main board set. (Refer to 2.5.1)</p> <p>2) Remove the sub-frame unit. (Refer to 2.5.3)</p> <p>3) Remove the endless belt.</p> <p>4) Remove the idler fixing screw. Remove the flat washer and idler bearing. (Fig. 2-43)</p> <p style="padding-left: 40px;">CP: M3 × 7 × 1</p> <p>5) Remove the disk guide sleeve from the disk guide (R).</p> <p>6) Remove the disk guide (R) fixing screws. (Fig. 2-44)</p> <p style="padding-left: 40px;">CS: M2.5 × 8 × 2</p> <p>7) Remove the disk drive pulley screw. Remove the disk drive pulley set.</p>	

Idler bearing

Fig. 2-43

Disk guide sleeve

Disk guide (R)

Fig. 2-44

Resassembly procedure	Notes on resassembly
<ol style="list-style-type: none"> <li>1) Make sure the flat washer has been set in the disk drive pulley shaft. Put the disk drive pulley set on the pulley shaft by mounting it downward on the shaft.</li> <li>2) Tighten the disk drive pulley and fix it with a screw. (Screw tightening torque: 5.0 kg-cm)</li> <li>3) Rotate the disk drive pulley 2 ~ 3 times to make sure it rotates smoothly without abnormal noise or unevenness.</li> <li>4) Set the disk guide (R) and disk guide pulley. Tighten the disk guide (R) fixing screws. (Screw tightening torque: 3.5 kg-cm)</li> <li>6) Mount the endless belt. (Refer to 2.5.6)</li> <li>7) Mount the sub-frame unit. (Refer to 2.5.3)</li> <li>8) Mount the main board set (Refer to 2.5.1)</li> <li>9) Check the disk speed. (Refer to 3.4.2)</li> </ol>	
 <p style="text-align: right; margin-right: 50px;">Disk drive pulley</p>	

Fig. 2-45

## 2.5.8 Index detector A set

Disassembly procedure	Notes on disassembly
<ol style="list-style-type: none"><li>1) Remove the main board set. (Refer to 2.5.1)</li><li>2) Remove the index detector A set fixing screw. (Fig. 3-23) CP: M2.5 × 4 × 1</li><li>3) Remove the sub-frame unit (Refer to 2.5.3)</li><li>4) Remove the front panel. (Refer to 2.5.4)</li><li>5) Remove the disk guide (L) unit. (Refer to 2.5.5)</li><li>6) Remove the write protect detector. (Refer to 2.5.5)</li><li>7) Desolder the cable of the index detector A set from the write protect detector board.</li></ol>	

Index detector A

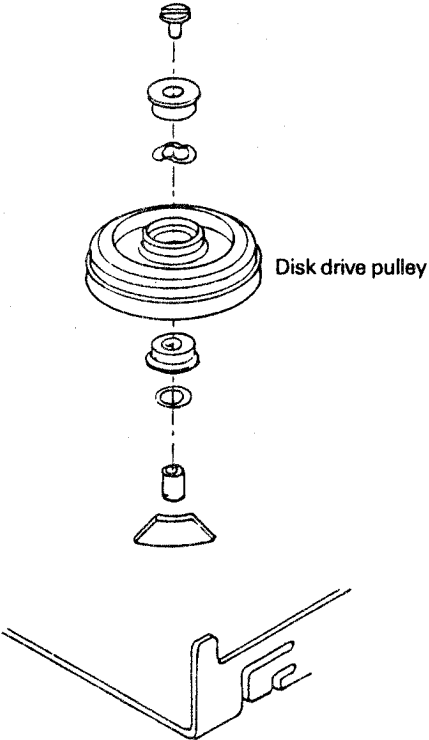
Sub-frame

**Fig. 2-46**

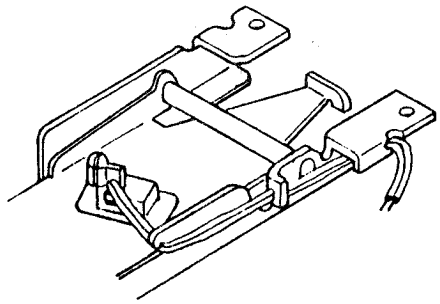
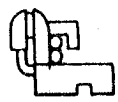
Resassembly procedure	Notes on resassembly
<ol style="list-style-type: none"> <li>1) Solder the cable of index detector A to the write protect detector board.</li> <li>2) Carry out disassembly procedure in reverse.</li> <li>3) Fix the index detector A set temporarily to the sub-frame with the index detector A set fixing screw.</li> <li>4) Route the lead wire of the index detector through the specified circuit. (Fig. 2.47)</li> <li>5) Mount the main board set. (Refer to 2.5.1)</li> <li>6) Adjust the index. (Refer to 3.4.5)</li> </ol>	<ul style="list-style-type: none"> <li>● Solder the black wire of the cable to "B".</li> </ul>
  <span style="margin-left: 20px;">← Lead wire connected</span>	
<p><b>Fig. 2-47</b></p>	

## 2.5.9 Index detector B set

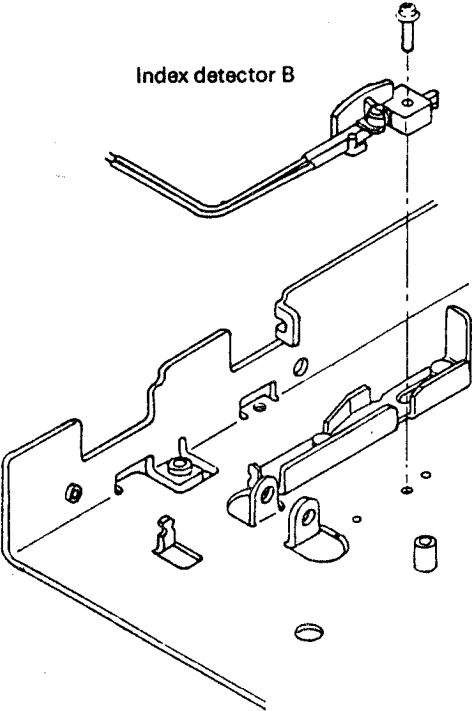
Disassembly procedure	Notes on disassembly
<ol style="list-style-type: none"><li>1) Remove the main board set. (Refer to 1.5.1)</li><li>2) Remove the sub-frame unit. (Refer to 2.5.3)</li><li>3) Remove the index detector B fixing screw (Fig. 3-25) CP: M2.5 × 8 × 1</li><li>4) Remove the front panel. (Refer to 2.5.4)</li><li>5) Remove the disk guide (L) unit. (Refer to 2.5.5)</li><li>6) Remove the write protect detector. (Refer to 2.5.5)</li><li>7) Desolder the cable of the index detector B set from the write protect detector board.</li></ol>	
 <p data-bbox="702 1666 801 1697">Fig. 2-48</p>	

Resassembly procedure	Notes on resassembly
<ol style="list-style-type: none"> <li>1) Solder the cable of index detector B to the write protect detector board.</li> <li>2) Fix the index detector B set to the main unit with the index detector B set fixing screws. (Screw tightening torque: 3.5 kg-cm)</li> <li>3) Route the lead wire of the index detector B through the specified circuit.</li> <li>4) Mount the disk guide (L) unit. (Refer to 2.5.5)</li> <li>5) Mount the front panel. (Refer to 2.5.4)</li> <li>6) Mount the sub-frame unit. (Refer to 2.5.3)</li> <li>7) Mount the main board set. (Refer to 2.5.1)</li> <li>8) Adjust the index. (Refer to 3.4.2)</li> <li>9) Eject lock lever set</li> </ol>	<ul style="list-style-type: none"> <li>● Solder the red wire of the cable to "R" and white wire to "W".</li> </ul>



### 2.5.10 Eject lock lever set

Disassembly procedure	Notes on disassembly
<ol style="list-style-type: none"> <li>1) Remove the main board set. (Refer to 2.5.1)</li> <li>2) Remove the sub-frame unit. (Refer to 2.5.3)</li> <li>3) Remove the front panel. (Refer to 2.5.4)</li> <li>4) Remove the disk guide (L) unit. (Refer to 2.5.5)</li> <li>5) Remove the ejector spring.</li> <li>6) Loosen and remove the E stopper ring of the disk drive pulley side of the eject lock lever. RE: ETWJ - 2.3 × 1</li> </ol>	
Resassembly procedure	Notes on resassembly
<ol style="list-style-type: none"> <li>1) Set the eject lock lever set in the main unit. Insert the eject lock lever shaft from the disk guide (L) unit and fix it with the E stopper ring.</li> <li>2) Hook the eject spring between the ejector and main unit.</li> <li>3) Mount the disk guide (L) unit (Refer to 2.5.5)</li> <li>4) Mount the front panel (Refer to 2.5.4)</li> <li>5) Mount the sub-frame unit. (Refer to 2.5.3)</li> <li>6) Mount the main board set. (Refer to 2.5.1)</li> </ol>	<ul style="list-style-type: none"> <li>● Check the eject lock lever spring is attached to the eject lock lever set.</li> </ul>