

Chapter 1

GETTING ACQUAINTED

1.1 Elements of the PX-4 System

1.1.1 Unpacking

Open the carton and remove the PX-4 computer and all its accessories.

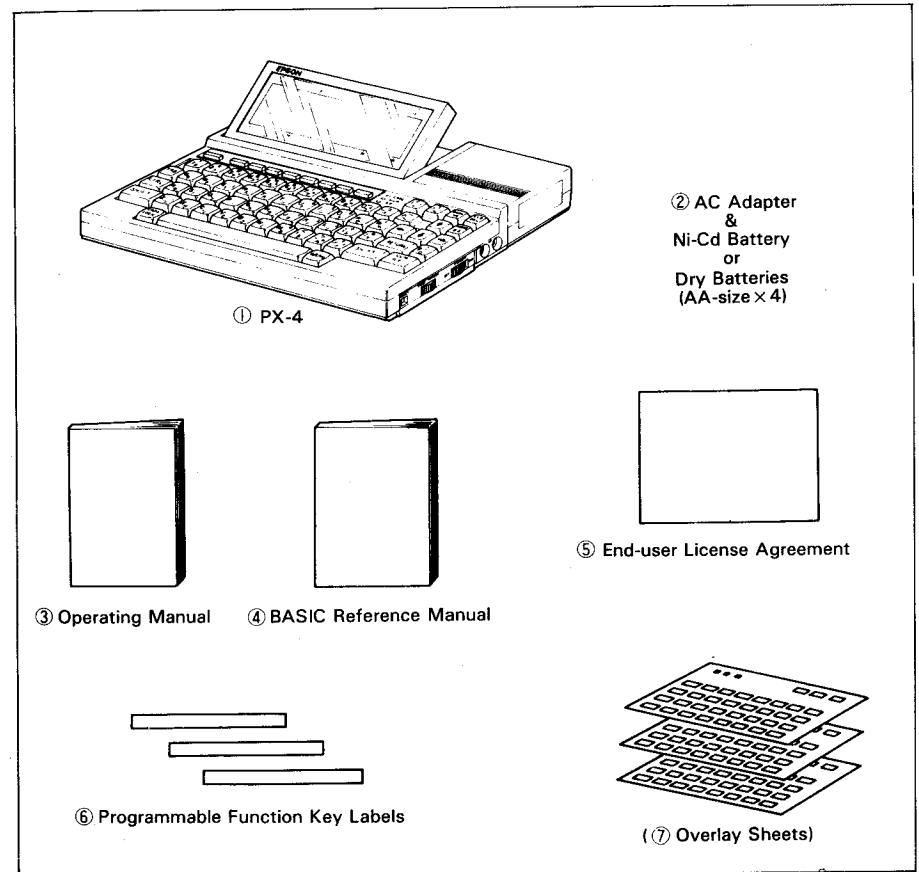

1.1.2 Appearance

PX-4 is a high performance hand-held computer which combines a keyboard, a liquid crystal display screen, and a variety of interfaces all in one package. Its compact size and light weight makes it easy to carry and use practically anywhere.

Before starting to use the computer, take a moment to become familiar with its appearance and the names of its various parts.

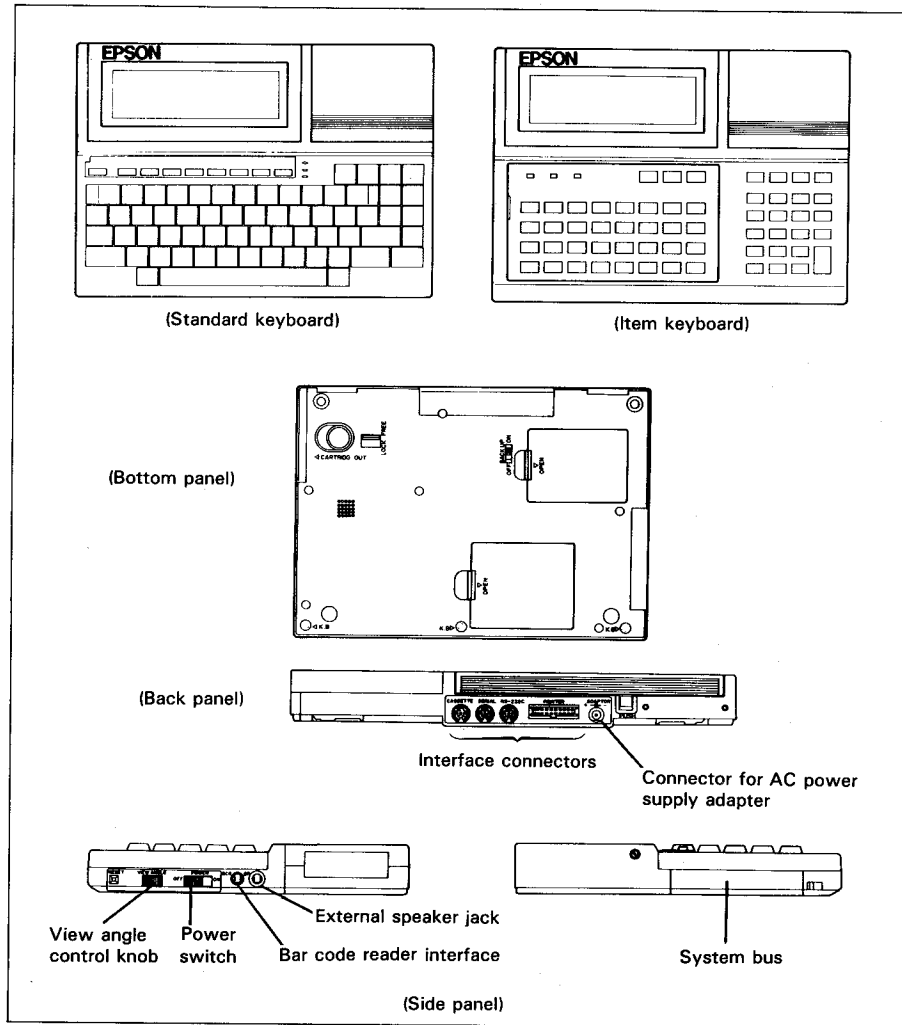

LCD Release Button

The LCD screen can be tilted forward by lifting the screen at the top while pressing this button. When returning the screen to its storage position (tilted back), push it back until the screen latch clicks into place.

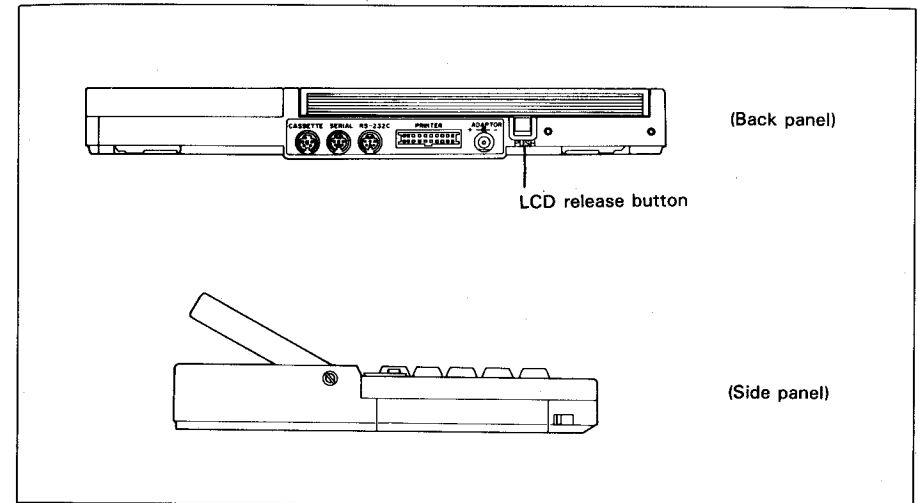

View Angle Control Knob

Turning this knob changes the apparent display contrast.

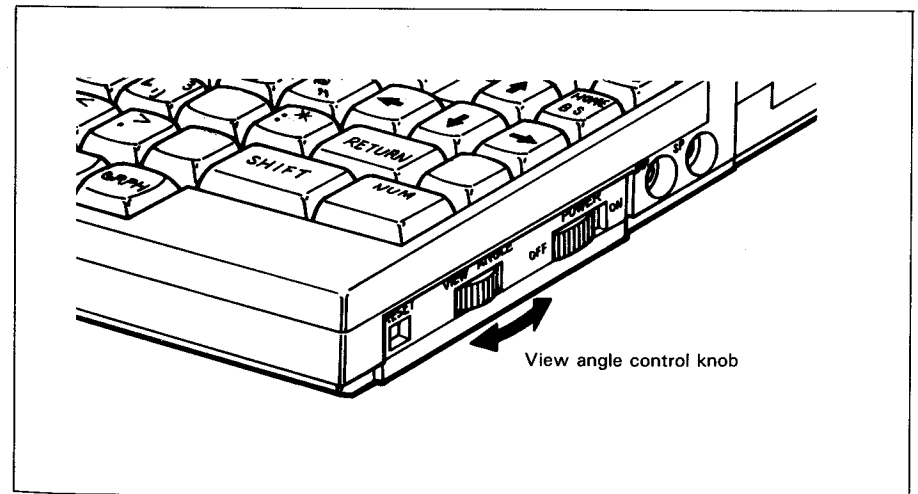

Legs

Two folding legs are built into PX-4's back panel. Extend these legs when you want increase the angle of keyboard inclination.

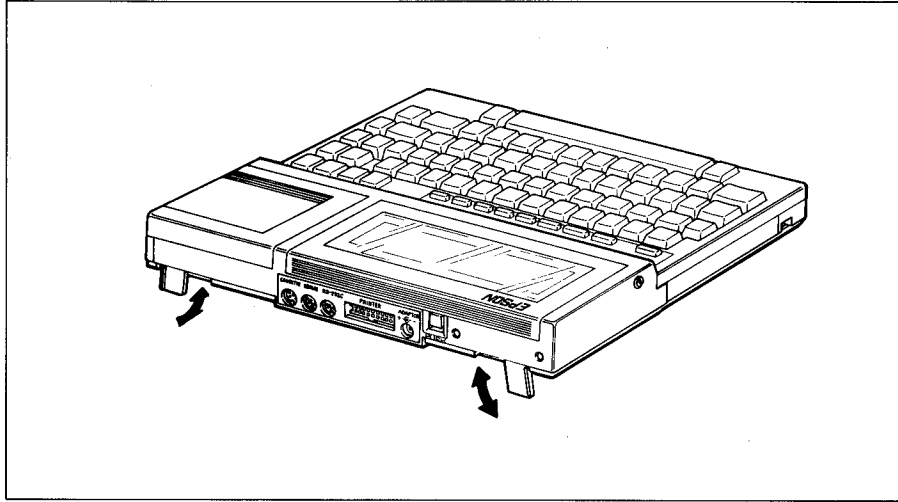

Connector for AC Power Supply Adapter

When using the AC power supply adapter, connect it to PX-4 as shown in the figure below.

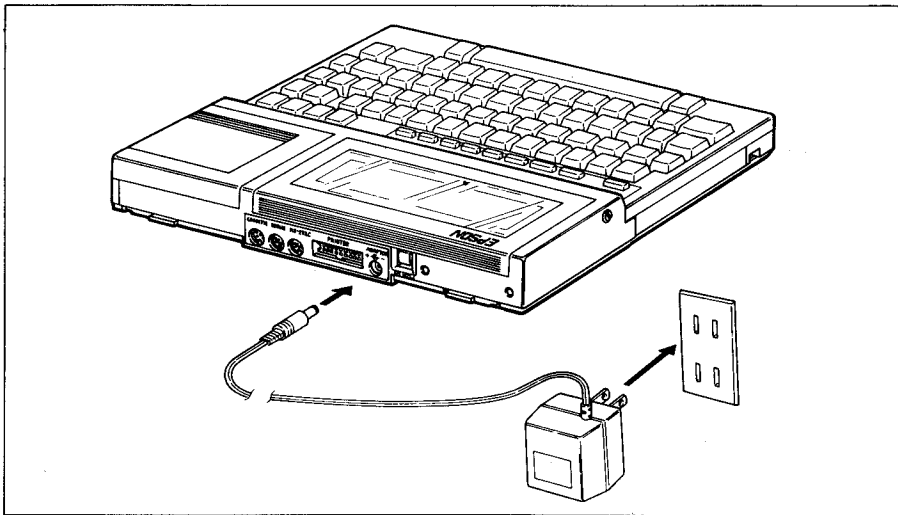

Battery Compartment

The battery compartment houses PX-4's main batteries (dry cells or NiCd battery pack).

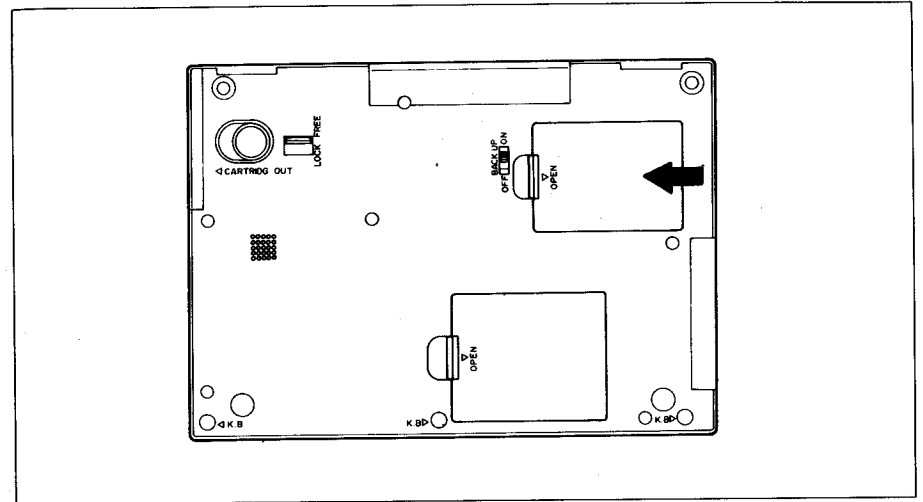

ROM Capsule Compartment

ROM capsules are installed in the ROM capsule compartment.

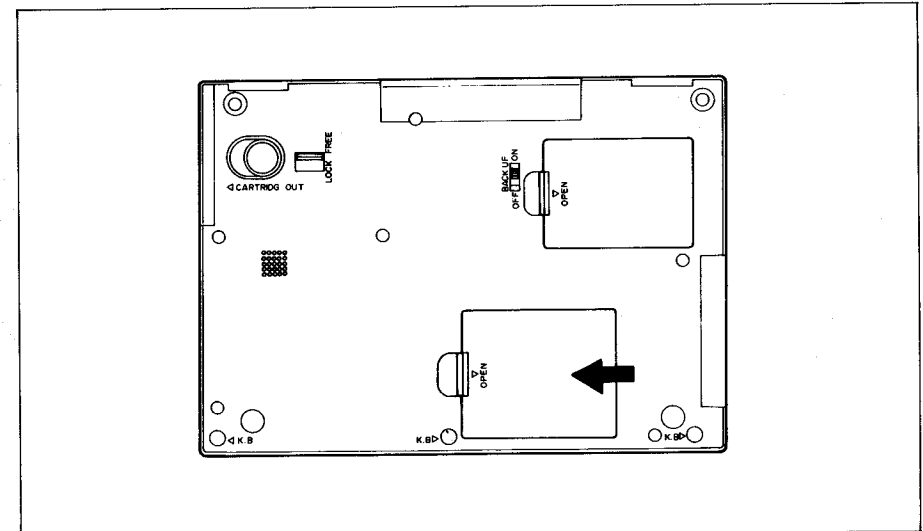

Reset Switch

The reset switch is not used during normal operation. However, it is used to reset the system when operation hangs up (stops due to an error which cannot be corrected by any other means). Use a ball point pen or the like to press this switch.

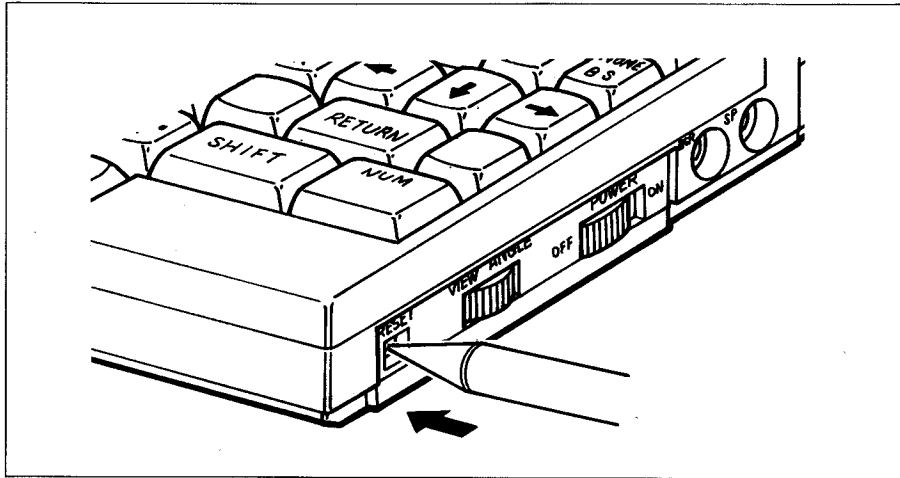

Power Switch

This switch is used to turn PX-4 on and off.

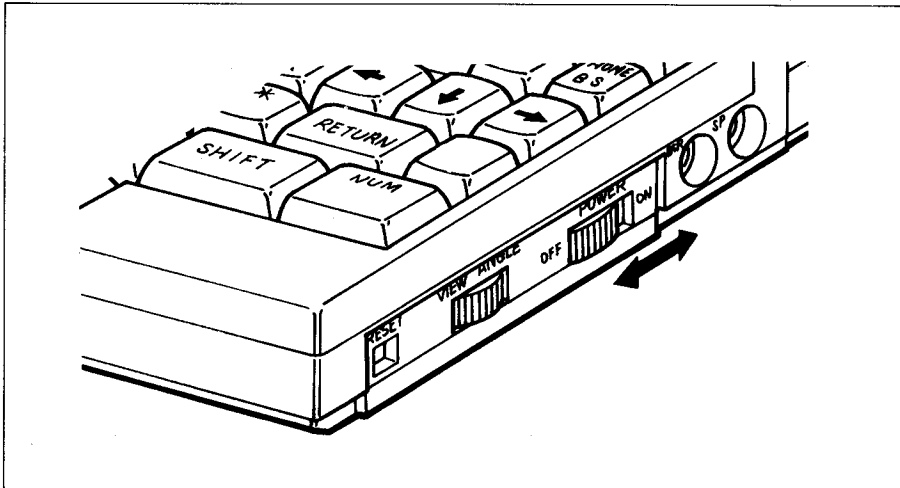

Interface Connectors

There are four interface connectors on the back panel. The names of these connectors are as shown in the figure below.

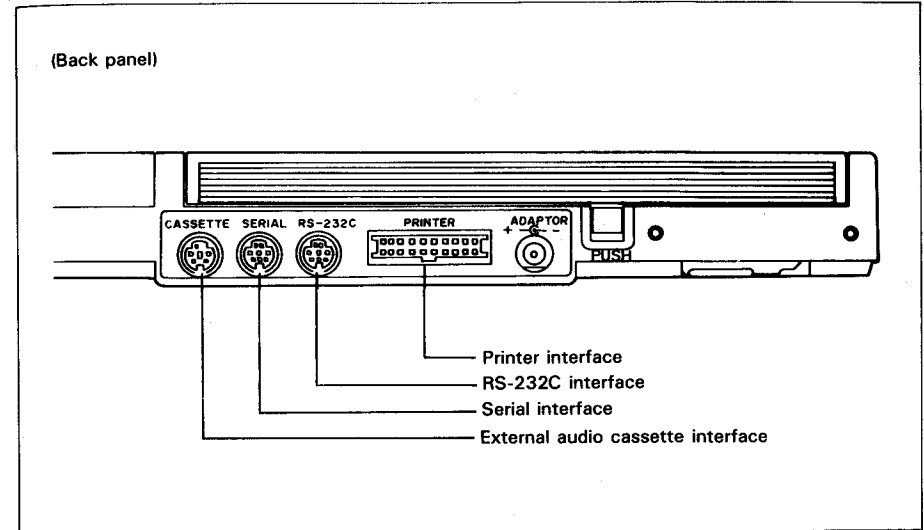

There are two interface connectors on the side panel as shown in the figure below.

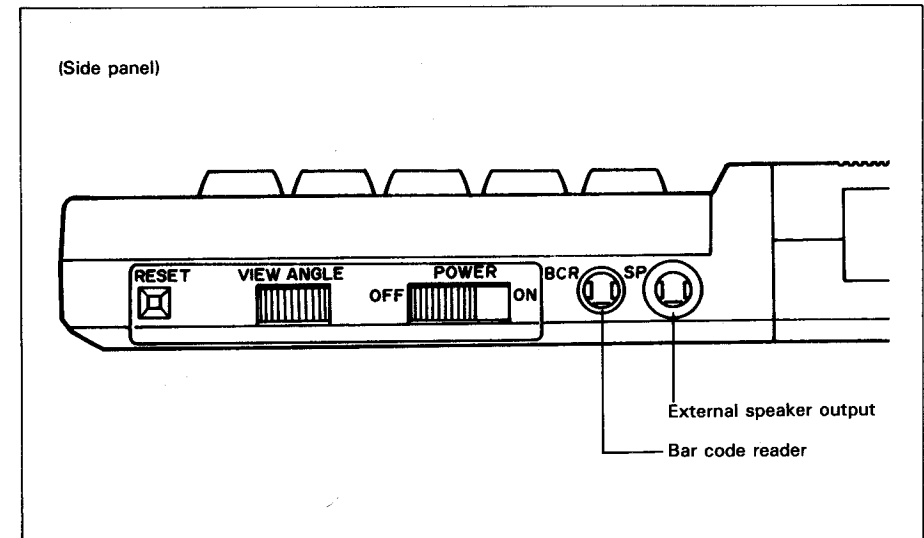

1.1.3 System configuration

The configuration of PX-4 is shown in the figure below.

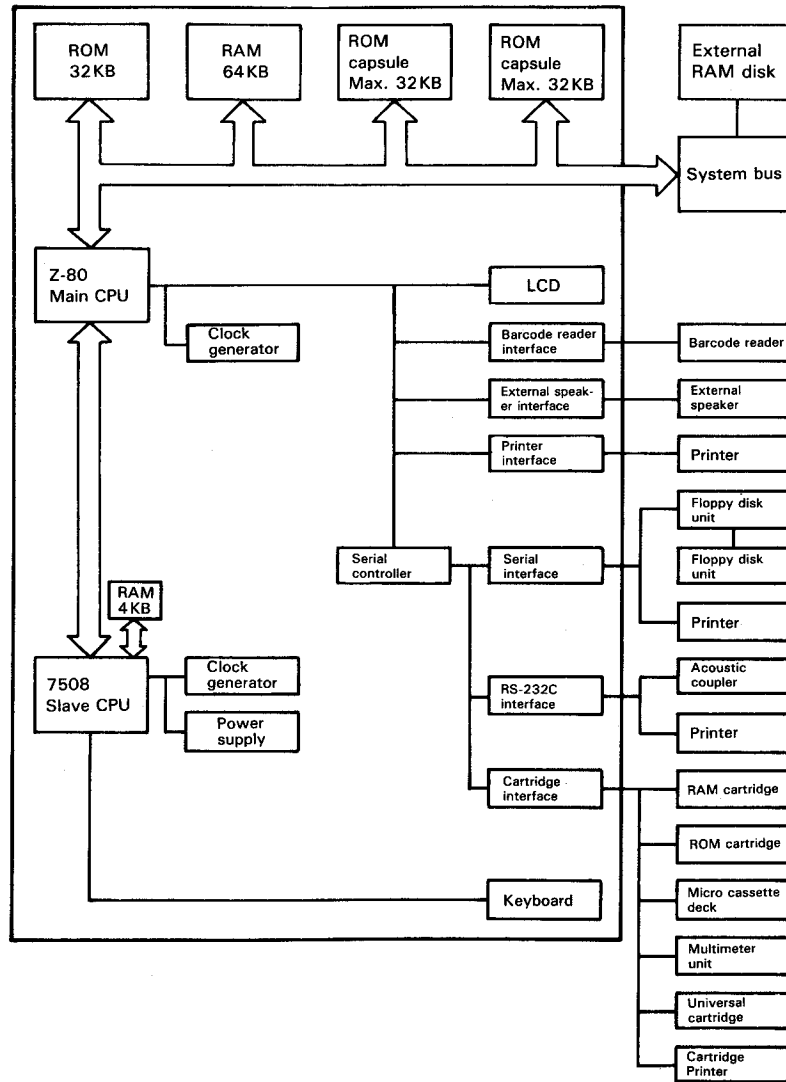

The figure below shows a representative configuration of the PX-4 system.

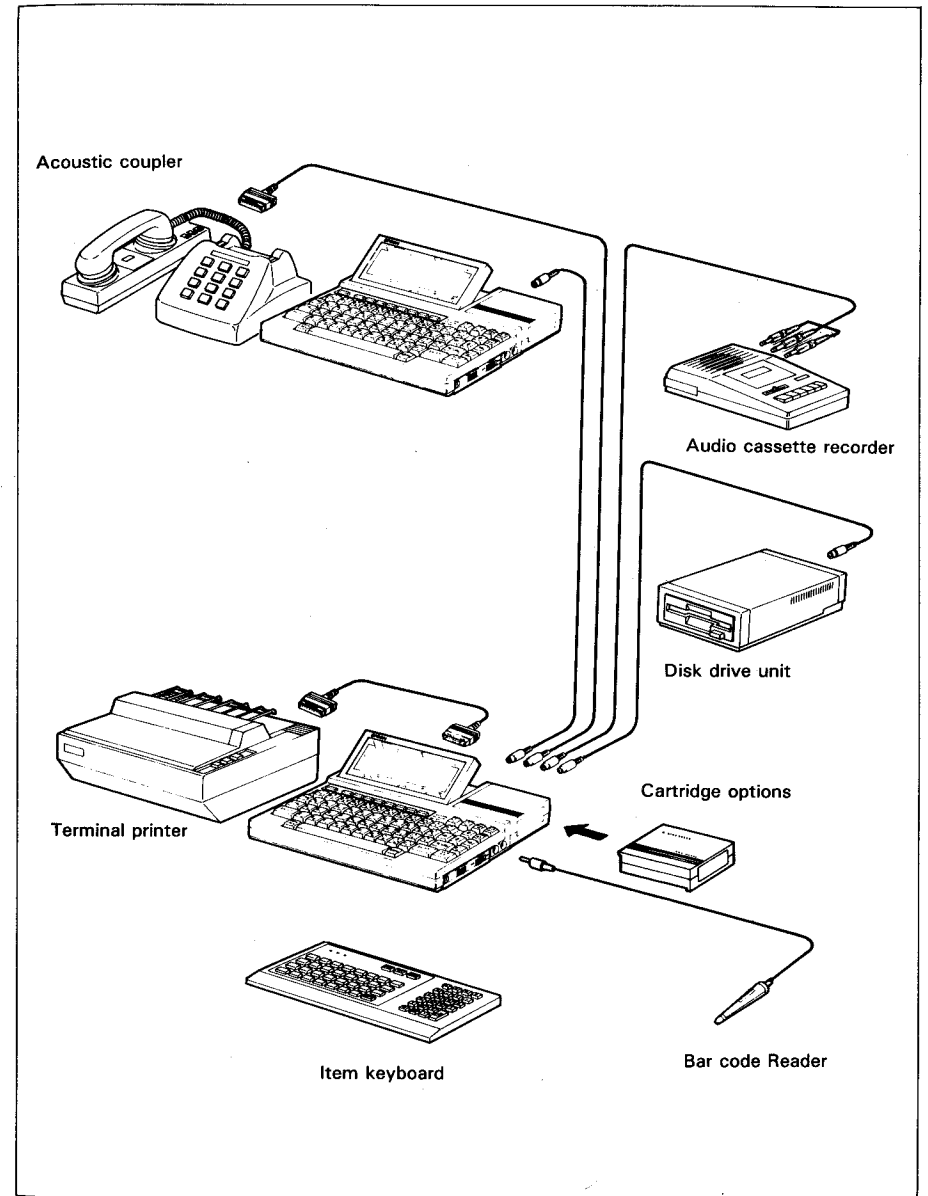

1.2 Hardware

The hardware of PX-4 consists of the following basic components.

Power supply
CPU and memory
Keyboard (Standard Keyboard or Item Keyboard)
LCD screen
RAM disk
ROM capsules

This section briefly explains these hardware components; for detailed specifications, see Appendix A, "Hardware Specifications." (For information on interfaces, see Chapter 3 "Standard Input/Output Interfaces"; for information on optional devices such as printers and floppy disk drives, see Chapter 4 "Optional Devices.")

Basic Hardware Configuration of PX-4

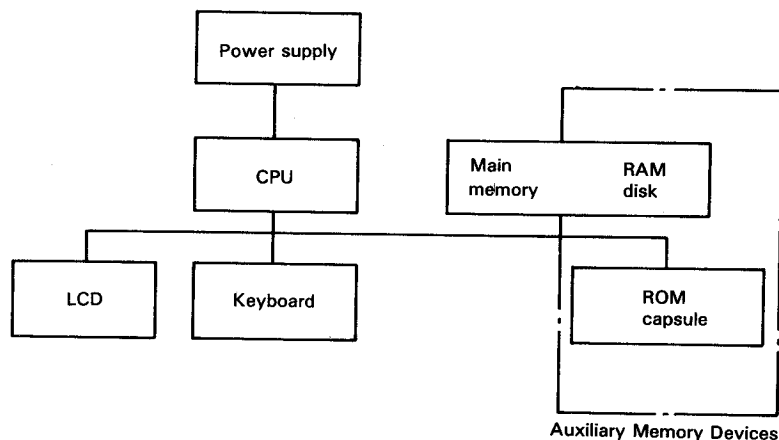

1.2.1 Power supply

PX-4 is equipped with two power supplies: a main supply (4.8V) and a sub battery (4.8V). Any of the following three units can be used as the main power supply.

- Dry cells (four AA batteries)
- NiCd battery pack
- AC power adapter

A NiCd battery pack and AC power adapter are supplied with PX-4 as standard accessories; dry cells must be purchased separately.

If the main power supply voltage drops below a certain level, the message

CHARGE BATTERY

is displayed to indicate that the batteries require charging or replacement. This condition is referred to as a power failure.

If this message is displayed while the NiCd battery pack is installed, connect the AC power adapter; if dry cells are being used, replace them.

See section 2.1, "Introduction to Operation" or section 2.9, "Battery Charging and Replacement" for battery charging and replacement procedures.

The sub battery provides the backup power supply for PX-4's main and slave CPUs. Power for memory backup is drawn from this battery only when a main battery power failure occurs. Since the contents of memory will be lost if the sub battery becomes discharged, be sure to replace or recharge the main batteries promptly.

The sub battery is rechargeable and can be used almost indefinitely; therefore, it ordinarily will not require replacement. The sub battery is recharged on power drawn from the main battery while PX-4 is turned on; if PX-4 is turned off, it is recharged only if the AC power adapter is connected.

1.2.2 CPU and memory

Two CPUs are used in PX-4: a Z-80 8-bit main CPU and a 7508 4-bit slave CPU. The slave CPU controls the keyboard and functions such as power supply.

Main memory assigned to the main CPU includes 32K bytes of ROM (read only memory), 64K bytes of RAM (random access memory), and up to 64K bytes of optional ROM in the form of ROM capsules (up to two 32K-byte ROM capsules).

However, since the CPU can only address 64K bytes of memory at one time (the addresses from 0 to 65535), the memory is divided up into banks as shown in the figure below and the CPU switches itself between banks to allow all of memory to be accessed.

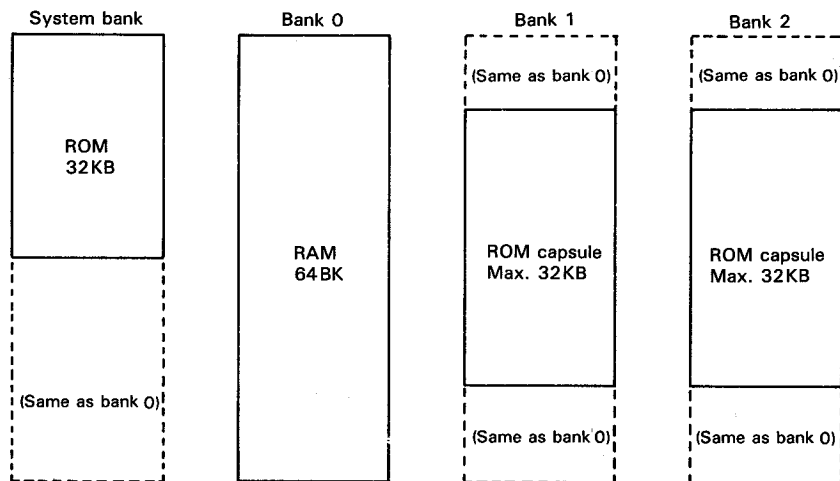

The system bank ROM contains the CP/M operating system and basic system programs. The RAM in bank 0 is used as work area and user area. The ROM in banks 1 and 2 contains utility programs. (In the standard PX-4, bank 1 holds the ROM which contains BASIC and bank 2 is empty.)

NOTE:

Utility ROM capsule can be installed into bank 2.

In addition to the above, 4K bytes of ROM are assigned to the slave CPU. This memory contains the software which controls slave CPU operation. The slave CPU operates constantly, regardless of the setting of the power switch.

1.2.3 RAM disk

With PX-4, part of main memory can be used for storage of files in the same manner as an external disk drive. Use of main memory for file storage makes it possible to access (retrieve or store) files much faster than is possible with conventional floppy disk devices. To increase work efficiency, use of the RAM disk is recommended for programs which use frequent disk access or which require random access to disk.

The contents of the RAM disk are managed using a directory in the same manner as with conventional floppy disks. The directory information is stored in the RAM disk, and contains information which is used to manage files. A maximum of 16 files can be stored in the RAM disk at one time.

Unless otherwise specified by the user, the size of the RAM disk is 26K bytes. However, the size can be changed in 1K byte increments to anywhere in the range from 2K bytes to 35K bytes. It is also possible to delete the RAM disk entirely by specifying its size as 0 bytes. The RAM disk size is specified during system initialization or using the CONFIG command which is included in the optional utility ROM.

Data stored in the RAM disk is maintained even when the power switch is turned off (this is referred to as "memory backup").

An optional 16KB RAM cartridge can be installed for use as an additional RAM disk. (See Chapter 4 "Optional Devices" for more information on the RAM cartridge and conventional floppy disk drives.)

Further, RAM disk capacity can be expanded to 128KB by installing an optional 128KB external RAM disk unit. In this case, RAM disk capacity (drive A) is fixed to 128K bytes.

1.2.4 Keyboard

One of the most prominent features of PX-4 is its keyboard, which can be easily removed and replaced with one of another type. Types of keyboards which can be used with PX-4 are the standard keyboard and the item keyboard. Several different versions of the standard keyboard are provided for different countries (the U.S., England, France, Germany, Denmark, Sweden, Norway, Italy and Spain). See section 4.2 "Keyboards" for keyboard replacement procedures.

The keyboard is controlled by the 7508 slave CPU. This releases the main CPU from the need to do keyboard processing and thus increases the speed with which other processing is performed.

PX-4's keyboard is equipped with a feature called the auto repeat function. This function makes it possible to enter the same character repeatedly simply by pressing and holding the corresponding key. When the item keyboard is installed, the auto repeat function is turned off until it is turned on by the user.

Standard Keyboard

PX-4's standard keyboard includes 72 keys which are grouped by function in a compact arrangement as shown in the figure below. Character keys are arranged in the standard typewriter keyboard layout. The key tops are sculptured, providing more positive "feel" for touch typing. Character sets supported include ASCII, English, French, and German Denmark, Sweden, Norway, Italy and Spain; depending on the system, the user can select from among these character sets.

See section 2.3 "Inputting Data from the Keyboard" concerning the types of keys and their uses.

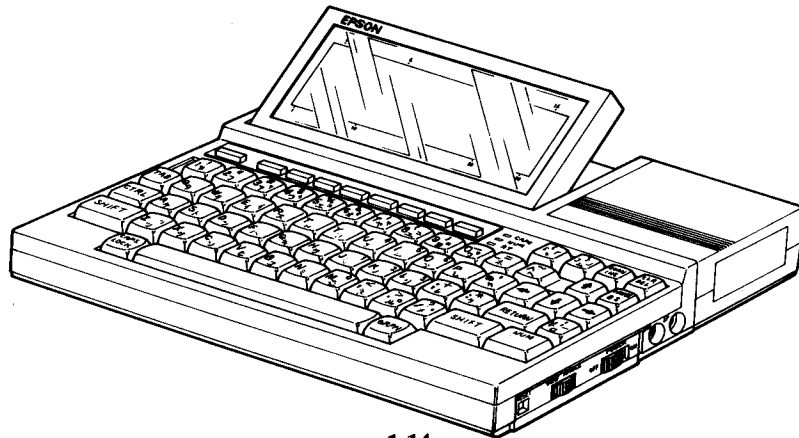

Item Keyboard

The item keyboard which can be installed on PX-4 is designed to make it easy to use PX-4 as a special purpose machine. Keys on the item keyboard are divided into two groups: the item key group and the numeric key group. The functions of all keys in the item key group can be defined by the user.

The item key group consists of 32 keys. The user can define 31 of these keys (keys other than the **SHIFT** key) so that different strings of characters are input when keys are pressed. When using the item keyboard, write the key definitions on an overlay sheet and place it and a transparent overlay over the keyboard.

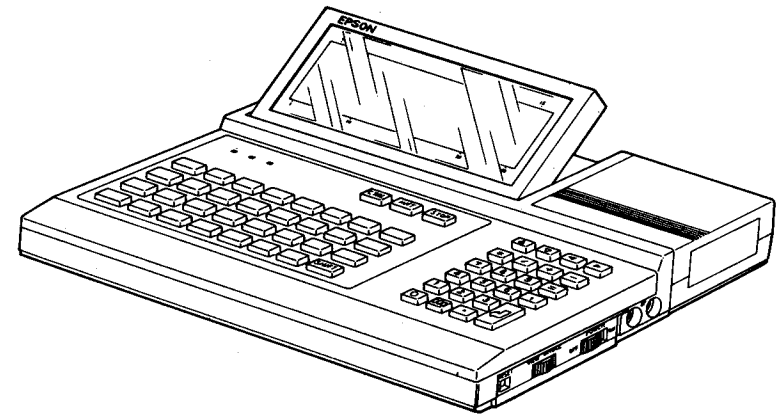

Keys on the standard keyboard can also be defined for use as item keys. See Appendix E "Programmable Function Keys and Item Keys" and the explanation of the KEY command in the BASIC Reference Manual for procedures for doing this.

1.2.5 Liquid crystal display

PX-4's LCD screen can display up to 8 40-character lines or up to 240 × 64 dots of graphics. For applications which require larger display capacities, the concept of a virtual screen has been introduced to increase the effective screen capacity to up to 25 80-character lines. See section 2.5 "Virtual Screen and Window Screen" for an explanation of the virtual screen.

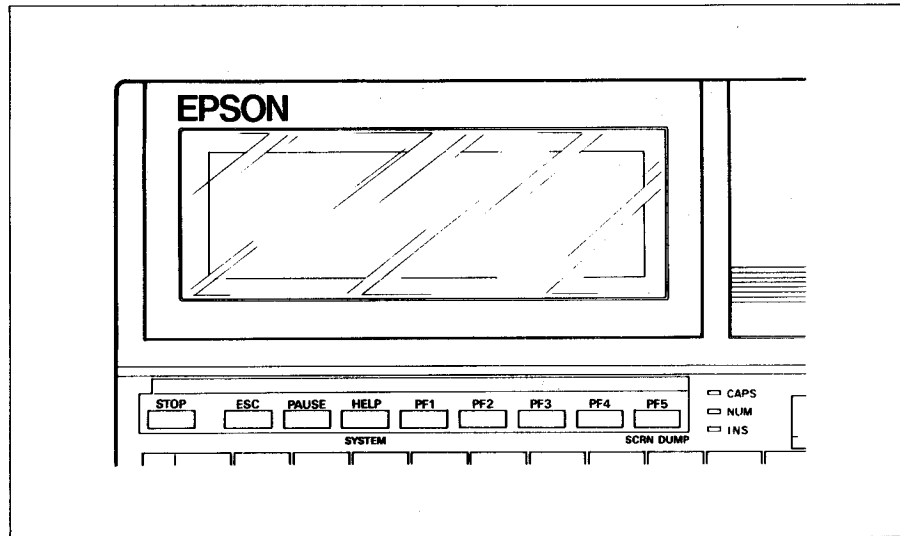

1.2.6 ROM capsules

ROM capsules in the ROM capsule compartment in the bottom of PX-4 can be used as an auxiliary storage device in much the same manner as the RAM disk.

Unlike the RAM disk, a ROM capsule provides read-only storage; in other words, data or files can be read from the ROM capsule, but cannot be written to it. Application programs such as BASIC are provided in the form of ROM capsules.

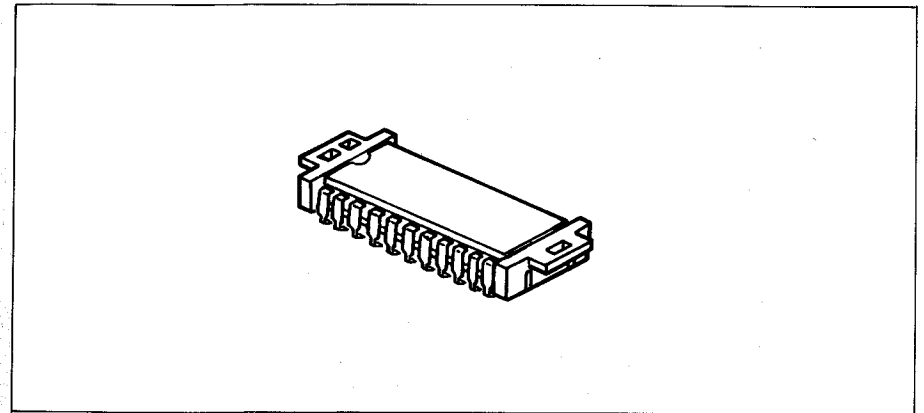

Drive names are assigned to ROM capsules in the same manner as with floppy disk drives and the system handles ROM capsules as if they were disks.

<ROM formats>

Two different types of ROM formats may be used with PX-4. With one format, programs in ROM are executed directly (without being loaded into main memory); with the other, programs are loaded into main memory for execution. With the former format, ROMs must be installed in a ROM capsule for use; with the latter, ROMs may be installed either in a ROM capsule or in a ROM cartridge.

BASIC is provided in directly executable format, while programs in optional utility software ROMs are loaded into memory for execution. (The utility ROM contains transient commands and applications.)

1.3 Software

1.3.1 Operating system (enhanced CP/M Version 2.2)

The operating system used with PX-4 is an enhanced version of CP/M Version 2.2. The operating system is software which intermediates between the hardware of a computer and application programs, and which unifies the computer system and performs overall control.

The operating system performs all processing required for file management and input/output access to peripheral devices, making it unnecessary for the user to be concerned with the details of such operations when developing application programs.

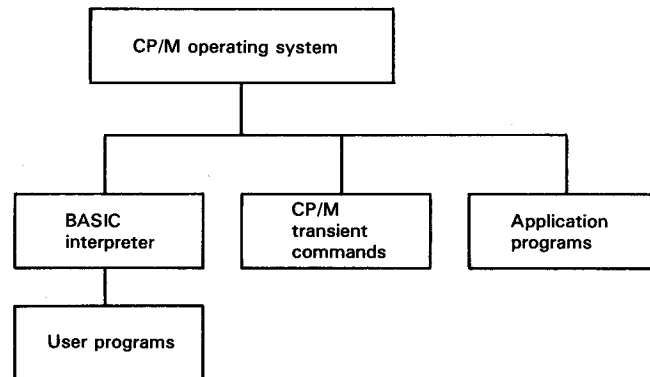

Standard CP/M is designed as a floppy disk operating system and does not support ROM capsules, RAM disk, or a microcassette drive. Therefore, CP/M used with PX-4 has been enhanced to provide support for these devices.

Further, standard CP/M is distributed on floppy disks, but CP/M for PX-4 is provided in ROM as part of main memory. Therefore, it is not possible to modify the contents of PX-4 CP/M.

<What is CP/M?>

The term CP/M stands for "control program for microprocessors," and refers to a floppy disk operating system (FDOS) which was developed by Digital Research, an American corporation, for 8-bit microcomputers. The CP/M operating system cannot be used with all 8-bit microcomputers, but only those which are based on the 8080, 8085, or Z-80 series of CPUs. (The CPU used in PX-4 is a Z-80.)

Currently, CP/M is widely accepted as the standard operating system for 8-bit microcomputers, and is used in many personal computers. Use of a standard operating system greatly increases the variety of application programs which can be used with a machine.

Some of the commands which are used under CP/M are as follows.

- DIR**..... Displays the contents of the file directory.
- ERA**..... Used to erase disk files.
- REN**..... Used to rename disk files.
- TYPE**..... Used to display the contents of disk files.
- SAVE**..... Used to save the contents of memory to a disk file.
- USER**..... Used to select a user area.

For example, the directory for files in drive A: can be displayed by entering the DIR command as follows.

DIR A:

The following is an example of use of the REN command to change the name of file OLD.BAS in drive A: to NEW.BAS.

REN A:NEW.BAS = OLD.BAS

Drive names and file names must be specified in the above manner with most CP/M commands. This part of the command is referred to as the file descriptor. This file descriptor consists of a drive name, file name, and file name extension.

X:XXXXXXXXX.XXX

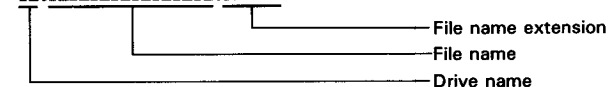

CP/M commands and file descriptors are explained in detail in section 2.7 "CP/M Commands."

When CP/M starts operating, a prompt is displayed on the screen as shown below.

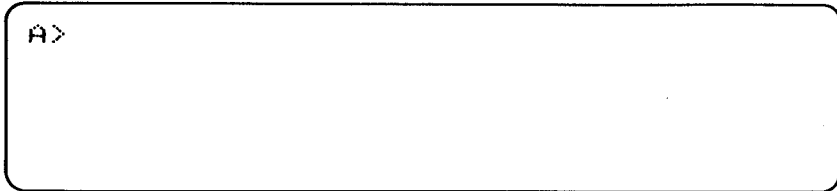

When a command is input from this screen, the corresponding program is loaded into the transient program area (TPA) in main memory from auxiliary storage and executed. All application programs which are executed under CP/M are recorded in auxiliary storage as files with the file name extension .COM. These are "program files"; i.e., machine language files which can be executed directly by the computer.

To execution an application, enter its file name, but do not type in the file name extension .COM (for example, to execute B:BASIC.COM, input B:BASIC).

When execution of the application is completed, control is returned to CCP and the screen shown above appears.

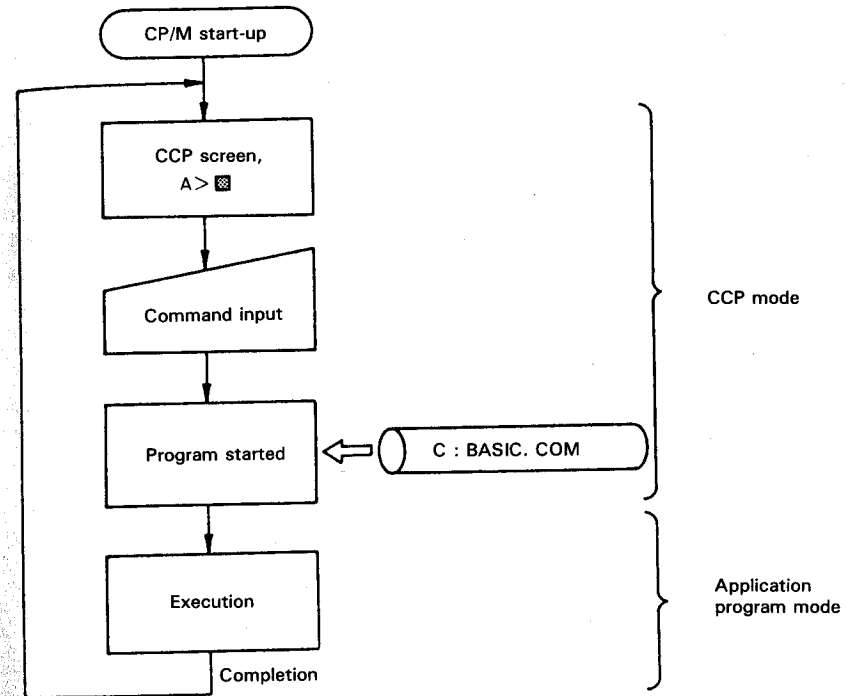

The internal structure of PX-4's operating system is shown in the figure below.

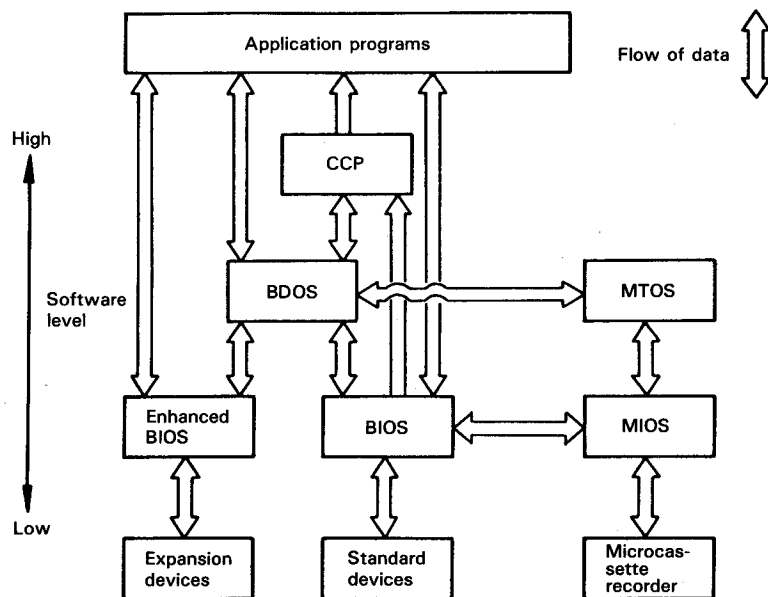

Elements at the top of this figure are at higher software levels (closer to the person using the computer) and those at the bottom are at lower software levels (closer to the machine). The elements are explained below.

CCP (console command processor)

Inputs commands from the console, loads corresponding application programs, and executes those programs.

BDOS (basic disk operating system)

Manages RAM disk and floppy disk files.

BIOS (basic input/output system)

Provides the software interface for input/output access to standard devices.

MTOS (microcassette tape operating system)

Includes the transient commands of CP/M, programs such as BASIC, and user-written programs.

Enhanced BIOS

Provides the software I/O interface between CP/M and expansion devices. System operation (see section 2.5 "System Operation") is controlled by enhanced BIOS.

Devices managed by standard BIOS include the keyboard, LCD screen, and floppy disk drives, and those managed by enhanced BIOS are the speaker, RS-232C interface, clock, serial port, ROM capsules, RAM disk, ROM cartridges, RAM cartridges, microcassette drive, and cartridge printer.

Currently, CP/M is widely accepted as the standard operating system for 8-bit microcomputers, and is used in many personal computers. Use of a standard operating system greatly increases the variety of application programs which can be used with a machine.

1.3.2 BASIC

PX-4 uses Microsoft BASIC, an interpreter which is widely accepted as standard for use with microcomputers. The interpreter has been enhanced by EPSON to provide a variety of powerful new functions, including a time control function and a communication function. Other features which have been added to provide greatly increased operability are as follows.

- Division of the BASIC program area into five segments, allowing up to five BASIC programs to be present in memory at the same time.
- Addition of an edit mode which can be used together with the screen editor to increase the speed and efficiency with which programs can be modified.

For details on BASIC, see the BASIC Reference Manual.

NOTE:

BASIC can only be used when installed in a ROM capsule; it cannot be used in ROM cartridge form.

1.3.3 Utility ROM (optional)

The utility ROM contains transient CP/M commands such as PIP and STAT and application programs such as CONFIG, TERM, and FILINK. The CONFIG program is used to set a variety of PX-4 operating parameters, and programs such as TERM and FILINK make it possible to use PX-4 as a terminal with a host computer or to transfer programs between PX-4 and another computer. See Chapter 5 for detailed explanations of these programs and procedures for using them. The utility ROM can be used either in a ROM capsule or a ROM cartridge.